

We are IntechOpen, the world's leading publisher of Open Access books Built by scientists, for scientists

5,800

Open access books available

142,000

International authors and editors

180M

Downloads

Our authors are among the

154

Countries delivered to

TOP 1%

most cited scientists

12.2%

Contributors from top 500 universities



WEB OF SCIENCE™

Selection of our books indexed in the Book Citation Index
in Web of Science™ Core Collection (BKCI)

Interested in publishing with us?
Contact book.department@intechopen.com

Numbers displayed above are based on latest data collected.
For more information visit www.intechopen.com



Criteria for Improving the Embankment-Structure Transition Design in Railway Lines

Inmculada Gallego, Santos Sánchez-Cambronero and Ana Rivas
University of Castilla-La Mancha
Spain

1. Introduction

In the design of a railroad track there are some situations in which the introduction of a structure in the track is needed, for example a bridge, a viaduct or a pontoon. This circumstance is even more frequent in the High Speed lines, since the design criteria, fundamentally slopes and radius, are stricter than those for conventional lines. The introduction of a structure determines the appearance of a point with an abrupt change in the vertical stiffness from a track cross section to another.

The experience has shown that these transition zones between embankment and structure are the source of many problems (related to safety, passengers' comfort, maintenance expenses, etc.), causing differential settlements among adjacent track cross sections and originating which is known as "dip" (European Rail Research Institute, ERRI., 1999)

In order to diminish this unfavorable effect, the well known "technical blocks" are designed in a length determined between the structure and the embankment of access to this one. However, in spite of this structural disposition, it has not been found yet any design solution that notably reduces the track geometrical quality defects that have been observed in the mentioned zones. This is an important issue, because they produce a relevant increase in the maintenance expenses of the High Speed lines and they affect the availability of the track (Gallego, López, Ubalde, & Texeira, 2005).

2. Theoretical foundation of embankment-structure transition behavior

The wheel load transmitted by a train to the track does not correspond to the static load; instead, random dynamic overloads appear due to the sprung and un-sprung masses. Among the great amount of existing formulations relative to these overloads, there is an outstanding contribution made by Prud'Homme (Prud'Homme, 1970) according to the expression (1)

$$\sigma(\Delta Q_{NS}) = 0.45 \frac{V}{100} b \sqrt{mK\varphi(\varepsilon)}, \quad (1)$$

where: $\sigma(\Delta Q_{NS})$ is the standard deviation of the dynamic overloads due to the un-sprung masses of the material; V is the running speed of the vehicle; b is a variable related to the track defects and to the vehicle defects; m is the un-sprung mass of the vehicle; k is the vertical track stiffness; $\varphi(\varepsilon)$ is Damping of the track.

Expression (1) introduces a new criterion to reduce the mutual aggressiveness between track and vehicle. From that it is deduced the importance of having a low value of the vertical stiffness of the track (K) and of the un-sprung mass of the vehicle (m) to avoid increasing the dynamic overloads due to the un-sprung masses. This influence is a more relevant fact in high speed trains.

In addition, it is not only the stiffness value which determines the dynamic overloads. They are also influenced by the variation of the stiffness value that might exist from one sleeper to another.

The first studies carried out to deal with this problem were carried out by Amielin, 1974, later on in the eighties they stand out those by Lopez, 1983, Hettle, 1986, Hunt, 1997, Esveld, 2001, López A. , 2001 or Teixeira, 2003 shown that as the difference between the stiffness values of two consecutive sleepers increases, the reaction on the sleepers increases, thereby increasing the load on the sleeper. On the other hand, next to these increments of stress, the experience has proved that some differential settlements are originated. As a result of these two factors hanging sleepers can be developed that in turn increase the stress on the ballast. In order to avoid this deterioration experimented in the transitions, these sections are built the well known "technical blocks", whose aim is achieving a gradual increase in the stiffness from one sleeper to the following one, as we reach the structure.

Now, it is interesting to know: How are these designs? What criteria are used to define them? To answer these questions a revision of the designs used by the different European Railway Administrations has been made. Five types of the most used measures have been identified. They are enumerated next, being the first one the most frequently employed:

- Backfill behind the abutment either with materials of a high compression level or granular material treated with cement.
- Use of a transition slab built with reinforced concrete or another material.
- Introduction of horizontal layers on a track formation of different materials.
- Use of geosynthetics to achieve an abutment reinforced backfill.
- Treatment of the track bed and sub-ballast with cement.

Along with these measures, they have been also identified a variety of track formation materials behind the abutment. There are three types that stand out, just as it is schematized in Fig 1. The first two types are the more frequently used, and with regard to that work they will be called slope type PA and slope type PB.

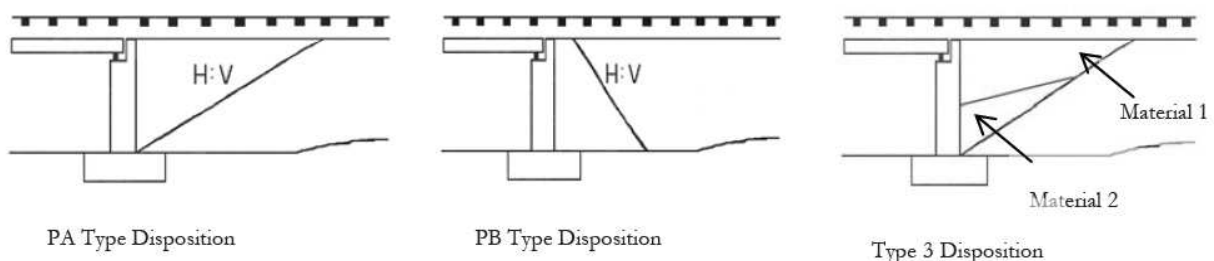

Fig. 1. Types of dispositions of the backfill behind the abutment in embankment-structure transitions.

This revision of the solutions employed, shows a lack of homogeneity of the design criteria: each Railway Administration uses different designs for the longitudinal sections of the embankment-structure transitions.

3. Motivation of the chapter

The previous analysis shows a lack of homogeneity in the design criteria. Besides, it must be added what the experience has pointed out, a remarkable deterioration of the quality in the transitions. These two facts, lead to think about two reflections: a) it does not exist a precise knowledge of the behavior of transitions, and b), the current designs have certain limitations since they are unable to reduce in a remarkable way the deterioration experimented in these areas. The first reflection invites us to deepen in the knowledge of the deterioration process and the second one induces us to consider two more aims: 1) introducing new design criteria and 2) giving an analytical basis to the already existent, to overcome some of those limitations. In order to achieve those aims a numerical modelization of the embankment-structure transition is shown in this chapter (Gallego & López, , 2009)

Therefore, within the scope of this work it is sought to carry out a model of finite elements which simulates the behavior of embankment-structures transitions. This model will enable to quantify the vertical stiffness of the track according to the type of disposition of the materials which the transition is carried out with (PA and PB, Fig 1) as well as the geotechnical characteristics of these materials (See Tab 1 and Tab 2).

Material	E (N/m ²)	ν	c (N/m ²)	ϕ (°)	ρ (N/m ³)
Rail steel	2.1x10 ¹¹	0.3	-	-	7.5 10 ⁴
Elastic bearing	2.952x10 ⁸	-	-	-	-
Sleeper element 1	8.01x10 ¹⁰	0.25	-	-	-
Sleeper element 2	5.02x10 ¹⁰	0.25	-	-	-
Sleeper element 3	3.68x10 ¹⁰	0.25	-	-	-
Ballast	1.3x10 ⁸	0.2	0	45	1.9x10 ⁴
Sub-ballast	1.2x10 ⁸	0.3	0	45	1.9x10 ⁴
Track bed	8.10 ⁷	0.3	0	35	2x10 ⁴
Material QS1	1.25x10 ⁷	0.4	15000	10	2x10 ⁴
Material QS2	2.50x10 ⁷	0.3	10000	20	2x10 ⁴
Material QS3	8x10 ⁷	0.3	0	35	2x10 ⁴
Cement-treated granular material	1.6x10 ⁸	0.25			2.3x10 ⁴
Rock	3x10 ⁹	0.2			2.7x10 ⁴

Table 1. Values of geotechnical parameters considered in the models

GEOMETRIC PARAMETERS		GEOTECHNICAL PARAMETERS		Name of case studies H embankment (H7)- Disposition - value of the slope- material 1- material2-original ground
Type of design (Fig 1)	Slope value (H:V)	Type material of transition (type1/type2)	Original ground	
PA	1:1	QS2/QS3	QS1	H7PA11QS2QS3QS1
PB	3:1	QS2/MGT* QS3/MGT*	QS2 QS3 ROCA	

*MGT = Cement-treated granular material

Table 2. Geometric and geotechnical parameter considered in the model

4. Description of the numerical model and the work assumptions

In order to quantify the vertical track stiffness value and the incidence that the disposition and type of material of the track formation have on it, it is considered more accurate to analyze the track as a whole system. So as to carry out this analysis, the most appropriate approach is to apply the finite elements method. This method enables the numerical simulation of different materials and diverse boundary conditions, facilitating the study of the interaction among the different elements that compose the railway superstructure and infrastructure.

The employment of the finite elements method is accurate to evaluate the global behavior of the track structure, but it is very limited to quantify the efforts in the ballast: the inter-granular stress is very different from stress and strain assumed in a continuous medium. However, the use of a discrete elements model, or a mixed one, finite and discrete elements, implies a tremendous computational cost and an enormous complexity.

In the Railway field, the finite elements method has been used by authors as López A. , 1977, Sauvage & Larible, 1982, Profillidis, 1983, Sahu, Rao, & Yudhbir., 1999 Mira, Fernández, Pastor, Nasarre, & Carrillo, 2000, among others. Some studies developed in the eighties stand out, such as Profillidis, 1983, since the results of those works were integrated by the Committee D-117 of the ORE in the Record (Comité D-117 (ORE), 1983). The sizing graphics of the track bearing structure are collected in this work. Together with the previous works, it is also worth mentioning those carried out by the "Ministerio de Fomento Español", which have been the basis for making some recommendations for the Railways track construction.

In order to generate the model proposed in this chapter, the contributions collected in the different models of Railways track formations carried out so far and enunciated previously have been taken into consideration.

4.1 Description of the analyzed domain

The length of an embankment-structure transition depends on the type of structure and the height of the access embankment. In the case of embankment heights around 15 meters, the technical block can reach lengths of up to 85 meters (Fig 2). A 3D Model for such that length require an extremely powerful software and hardware, implying a huge computational cost due to the long time calculation that would be needed.

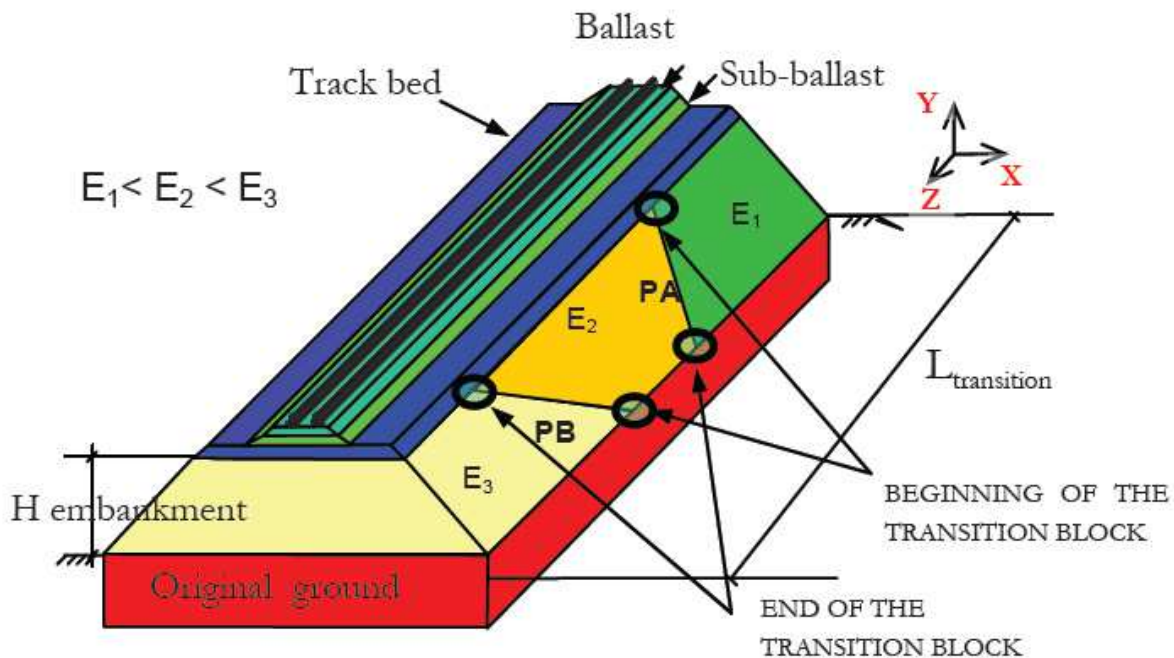

Fig. 2. General schematic of an embankment-structure. The transition is the zone adjacent to the structure (see Gallego I.,2006)

Suitable accuracy can be achieved by modeling only a transition section. However, the track section chosen to be modeled should be such that possesses the fundamental characteristics of a transition. However, the track section chosen for modeling should have the fundamental characteristics of a transition. For both slope types considered (PA and PB), these characteristics occur when the material changes from one material to another, either at the beginning or end of the slope (see Fig 2). Thus, the sections to be modeled are those shown within the rectangles in Fig 3.

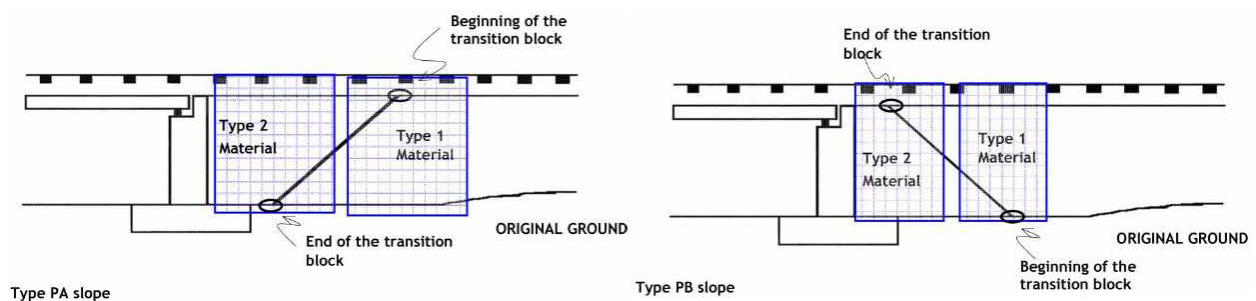

Fig. 3. Schematic of the beginning and end of the technical block in the slope of type PB and PA

4.2 Geometry of the analyzed domain

The directions considered for the model are the following ones: the axis x indicates the sleeper direction, the axis y the vertical and the axis z the rail direction (see Fig 2).

4.2.1 Transverse section

The measures adopted for the transversal section are the ones used in the High Speed line Madrid-Sevilla, but considering the track as simple and applying symmetry with respect to the plane $x = 0$.

The slope of the embankment varies with the type of material from which it is made; between $H/V=3/2$ and $1/2$. The value $3/2$ has been adopted in the model, because it was employed in the Madrid-Seville line.

4.2.2 Vertical direction

In the vertical direction (axis y) not only all the elements that compose the super structure are considered but also the, sub-ballast, the formation layer, 7m for the embankment and 3m for the original ground.

Values of 30, 25, and 60 cm, respectively were adopted for the thicknesses of the ballast under a sleeper, the sub-ballast the formation layer. These values are the same values as those applied in the transversal section of the High Speed line between Madrid and Seville.

4.2.3 Longitudinal direction

For domain analysis, the load applied on a sleeper is transmitted to the adjacent sleepers through some transmission coefficients. These coefficients clearly decrease as the distance from the point of load application increases; the coefficient is only 7 per cent in the third sleeper, when the first sleeper is defined as the one on which the load is applied (Comité D-117 (ORE), 1983)

To determine the real value of the settlement of the head of the rail when the load acts on it, one must not only solve for that load but also consider the history of the previous loads that have affected that sleeper. The load applied on a sleeper transmits it to the two adjacent sleepers. In order to observe the behavior of two consecutive sleepers with different stiffness under a load, while taking into account their load history also, four successively loaded sleepers (T5, T6, T7, and T8) were considered in order to analyze the behavior of sleepers T7 and T8.

In 1983, a test in Derby showed that important phenomena are apparent up to the fourth sleeper from the one loaded (Comité D-117 (ORE), 1983). Therefore, four unloaded sleepers were introduced at both ends of the model. This set-up avoided artefacts and yet included a substantial number of sleepers onto which the load could be applied. This approach required consideration of a transition sector comprising 12 sleepers, leading to a model system with a total length of 7.20 m.

4.3 Modelling rail track, elastic bearing, and sleeper section

In order to model the rail track, its resistance to bending was simulated in the most accurate way possible (Fig 4), which is why the inertia of the modelled rail must be equal to that of the real rail.

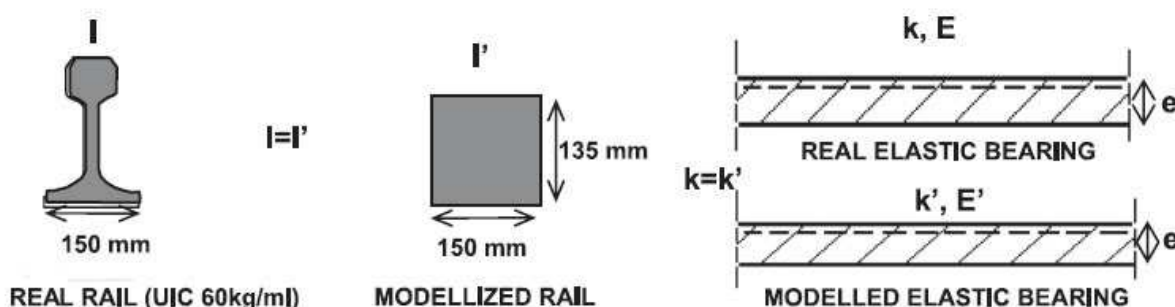

Fig. 4. Model of the rail and elastic bearings carried out in this study

The model also sought to make the vertical stiffness equal for all of the elastic bearings (see Fig 4). The vertical dimension and the modulus of elasticity were fixed so that the vertical stiffness of the element coincided with the stiffness of the elastic bearing provided by the manufacturer. For the high-speed Madrid-Seville line, the elastic bearings have a stiffness of nearly 500kN/mm (López A. , 2001)

Because the sleeper section is not constant along its entire length, the dimensions of its most representative section were used for the sleeper model elements. For each element (See Fig 5), the modeled flexural stiffness must be equal to the real flexural stiffness, as follows

$$E_{model}I_{model} = E_{real}I_{real} \tag{2}$$

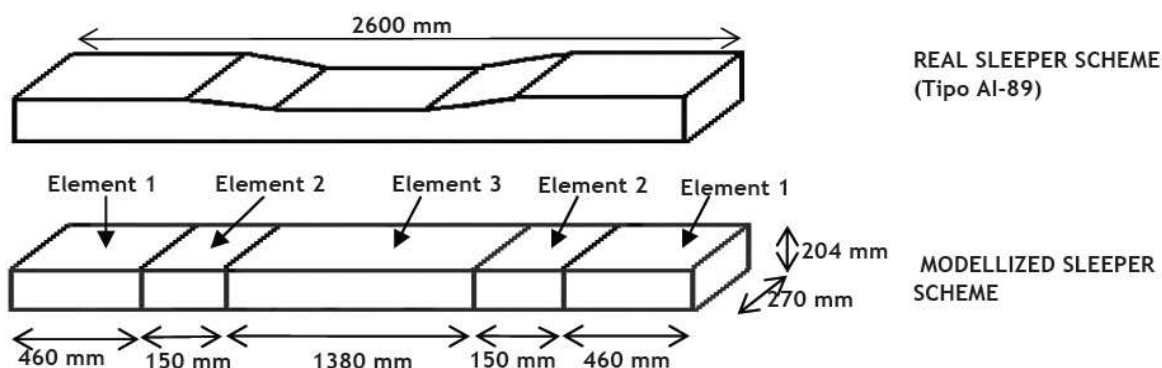

Fig. 5. Schematic of a real sleeper and a modeled sleeper

To obtain homogeneity in the calculations, the elements of the model had to have a constant width, which is not the case in the real sleeper. Thus, the model width must be considered to be an average width. This average width must be such that the load bearing surface in the model is equal to that in reality.

4.4 Sleeper-ballast contact

The sleeper-ballast contact zones contain a high concentration of strains. This local phenomenon requires refining of the mesh used to model these zones. However, applying this procedure is sometimes impossible because of the computational resources and model complexity needed. The most common alternative to modeling the contact zones is to use bounded degrees of freedom. In fact, this solution was adopted by ORE Committee D-117

and was used by the Railway Track Formations Project in its recommendations on railway track construction (Ministerio de fomento, 1999).

The use of bounded degrees of freedom requires the introduction of different nodes for each material at the contact surface. These nodes must move equivalently in the direction perpendicular to the contact plane (see Fig. 6). However, these nodes can move at different values in the directions parallel to the contact plane.

This solution is effective because it solves the tensional discontinuities that appear at the interface between two materials that differ significantly in their stiffness. In this model, bounded degrees of freedom were used at the sleeper-ballast contacts.

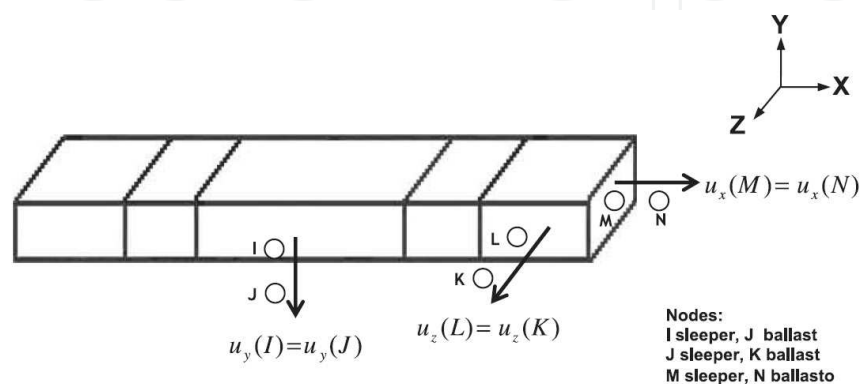

Fig. 6. Schematic of the ballast-sleeper contact

4.5 Boundary conditions

The model in this study differs from many existing models of railway track construction (Gallego, López, Ubalde, & Teixeira, 2005), in which all vertical planes are constrained in all directions. In the Supertrack project (European community, 2005) and in this work, the planes that shape the slopes of embankments are left completely free, with no restrictions. In particular, the boundary conditions used here are as follows (see Fig. 7):

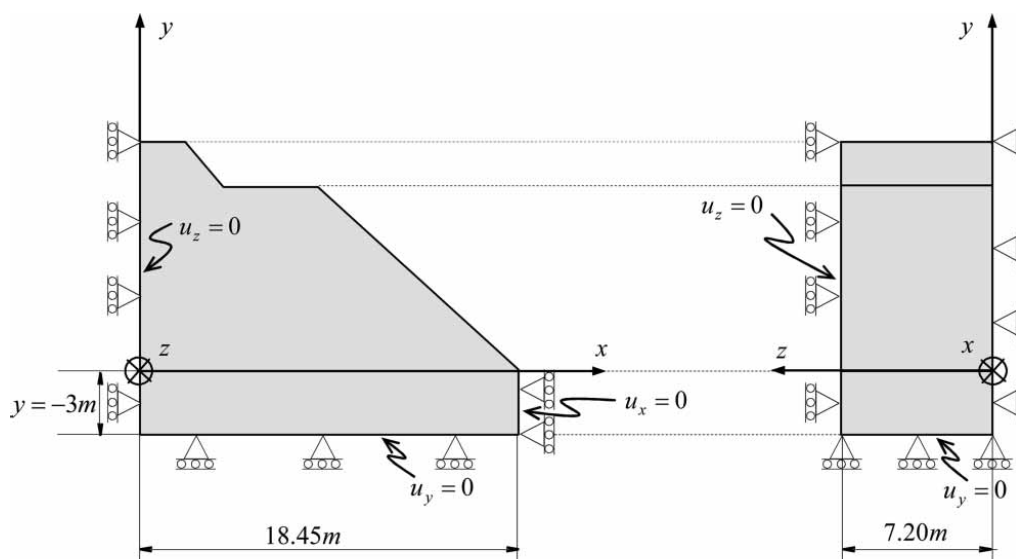

Fig. 7. Boundary conditions

- In the vertical plans limits of the model, $z=0$ and $z=7.20\text{m}$, the boundary condition adopted is to impose the nullity of movement in the perpendicular direction to these plans ($u_z=0$).
- In the vertical plans limits of the model, $x=0$ and $x=18.45\text{m}$, the boundary condition is, like the previous one, to impose the nullity of movement in the perpendicular direction to these plans ($u_x=0$).
- In the horizontal inferior plan of the model $y=-3\text{m}$, the condition to be imposed is the null vertical displacement ($u_y=0$).

4.6 Material constitutive model

An elastic, isotropic, and linear model was used to develop a mechanic model of the rail tracks, elastic bearings, sleepers, and the granular material processed with cement. In contrast, a perfect plastic model, i.e. the Drucker-Prager model (Oliver & Arlet, 2000), was used to model the rest of the materials, including the ballast, sub-ballast, track bed, embankment fill, and original ground. Finite strain was used to simulate the kinematics of the continuous medium.

Granular material treated with cement is considered to behave elastically, at least until it reaches a substantial percentage of its stress limit; one can assume its modulus of elasticity to remain essentially constant under normal stress.

To model the embankment material on which the track is laid, a perfect elasto-plastic behavior was assumed. This assumption implies that reloading occurs in the same way as downloading, and that the material experiences no hardening (hardening parameter $H=0$).

For modeling of the yield surfaces, the most accurate approach is to use a model dependent on hydrostatic pressure. These models are the Drucker-Prager and Mohr-Coulomb models, which limit the material behavior for states of hydrostatic stress (in traction). For the present study, the Drucker-Prager model was selected because it has been used in several elasto-plastic models used to design railway projects, and it has been validated by ORE Committee D-171.

The principle formulated by Drucker and Prager in 1952 includes the influence of pressure through the first invariant of the stress tensor I_1 and the internal friction angle ϕ . It also depends on the second invariant J_2 of the deviatoric stress tensor, as well as on two parameters: the friction angle among particles ϕ and the cohesion c . This criterion is expressed by means of the principal stress invariant and J_2 (the second invariant of deviatoric stress), as follows:

$$F(I_1, J_2, c; \phi) = \bar{\alpha}(\phi)I_1 + \sqrt{J_2} - \bar{K}(\kappa, \phi) = 0, \quad (3)$$

where

$$\bar{K}(\kappa, \phi) = 6 c(\kappa) \cos \phi / (3\sqrt{3} + \sqrt{3} \text{sen } \phi) \quad (4)$$

and

$$\bar{\alpha}(\phi) = 2 \text{sen } \phi / (3\sqrt{3} + \sqrt{3} \text{sen } \phi) \quad (5)$$

When the function that defines the yield surface (3) is represented in the main stress space, a cone is obtained, the axis of which is the hydrostatic axis (see Fig 8).

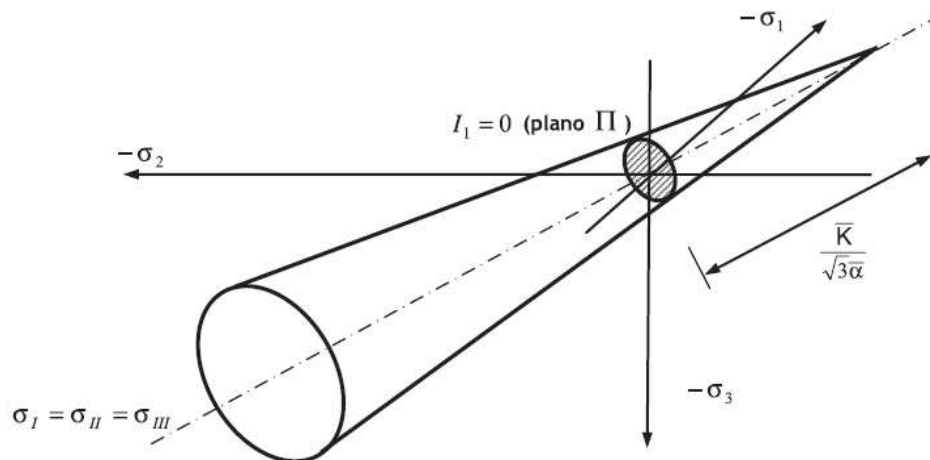

Fig. 8. Schematic of yield surfaces Drucker-Prager

Of the elements used, a quadratic ‘brick’ element of 20 nodes was selected; this is the most common type of element in three-dimensional models used to design railway tracks. The final meshes are shown in Fig 9.

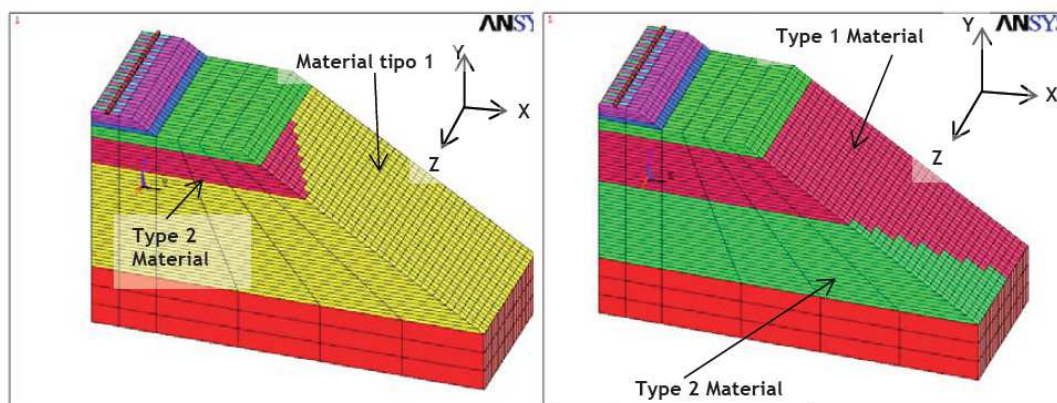
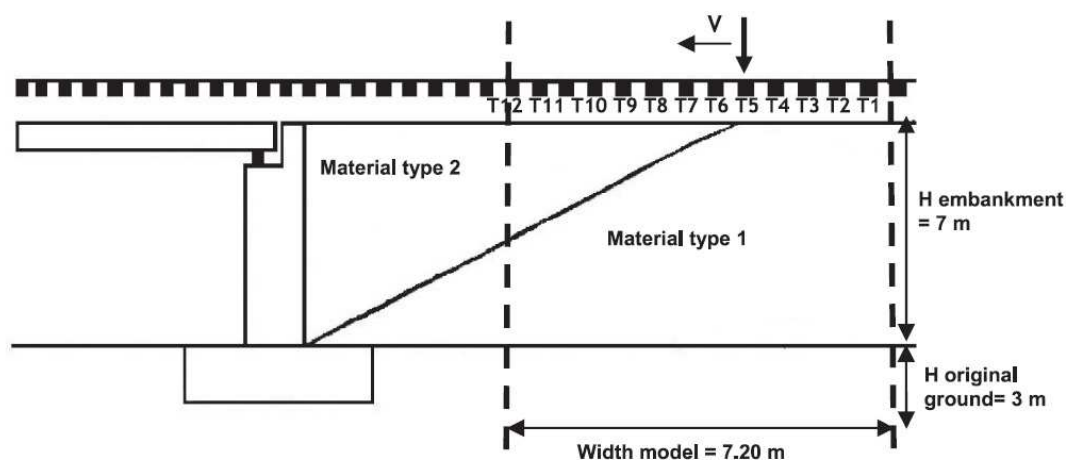

Fig. 9. Finite-element model for transitions with slopes of type PA31 and PB11

4.7 Hypothesis adopted

The load application must be carried out in several stages. In the first stage, only the material’s own weight is considered until reaching the stress balance, while at later stages the loads due to the train are also taken into account. The stresses and displacements of interest are the ones that correspond to the application of the train loads; therefore, they can be calculated from the difference between the totals obtained after applying the train loads to the first stage.

Here, it was convenient to apply four load states due to the train passage, matching each state to the application of the static load per wheel in the four central sleepers of the model: T5, T6, T7, and T8 (See Fig 10).



Load state 1 (LS1): only own weight

Load state 2 (LS2): static load on sleeper T5

Load state 3 (LS3): T5 sleeper download and T6 load

Load state 4 (LS4): T6 sleeper download T6 and T7 load

Load state 5 (LS5): T7 sleeper download and T8 load

Fig. 10. Schematic of the different load states

To simulate the constructive process of an embankment and to ensure convergence of the solution, the first load state (only the material weight) was divided into 250 substeps of the gravitational load application and 50 balance iterations for each one. For railway loads, 15 sub-steps proved to be sufficient to achieve convergence. The program used is ANSYS Structural, which enables nonlinear analysis.

To carry out the calculations, the load of only one axle was considered while assuming the effects of the remaining axles to be negligible.

The increased value of the dynamic overloads was calculated using Prud'Homme's formulation, with 1mm used as the value for b and the speed set to be 300 km/h. With this approach, the value of a dynamic overload was obtained according to the dynamic stiffness, which is unknown because its calculation requires knowing the value of the point dynamic load on the track. It is customary to carry out railway calculations assuming that the dynamic stiffness has a value similar to that of the static stiffness; this assumption has been validated by experience and confirmed by calculations (Ministerio de fomento, 1999). Thus, this assumption was also made in the present study, and numerical tests were used to justify this choice.

5. Results from the model: Presentation and critical analysis

This modeling study was carried out in two phases with different aims. In the first phase, different case studies were analyzed numerically, and the results were studied. These results then determined whether to carry out more case studies or proceed with the second phase. The main objective of the first phase was to observe how changing from a less rigid material to a more rigid one would affect the vertical stiffness of the track.

In the second phase, variations caused by the different stiffness values were analyzed for all the case studies from the first phase.

5.1 First phase

In the first phase, the main differences among the designs of the embankment-structure transitions are the types of materials used and the construction design. This justifies defining two types of case studies based on different geotechnical and geometrical parameters.

The geometrical parameters include the type and grade of slope; the latter is defined, e.g., as 1 : 1 and 3 : 2 ($H : V$, horizontal and vertical). The geotechnical parameters are the modulus of elasticity of the materials that compose the embankment fill and the original ground. For the modulus of elasticity, a range of values was used, matching those adopted in the numerical model presented by ORE Committee D-117. The values coincide with the lower limit values corresponding to the material types QS1, QS2, QS3, and rock (see Tab 1).

To fill the embankment, granular material processed with cement (MGT) was added to the model, since this material is so frequently used. Combining all these values with the technical block and the four load states already described, yielded a total of 48 case studies (see Tab 2). The modeling results for the case studies are shown in Tab 3.

To make additional comparisons, the stiffness was calculated for cases in which the fill corresponded to conventional embankments made with the same type of material (see Tab 4).

1. It is useful to apply stiffness values not only at the beginning but also at the end of the technical block; therefore, the cases corresponding to the ends of the technical blocks were calculated. Since the calculated stiffness values in the first 48 cases were similar for original ground QS1 and QS2, and for QS3 and rock, it was sufficient to calculate the cases corresponding to QS2 and QS3, thereby reducing the number of cases from 48 to 24 (see Tab 5).

5.2 Second phase

The second phase involved analyzing the results of the first phase. The criteria were to limit the following:

- The upper value of the vertical stiffness
- The lower value of the vertical stiffness
- The value of the longitudinal variation

TRANSITION TYPE	ORIGINAL GROUND QS1	ORIGINAL GROUND QS2	ORIGINAL GROUND QS3	ORIGINAL GROUND ROCK
H7PA11QS2QS3	11.242	17.227	37.206	42.752
H7PB11QS2QS3	18.847	19.957	36.054	39.325
H7PA31QS2QS3	10.800	16.380	34.139	39.744
H7PB31QS2QS3	14.015	19.296	34.519	38.512
H7PA11QS2MGT	15.380	25.499	43.859	47.795
H7PB11QS2MGT	28.721	32.644	37.657	40.000
H7PA31QS2MGT	13.182	18.275	36.549	42.077
H7PB31QS2MGT	21.524	25.961	35.777	38.592
H7PA11QS3MGT	32.193	53.563	71.692	75.374
H7PB11QS3MGT	54.186	59.936	69.294	70.473
H7PA31QS3MGT	29.354	51.068	70.875	74.650
H7PB31QS3MGT	48.668	58.069	70.340	73.444

Table 3. Values of vertical static track stiffness at the beginning of transition K_l (kN/mm) for all cases studied

EMBANKMENT MATERIAL	ORIGINAL GROUND QS1	ORIGINAL GROUND QS2	ORIGINAL GROUND QS3	ORIGINAL GROUND ROCK
FULL QS2 ($K(QS2)$)	10.186	15.717	33.226	38.433
FULL QS3 ($K(QS3)$)	28.899	50.929	70.606	74.027
FULL MGT ($K(MGT)$)	67.782	73.676	83.214	87.800

Table 4. Values of vertical static track stiffness K for conventional embankments (kN/mm)

TRANSITION TYPE	ORIGINAL GROUND QS2		ORIGINAL GROUND QS3	
	BEGINNING (K_I)	END (K_F)	BEGINNING (K_I)	END (K_F)
H7PA11QS2QS3	17.227	37.581	37.206	61.927
H7PB11QS2QS3	19.957	47.071	36.054	64.276
H7PA31QS2QS3	16.380	41.982	34.139	65.175
H7PB31QS2QS3	19.296	49.312	34.519	67.536
H7PA11QS2MGT	25.499	62.550	43.859	72.812
H7PB11QS2MGT	32.644	66.571	37.657	80.345
H7PA31QS2MGT	18.275	68.029	36.549	76.708
H7PB31QS2MGT	25.961	69.294	35.777	79.658
H7PA11QS3MGT	53.563	68.278	71.692	79.658
H7PB11QS3MGT	59.936	71.145	69.294	78.319
H7PA31QS3MGT	51.068	71.418	70.875	82.844
H7PB31QS3MGT	58.069	71.009	70.340	82.115

Table 5. Values of vertical static track stiffness at the beginning K_I and end of transition K_F (kN/mm) for all cases studied

These criteria were applied in two steps. Initially, the first two criteria were applied, and solutions were discarded if they resulted in either very high stiffness values, which generate elevated dynamic overloads, or very low stiffness values, which generate excessive rail deformations of the rail. To determine whether the stiffness values were high or low, they were compared to the values for designs using the same original ground material and the same materials as the simulated transition. Tab 6 shows the solutions remaining after this elimination process.

Materials of transition: Type1/Type 2	ORIGINAL GROUND QS1	ORIGINAL GROUND QS2	ORIGINAL GROUND QS3	ORIGINAL GROUND ROCK
QS2/QS3	PB31 PA11	PB31 PA11	PB11 PA31	PB11 PA31
QS2/MGT	PB31 PA11	PB31 PA11	PB11 PA31	PB11 PA31
QS3/MGT	PB31 PA11	PB31 PA11	PB31 PA31	PB31 PA31

Table 6. Transition types obtained after eliminating the transition types that with extreme stiffness values

The second step consisted of applying the third criterion, limiting the longitudinal variation value. From among the case studies, the cases selected were those with the smallest increase in the K value at the beginning and end of the technical blocks. In this way, the most appropriate solutions were obtained for each type of original ground material (QS2 and QS3). This approach yields certain design recommendations, which are described in the following section.

6. Proposed design recommendations

The analysis identified some problems related to the type of material. Based on these, the most relevant recommendations include:

- Excessive deformations were observed in the rail when material of type QS1 exists in the original ground (see Fig 11). These deformations reached 14mm under the rail when transitions QS2 and QS3 were used (Tab 7). In these cases, the deformations were large, as were the deformation values between adjacent sleepers. For this reason, it is appropriate to substitute the original ground material of type QS1 with another material or to treat the existing QS1 material in such a way as to obtain a modulus of elasticity corresponding to that of a material of at least type QS2.

In transitions from material of type QS2 to treated granular material, which occurs commonly in buried structures, the stiffness increased significantly at the beginning of the technical block when there was a relatively compressible material in the original ground. The solution with the smallest increase in the stiffness value was PA31. Fig 12 shows this value to be 16.4% which is too large. For this reason, transition-type QS2/MGT is not appropriate for use in the surface structure.

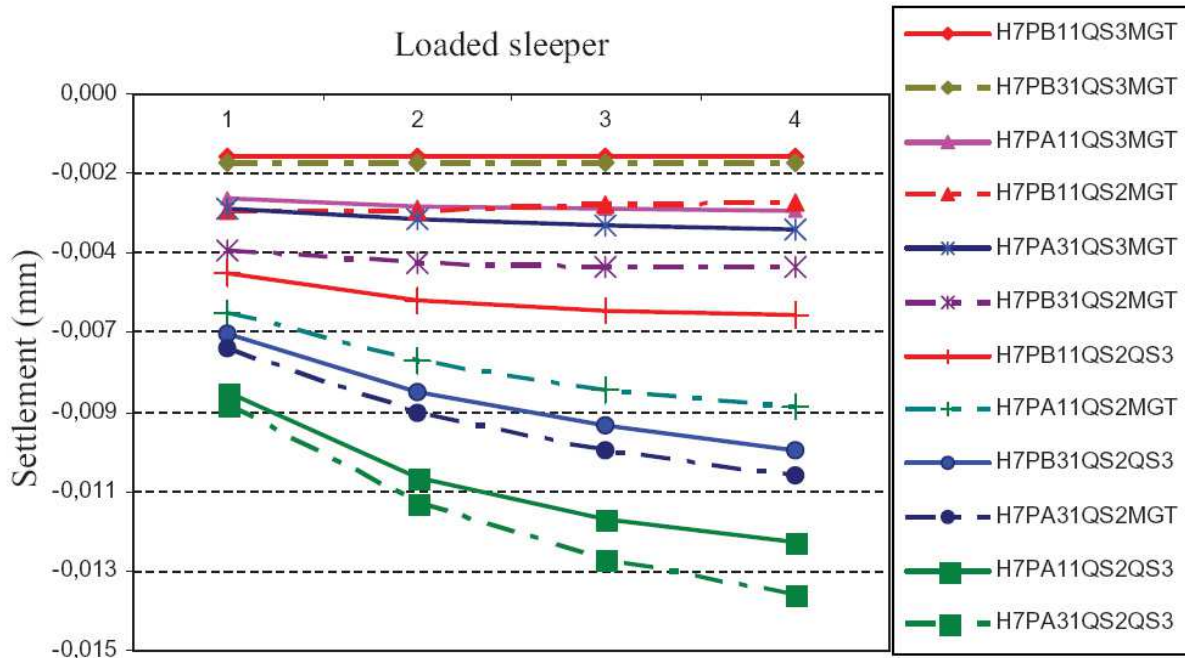

Fig. 11. Deflection of the head of loaded rails

	SLEEPER 5	SLEEPER 6	SLEEPER 7	SLEEPER 8
H7PA11QS2QS3				
LOADED SLEEPER 5	-0.0083	-0.0077	-0.0069	-0.0063
LOADED SLEEPER 6	-0.0104	-0.0106	-0.0100	-0.0091
LOADED SLEEPER 7	-0.0113	-0.0117	-0.0118	-0.0112
LOADED SLEEPER 8	-0.0117	-0.0120	-0.0123	-0.0125
H7PB11QS2QS3				
LOADED SLEEPER 5	-0.0050	-0.0045	-0.0038	-0.0032
LOADED SLEEPER 6	-0.0054	-0.0057	-0.0052	-0.0044
LOADED SLEEPER 7	-0.0051	-0.0057	-0.0060	-0.0055
LOADED SLEEPER 8	-0.0049	-0.0054	-0.0059	-0.0062
H7PA31QS2QS3				
LOADED SLEEPER 5	-0.0086	-0.0081	-0.0074	-0.0069
LOADED SLEEPER 6	-0.0111	-0.0114	-0.0109	-0.0101
LOADED SLEEPER 7	-0.0121	-0.0126	-0.0129	-0.0124
LOADED SLEEPER 8	-0.0127	-0.0131	-0.0136	-0.0139
H7PB31QS2QS3				
LOADED SLEEPER 5	-0.0067	-0.0062	-0.0055	-0.0049
LOADED SLEEPER 6	-0.0079	-0.0083	-0.0078	-0.0071
LOADED SLEEPER 7	-0.0083	-0.0089	-0.0092	-0.0087
LOADED SLEEPER 8	-0.0085	-0.0090	-0.0096	-0.0099
H7PA11QS2MGT				
LOADED SLEEPER 5	-0.0061	-0.0056	-0.0048	-0.0043
LOADED SLEEPER 6	-0.0072	-0.0074	-0.0069	-0.0062
LOADED SLEEPER 7	-0.0074	-0.0079	-0.0082	-0.0077
LOADED SLEEPER 8	-0.0076	-0.0080	-0.0084	-0.0087
H7PB11QS2MGT				
LOADED SLEEPER 5	-0.0032	-0.0027	-0.0020	-0.0015
LOADED SLEEPER 6	-0.0030	-0.0032	-0.0027	-0.0020
LOADED SLEEPER 7	-0.0026	-0.0029	-0.0031	-0.0026
LOADED SLEEPER 8	-0.0022	-0.0025	-0.0028	-0.0030
H7PA31QS2MGT				
LOADED SLEEPER 5	-0.0071	-0.0066	-0.0059	-0.0053
LOADED SLEEPER 6	-0.0086	-0.0089	-0.0084	-0.0077
LOADED SLEEPER 7	-0.0091	-0.0096	-0.0099	-0.0094
LOADED SLEEPER 8	-0.0094	-0.0098	-0.0103	-0.0106
H7PB31QS2MGT				
LOADED SLEEPER 5	-0.0043	-0.0038	-0.0031	-0.0025
LOADED SLEEPER 6	-0.0044	-0.0047	-0.0042	-0.0034
LOADED SLEEPER 7	-0.0040	-0.0045	-0.0048	-0.0043
LOADED SLEEPER 8	-0.0036	-0.0040	-0.0045	-0.0048
H7PA11QS3MGT				
LOADED SLEEPER 5	-0.0029	-0.0025	-0.0020	-0.0016
LOADED SLEEPER 6	-0.0028	-0.0031	-0.0027	-0.0022
LOADED SLEEPER 7	-0.0024	-0.0029	-0.0032	-0.0028
LOADED SLEEPER 8	-0.0021	-0.0025	-0.0029	-0.0032
H7PB11QS3MGT				
LOADED SLEEPER 5	-0.0017	-0.0014	-0.0010	-0.0007
LOADED SLEEPER 6	-0.0015	-0.0017	-0.0014	-0.0010
LOADED SLEEPER 7	-0.0011	-0.0015	-0.0017	-0.0014
LOADED SLEEPER 8	-0.0008	-0.0011	-0.0015	-0.0017
H7PA31QS3MGT				
LOADED SLEEPER 5	-0.0032	-0.0028	-0.0022	-0.0018
LOADED SLEEPER 6	-0.0031	-0.0035	-0.0031	-0.0025
LOADED SLEEPER 7	-0.0028	-0.0033	-0.0036	-0.0033
LOADED SLEEPER 8	-0.0025	-0.0029	-0.0034	-0.0037
H7PB31QS3MGT				
LOADED SLEEPER 5	-0.0019	-0.0016	-0.0012	-0.0009
LOADED SLEEPER 6	-0.0017	-0.0019	-0.0016	-0.0012
LOADED SLEEPER 7	-0.0013	-0.0017	-0.0019	-0.0016
LOADED SLEEPER 8	-0.0010	-0.0013	-0.0016	-0.0019

Table 7. Settlements of rail for the different load steps. Case study: original ground QS1

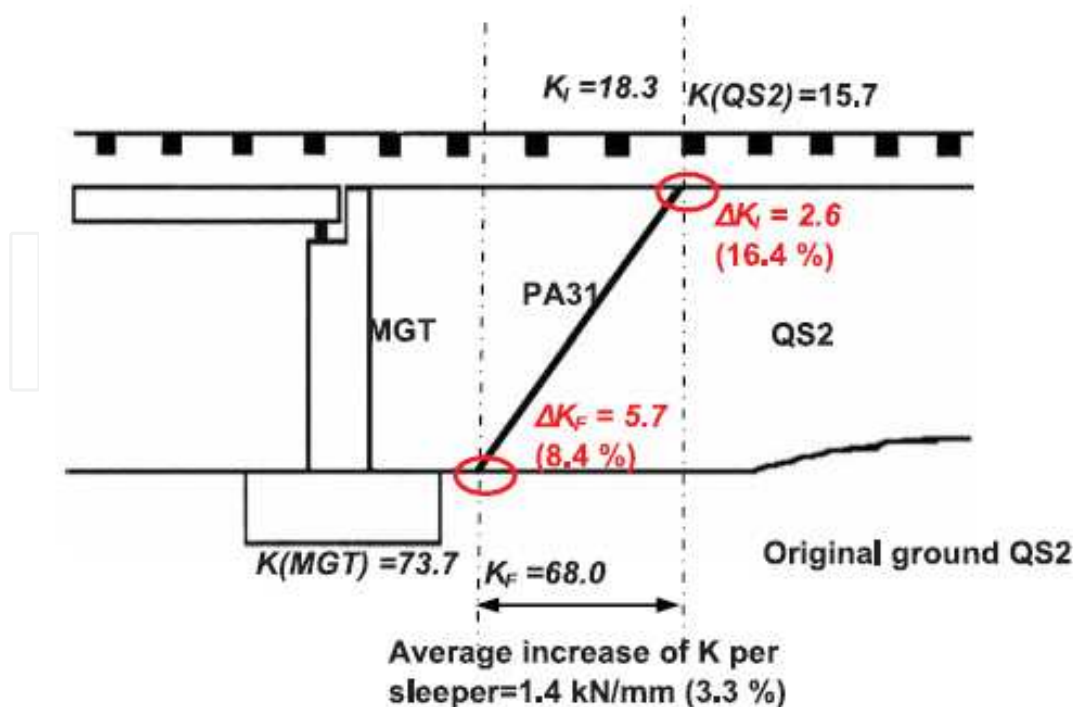

Fig. 12. Analysis of the stiffness variations assuming material transition from type QS2 to granular treated material

- Near the abutment, the stiffness increased abruptly when using a granular material treated with cement as fill (MGT, 3% by weight). In fact, the stiffness value of the abutment could oscillate between 200KN/mm and 300KN/mm. The maximum of 87.8 KN/mm obtained for the case of treated granular material (Tab 4) is outside of that range. In this case, it is necessary to put a material with greater stiffness than MGT next to the abutment.
- A direct transition from QS2 or QS3 material to the structure is not recommended. At best, the stiffness is 38.43 KN/mm when the embankment material is QS2 and 74.027 KN/mm if it is QS3 (see Tab 4), as compared to 200-300 KN/mm of vertical stiffness on the abutment.
- It is sometimes necessary to build the embankment adjacent to the abutment before building the structure. For example, this occurs when the original ground adjacent to the abutment is preloaded, and the load is removed immediately before building the transition. In that case, a slope of type PA (right column) is used instead of a slope of type PB (left column) in the transition from embankment material QS2 to QS3. In this research, a suitable value is obtained for the slope of the transition for each type (PA, PB). For that reason, it is necessary to distinguish between both slope types when considering whether a better approach would be to build the embankment before or after fabricating the structure.

In this way, based on these analyses, this study can make some recommendations about construction designs. Moreover, this study has proposed some ideas relating to the geometric designs of the different materials and has classified the designs according to the original ground and according to when the adjacent embankment is built, either before or after the construction of the structure (Fig 13).

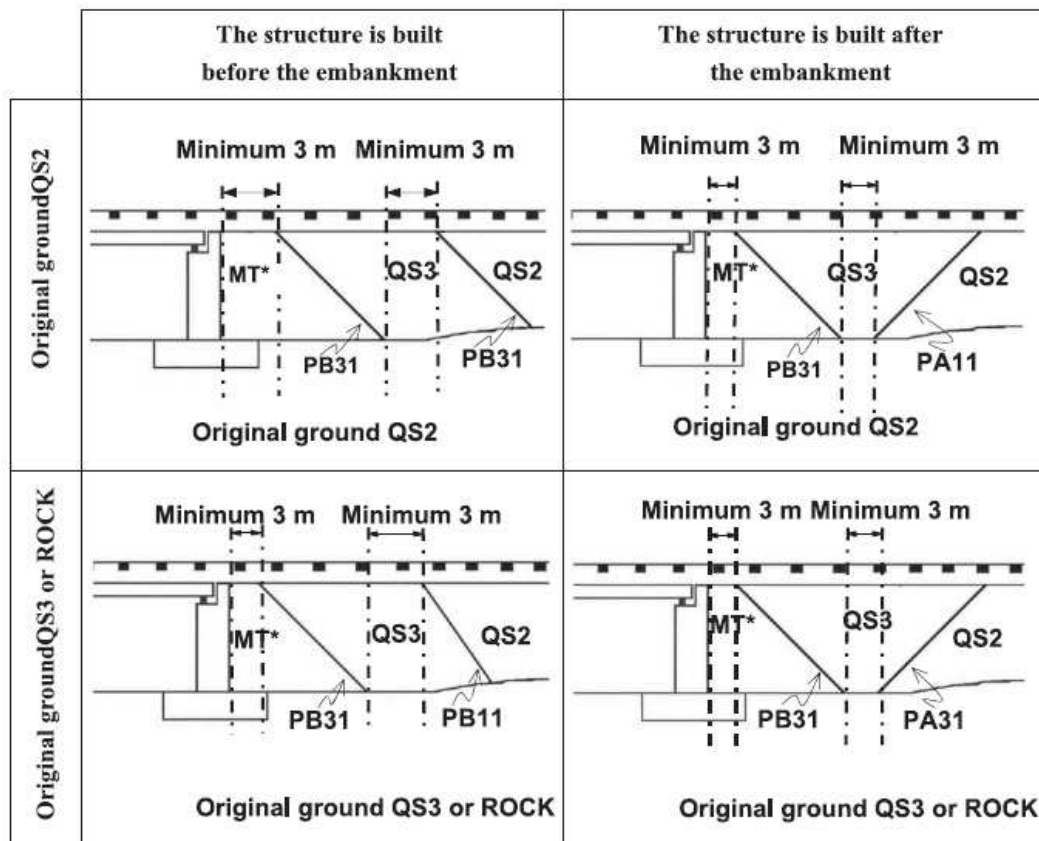

Fig. 13. Proposed design schemes

7. Conclusions

The designs currently used in embankment–structure transitions lead to zones that suffer significant deterioration. In addition, the various European railway systems have adopted many different design specifications when constructing these zones.

Increased railway speeds enhance the deterioration problems in the embankment–structure transitions, which has important implications for operating and maintenance costs, as well as for passenger safety and comfort.

From the numerical analysis carried out in this study, the following conclusions are drawn:

- The embankment must not be built on excessively compressible material, as shown for material of type QS1 on original ground. Such material must be replaced with another material or treated to obtain a modulus of elasticity corresponding to that of a material of at least type QS2.
- Transitions from material of type QS2 to material of type MGT should be carried out when there the original ground is of type QS3, or when the buried structure is treated.
- For each disposition type (PA, PB), there exists an optimal value for the slope. This value is not always the lowest one (3:1), as expected. The most suitable slope value (3:1 or 1:1) depends on the of original ground material, on the disposition type, and on the materials used in the transition.

- An abrupt increase in the stiffness takes place when a granular material treated with cement (MGT at 3% by weight) is used near the abutment. This problem remains unresolved, but future solutions should focus on improving the modulus of elasticity of the material without producing excessive stiffness increases at the extremes of the transition from the material of type QS3 to the treated material.

The application of all of those conclusions leads to a succession of recommendations for the most suitable building designs. When developing such designs, those factors which have an influence on the transition behavior (original ground, transition materials, and slope type) must be considered.

8. References

- Amielin, S. (1974). *La vía y el servicio de vía*. (Spanish translation from the original in Russian, by Fundación de los Ferrocarriles Españoles).
- Comité D-117 (ORE). (1983). *Adaptation optimale de la voie classique au trafic de l'avenir. Rapport no. 27. Comportement des structures d'assise de la voiesous charges répétées*. Office de Recherches et d'Essais del'Union Internationale des Chemins de Fer.
- Esveld, C. (2001). *Modern railway track*. The Netherlands: MRTProductions.
- European community. (2005). *Sustained Performance of Railway Tracks-SUPERTRACK Project Numerical simulation of train-track dynamics*.
- European Rail Research Institute, ERRI. (1999). *Code D-230.1/RP3, Bridge ends embankment. Structure transitions*.
- Gallego, I. (2006). *Heterogeneidad resistente de las vías de Alta Velocidad: Transición terraplén-estructura.6*. Ciudad Real: Doctoral Thesis, University of Castilla-La Mancha.
- Gallego, I., & López, A. (2009). Numerical simulation of embankment-structure transition design. *Journal of Rail and Rapid Transit*, 223, 331-342.
- Gallego, I., López, A., Ubalde, L., & Texeira, P. (2005). Track deterioration in high-speed railways: the influence of longitudinal variatioical stiffrrness in the embankment-structure transitions. *Congress on Railway Engineering*. London.
- Hettle, A. (1986). *Modelluntersuchungen der Gleissetzungen am Übergang Brücke (Studies in a reduced scale model on the track sinking/downfall/collapse in a section of a bridge/embankment transition)*. *ETR (Spanish translation from the original in German)*.
- Hunt, H. (1997). Settlement of railway track near bridge abutment. *Proc. Instn. Civil Engrs. Transp*, (págs. 68-73).
- López, A. (1977). Análisis de la deformabilidad vertical de una vía férrea mediante el método de elementos finitos. *AIT* (15).
- Lopez, A. (1983). La heterogeneidad resistente de una vía y su incidencia en la evolución de la nivelación longitudinal: una aproximación al problema. *Revista de Obras Públicas*, 719-735.
- López, A. (2001). La rigidez vertical de la vía y el deterioro de las líneas de alta velocidad. *Revista de Obras Públicas*, 222-232.
- Ministerio de fomento. (1999). *Recomendaciones para el proyecto de plataformas ferroviarias*. Madrid: Servicio de publicaciones del Ministerio de Fomento.
- Mira, P., Fernández, J., Pastor, M., Nasarre, J., & Carrillo, J. (2000). Aplicaciones del método de elementos finitos a la ingeniería ferroviaria. *Revista de Ingeniería Civi* (118), 71-82.

- Oliver, X., & Arlet, C. (2000). *Mecánica de medios continuos para ingenieros*. Barcelona: Ediciones UPC.
- Profillidis, V. (1983). *La voie et sa fondation modelisation mathematique*. Paris: Doctoral Thesis, École Nationale des Ponts et Chaussées.
- Prud`Homme, M. A. (1970). La voie. *Revue Générales des Chemins de Fer* .
- Sahu, J., Rao, & Yudhbir. (1999). Parametric study of resilient response of tracks with a sub-ballast layer. *Canadian Geotechnical Journal* , 36, 1137-1150.
- Sauvage, G., & Larible, G. (1982). La modélisation par éléments finis des couches d`assise de la voie ferrée. *Revue Générale des Chemins de Fer* , 475-484.
- Teixeira, P. F. (2003). *Contribución a la reducción de los costes de mantenimiento de vías de alta velocidad mediante la optimización de su rigidez vertical*. Doctoral Thesis, Polytechnic University of Cataluña.

IntechOpen

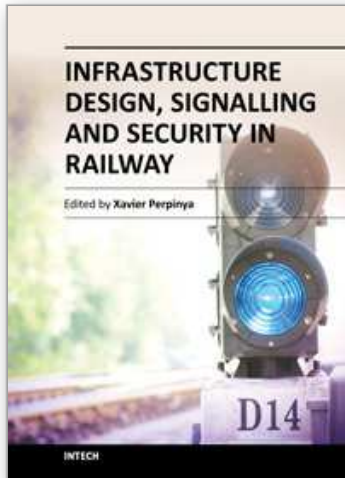

Infrastructure Design, Signalling and Security in Railway

Edited by Dr. Xavier Perpinya

ISBN 978-953-51-0448-3

Hard cover, 522 pages

Publisher InTech

Published online 04, April, 2012

Published in print edition April, 2012

Railway transportation has become one of the main technological advances of our society. Since the first railway used to carry coal from a mine in Shropshire (England, 1600), a lot of efforts have been made to improve this transportation concept. One of its milestones was the invention and development of the steam locomotive, but commercial rail travels became practical two hundred years later. From these first attempts, railway infrastructures, signalling and security have evolved and become more complex than those performed in its earlier stages. This book will provide readers a comprehensive technical guide, covering these topics and presenting a brief overview of selected railway systems in the world. The objective of the book is to serve as a valuable reference for students, educators, scientists, faculty members, researchers, and engineers.

How to reference

In order to correctly reference this scholarly work, feel free to copy and paste the following:

Inmculada Gallego, Santos Sánchez-Cambronero and Ana Rivas (2012). Criteria for Improving the Embankment-Structure Transition Design in Railway Lines, Infrastructure Design, Signalling and Security in Railway, Dr. Xavier Perpinya (Ed.), ISBN: 978-953-51-0448-3, InTech, Available from: <http://www.intechopen.com/books/infrastructure-design-signalling-and-security-in-railway/criteria-for-improving-the-embankment-structure-transition-design-in-railway-lines>

INTECH
open science | open minds

InTech Europe

University Campus STeP Ri
Slavka Krautzeka 83/A
51000 Rijeka, Croatia
Phone: +385 (51) 770 447
Fax: +385 (51) 686 166
www.intechopen.com

InTech China

Unit 405, Office Block, Hotel Equatorial Shanghai
No.65, Yan An Road (West), Shanghai, 200040, China
中国上海市延安西路65号上海国际贵都大饭店办公楼405单元
Phone: +86-21-62489820
Fax: +86-21-62489821

© 2012 The Author(s). Licensee IntechOpen. This is an open access article distributed under the terms of the [Creative Commons Attribution 3.0 License](#), which permits unrestricted use, distribution, and reproduction in any medium, provided the original work is properly cited.

IntechOpen

IntechOpen