

We are IntechOpen, the world's leading publisher of Open Access books Built by scientists, for scientists

5,200

Open access books available

128,000

International authors and editors

150M

Downloads

Our authors are among the

154

Countries delivered to

TOP 1%

most cited scientists

12.2%

Contributors from top 500 universities



WEB OF SCIENCE™

Selection of our books indexed in the Book Citation Index
in Web of Science™ Core Collection (BKCI)

Interested in publishing with us?
Contact book.department@intechopen.com

Numbers displayed above are based on latest data collected.
For more information visit www.intechopen.com



Advanced Control Techniques for the Transonic Phase of a Re-Entry Flight

Gianfranco Morani, Giovanni Cuciniello,
Federico Corraro and Adolfo Sollazzo
Italian Aerospace Research Centre (CIRA)
Italy

1. Introduction

New technological developments in space engineering and science require sophisticated control systems with both high performance and reliability. How to achieve these goals against various uncertainties and off-nominal scenarios has been a very challenging issue for control system design over the last years.

Several efforts have been spent on control systems design in aerospace applications, in order to conceive new control approaches and techniques trying to overcome the inherent limitations of classical control designs.

In fact, the current industrial practice for designing flight control laws is based on Proportional Integral Derivative (PID) controllers with scheduled gains. With this approach, several controllers are designed at various points in the operative flight envelope, considering local time-invariant linear models based on small perturbations of a detailed nonlinear aircraft model. Although these techniques are commonly used in control systems design, they may have inherent limitations stemming from the poor capability of guaranteeing acceptable performances and stability for flight conditions different from the selected ones, especially when the scheduling parameters rapidly change.

This issue becomes very critical when designing flight control system for space re-entry vehicles. Indeed, space reentry applications have some distinctive features with respect to aeronautical ones, mainly related to the lack of stationary equilibrium conditions along the trajectories, to the wide flight envelope characterizing missions (from hypersonic flight regime to subsonic one) and to the high level of uncertainty in the knowledge of vehicle aerodynamic parameters.

Over the past years, several techniques have been proposed for advanced control system development, such as Linear Quadratic Optimal Control (LQOC), Eigenstructure Assignment, Robust control theory, Quantitative feedback theory (QFT), Adaptive Model Following, Feedback Linearization, Linear Parameter Varying (LPV) and probabilistic approach. Hereinafter, a brief recall of the most used techniques will be given.

Linear Quadratic Optimal Control (LQOC) allows finding an optimal control law for a given system based on a given criterion. The optimal control can be derived using Pontryagin's maximum principle and it has been commonly applied in designing Linear Quadratic Regulator (LQR) of flight control system (see Xing, 2003; Vincent et al., 1994).

The Eigenstructure Assignment consists of placing the eigenvalues of a linear system using state feedback and then using any remaining degrees of freedom to align the eigenvectors as accurately as possible (Konstantopoulos & Antsaklis, 1996; Liu & Patton, 1996; Ashari et al., 2005). Nevertheless there are several limitations, since only linear systems are considered and moreover the effects of uncertainty have been not extensively studied.

Robust analysis and control theory is a method to measure performance degradation of a control system when considering system uncertainties (Rollins, 1999; Balas, 2005). In this framework a concept of structured singular value (i.e μ -Synthesis) is introduced for including structured uncertainties into control system synthesis as well as for checking robust stability of a system.

Adaptive Model Following (AMF) technique has the advantage of strong robustness against parameter uncertainty of the system model, if compared to classical control techniques (Bodson & Grosziewicz, 1997; Kim et al., 2003). The model following approach has interesting features and it may be an important part of an autonomous reconfigurable algorithm, because it aims to emulate the performance characteristics of a target model, even in presence of plant's uncertainties.

Another powerful nonlinear design is Feedback Linearization which transforms a generic non linear system into an equivalent linear system, through a change of variables and a suitable control input (Bharadwaj et al., 1998; Van Soest et al., 2006). Feedback linearization is an approach to nonlinear control design which is based on the algebraic transformation of nonlinear systems dynamics into linear ones, so that linear control techniques can be applied.

More recently an emerging approach, named Linear Parameter Varying (LPV) control, has been developed as a powerful alternative to the classical concept of gain scheduling (Spillman, 2000; Malloy & Chang, 1998; Marcos & Balas, 2004). LPV techniques are well suited to account for on-line parameter variations such that the controllers can be designed to ensure performance and robustness in all the operative envelope. In this way a gain-scheduling controller can be achieved without interpolating between several design points.

The main effort (and also main drawback) required by the above techniques is the modelling of a nonlinear system as a LPV system. Several techniques exist but they may require a huge effort for testing controller performances on the nonlinear system. Other modelling techniques try to overcome this problem at the expense of a higher computational effort.

Finally in the last decades, a new philosophy has emerged, that is, probabilistic approach for control systems analysis and synthesis (Calafiore et al., 2007; Tempo et al., 1999; Tempo et al., 2005). In this approach, the meaning of robustness is shifted from its usual deterministic sense to a probabilistic one. The new paradigm is then based on the probabilistic definition of robustness, by which it is claimed that a certain property of a control system is "almost" robustly satisfied, if it holds for "most" instances of uncertainties. The algorithms based on probabilistic approach, usually called randomized algorithms (RAs), often have low complexity and are associated to robustness bounds which are less conservative than classical ones, obviously at the expense of a probabilistic risk.

In this chapter the results of a research activity focused on the comparison between different advanced control architectures for transonic phase of a reentry flight are reported. The activity has been carried out in the framework of Unmanned Space Vehicle (USV) program of Italian Aerospace Research Centre (CIRA), which is in charge of developing unmanned space Flying Test Beds (FTB) to test advanced technologies during flight. The first USV

Dropped Transonic Flight Test (named DTFT1) was carried out in February 2007 with the first vehicle configuration of USV program (named FTB1) (see Russo et al., 2007 for details). For this mission, a conventional control architecture was implemented. DTFT1 was then used as a benchmark application for comparison among different advanced control techniques. This comparison aimed at choosing the most suited control technique to be used for the subsequent, more complex, dropped flight test, named DTFT2, successfully carried out on April 2010. To this end, three techniques were selected after a dedicated literature survey, namely:

- μ -Control with Fuzzy Logic Gain-Scheduling
- Direct Adaptive Model Following Control
- Probabilistic Robust Control Synthesis

In the next sections, the above techniques will be briefly described with particular emphasis on their application to DTFT1 mission. In sec. 5 the performance analysis carried out for comparison among the different techniques will be presented.

2. Fuzzy scheduled MU-controller

2.1 The H^∞ control problem

The H^∞ Control Theory (Zhou & Doyle, 1998) rises as response to the deficiencies of the classical Linear Quadratic Gaussian (LQG) control theory of the 1960s applications. The general problem formulation is described through the following equations:

$$\begin{bmatrix} z \\ y \end{bmatrix} = P(s) \begin{bmatrix} w \\ u \end{bmatrix} = \begin{bmatrix} P_{11} & P_{12} \\ P_{21} & P_{22} \end{bmatrix} \begin{bmatrix} w \\ u \end{bmatrix} \quad (1)$$

$$u = K(s)y$$

where P is the nominal plant, u is the control variable, y is the measured variable, w is an exogenous signals (such as disturbances) and z is the error signal to be minimized. The generic control scheme is depicted in Fig 1.

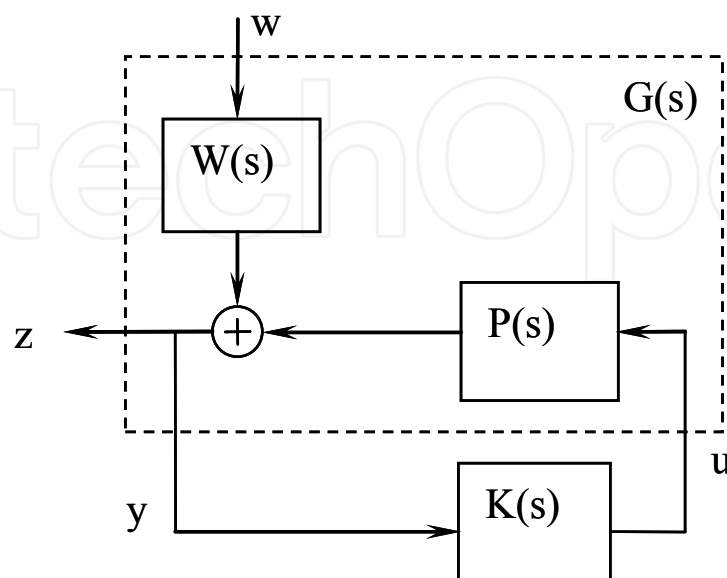

Fig. 1. Nominal Performance Scheme

It can be shown that closed-loop transfer function from w to z can be obtained via lower linear fractional transformation (Zhou & Doyle, 1998).

Therefore H_∞ control problem is to find a stabilizing controller, K , which minimizes

$$\|F_l(P, K)\|_\infty = \sup_{\omega} \bar{\sigma}(F_l(P, K)(j\omega)) = \gamma_M \quad (2)$$

where F_l is the lower linear fractional transformation from w to z and $\bar{\sigma}$ is the singular value of specified transfer function.

For what concerns Nominal Performance Problem, it is required that error z is kept as small as possible. To this end, a new generalized plant can be considered (see the dashed line). The weighting function penalizes the infinite-norm of new plant to achieve required performances.

In the same way, Robust Stability Problem can be solved applying Small Gain Theorem (Zhou & Doyle, 1998) to the following new generalized plant selected (see the dashed line):

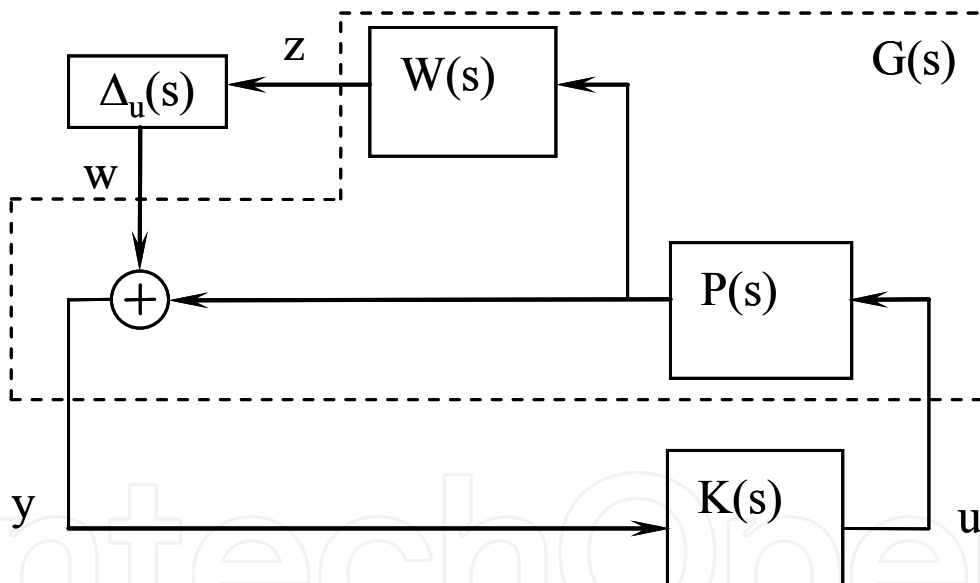

Fig. 2. Robust Stability Scheme

A more general problem to solve is Robust Performance Problem that takes into account both Nominal Performance and Robust Stability Problems. It is worth noting that a Nominal Performance Scheme allows to find a stabilizing controller that satisfies Small Gain Theorem in presence of a fictitious uncertainty block $\Delta_f(s)$ (with $\|\Delta_f(s)\|_\infty < 1/\gamma_M$). Hence a general scheme for Robust Performance Problem is the following one:

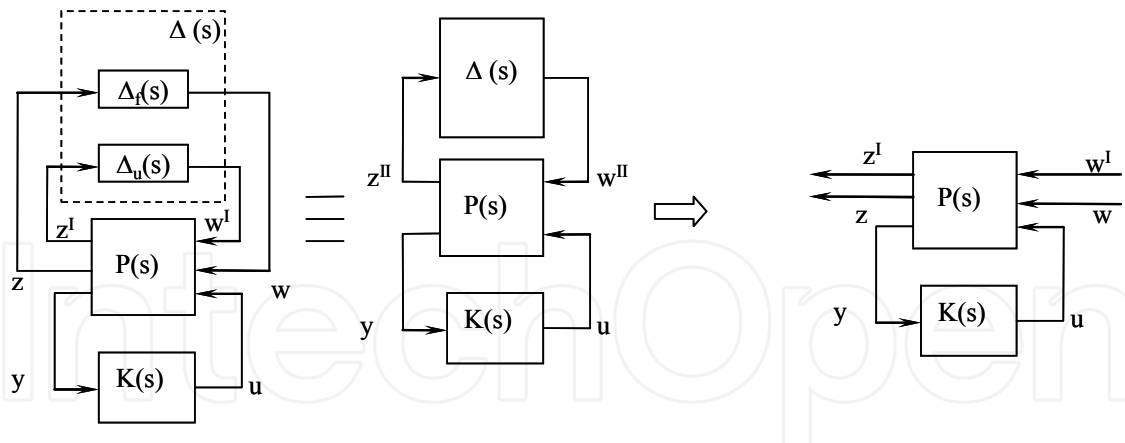

Fig. 3. Robust Performance Scheme

where:

$$\Delta(s) = \begin{bmatrix} \Delta_u(s) & 0 \\ 0 & \Delta_f(s) \end{bmatrix} \tag{3}$$

It is clear from the figures that all above problem formulations can be always rearranged to solve the same general H_∞ problem. It is worth noting that for what concerns Robust Performance Case, $\Delta(s)$ matrix has a diagonal block structure. Plant uncertainties can be structured like mixed (real and complex) uncertainties. Unfortunately H_∞ problem only deals with unstructured full complex $\Delta(s)$, so optimal (or sub-optimal) controller might be very conservative. μ -analysis and synthesis try to solve this issue by dealing with structured uncertainties.

2.2 μ -synthesis framework

The brief discussion of previous paragraph has shown how to design an H_∞ controller starting from a generalized plant. Required performances are achieved through optimal (or sub-optimal) controller by means of weighting functions of a generalized plant. In the same way, robust stability is achieved together with performances by solving Robust Performance Problem. Let $M = F_l(P, K)$, then a general scheme for μ -analysis is the following one:

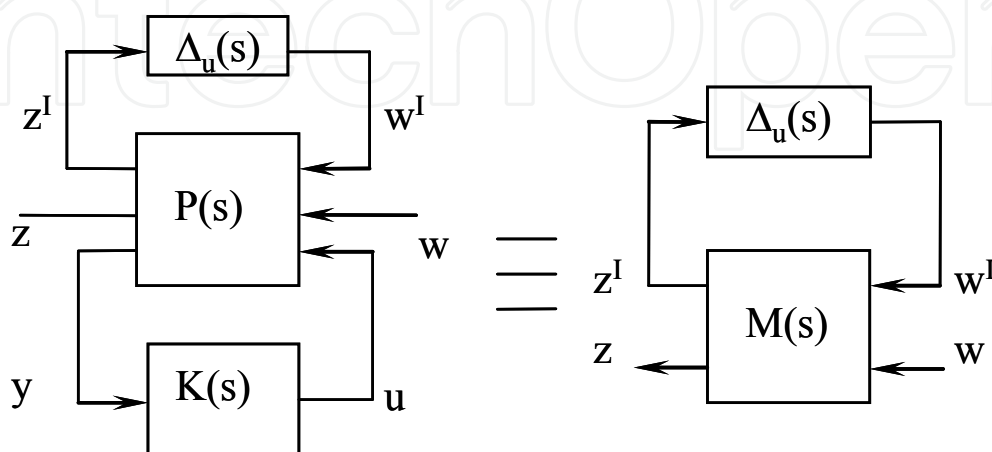

Fig. 4. μ -Analysis Scheme

Introducing structured singular value:

$$\mu_{\Delta}(M) := \frac{1}{\min\{\bar{\sigma}(\Delta) : \det(I - M\Delta) = 0\}} \quad (4)$$

(where Δ_u is the structured uncertainty mentioned earlier), for all $\Delta_u(s)$ with $\|\Delta_u(s)\|_{\infty} < 1/\beta$, and $\beta > 0$, the loop of previous figure is internally stable and $\|F_l(M, \Delta_u)\|_{\infty} < \beta$ if and only if

$$\sup_{\omega \in \mathbb{R}} \mu_{\Delta}(M(j\omega)) \leq \beta \quad (5)$$

Therefore, given a controller $K(s)$, μ -bound β can be numerically computed. Finally μ -synthesis framework can be represented through the following scheme.

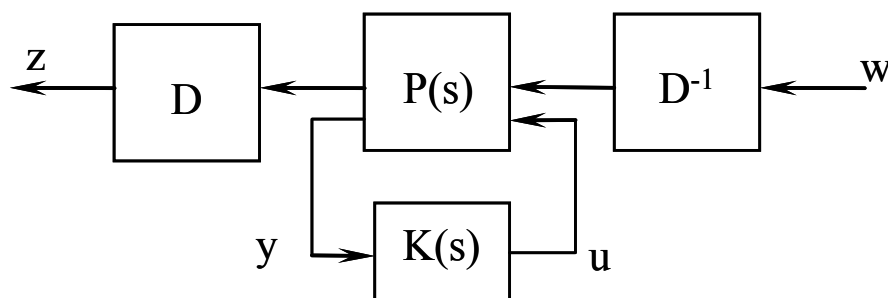

Fig. 5. μ -Synthesis via scaling

where D matrix allows scaling the process taking into account structured uncertainties from z to w . A commonly used methodology to solve the above problem is DK-iterations algorithm (Zhou & Doyle, 1998) that sequentially performs two parameter minimization: first minimizing over K with D fixed, then minimizing over D with K fixed, then again over K , and again over D , etc. The algorithm runs until a fixed bound is achieved and final K is the desired controller.

2.3 Fuzzy scheduling

Each controller developed using the technique described in the previous sections can be considered as a "local" controller, since it might not guarantee the same performances "far away" from design point (or outside a given region of flight envelope). If that region does not cover flight envelope of interest, a controller scheduling is necessary.

Many techniques and methodology have been investigated in literature (Nichols et al., 1993; Pedrycz & Peters, 1997; Hyde & Glover, 1993), but no one guarantees that scheduled controller provides robust performance to be achieved by closed loop system.

In (Pedrycz & Peters, 1997), authors present a general approach to a fuzzy interpolation of different LTI controllers. Although controllers are PID with different gains, the technique can be easily generalized to more complex LTI systems.

For what concerns application of fuzzy scheduling for the proposed DTFT application, a sort of fuzzy gain scheduling technique has been implemented using an approach similar to the one described in (Pedrycz & Peters, 1997).

Considering a system with dynamics described by the following equations:

$$\begin{aligned}\dot{x} &= f(x(t), u(t)) \\ y &= g(x(t), u(t)) \\ x &\in R^n, u \in R^r, y \in R^m\end{aligned}\quad (6)$$

and a family of equilibrium points (x_{ei}, y_{ei}, u_{ei}) , with $i=1, 2, \dots, c$. System linearization leads to the following linear system:

$$\begin{aligned}\dot{\tilde{x}} &= A_i \tilde{x} + B_i \tilde{u} \\ \tilde{y} &= C_i \tilde{x} + D_i \tilde{u}\end{aligned}\quad (7)$$

For each linearized model it is possible to design a local (linear) controller, L_1, L_2, \dots, L_c , on which the overall control laws will be based. Let $\Omega_1, \Omega_2, \dots, \Omega_c$ be fuzzy relations whose activation levels require specific control actions; the computations of control are then regulated by smooth, centre of gravity type of switching:

$$u = \frac{\sum_{i=1}^c L_i \left(y * \frac{\Omega_i(x, u_{ei})}{\sum_{i=1}^c \Omega_i(x, u_{ei})} \right) * \Omega_i(x, u_{ei})}{\sum_{i=1}^c \Omega_i(x, u_{ei})}\quad (8)$$

3. Adaptive control system

Direct Adaptive Model Following (DAMF) is a Model Reference Control Strategy with strong robustness properties obtained through the use of direct adaptation of control loop gains in order to achieve a twofold objective: zero error between output of reference model and output of real plant and furthermore minimization of control effort. The proposed adaptation algorithm is based on Lyapunov theory. Hereinafter a brief mathematical description of the method, fully reported in (Kim et al., 2003), will be given. Starting from generic linear model of a plant:

$$\begin{aligned}\dot{x} &= Ax + Bu + d \\ y &= Cx\end{aligned}\quad (9)$$

where $x \in \mathfrak{R}^n$ is the state vector, $y \in \mathfrak{R}^l$ the output vector, $u \in \mathfrak{R}^m$ the control vector, $A \in \mathfrak{R}^{n \times n}$, $B \in \mathfrak{R}^{n \times m}$, $C \in \mathfrak{R}^{l \times n}$ and the term d represents the trim data, reference system dynamics are written in term of desired input-output behaviour:

$$\dot{y}_m = A_m y_m + B_m r\quad (10)$$

where y_m is the desired output for the plant, r is the reference signal, A_m and B_m represent the reference linear system dynamics. Control laws structure is defined as:

$$u = C_0(G_0x + v + r + K_0y_m) \quad (11)$$

where G_0 , C_0 and v are adaptive control gains, while K_0 is a feed-forward gain matrix off-line computed. It is possible to demonstrate that the following adaptation rules for control laws parameters:

$$\begin{aligned} \dot{G}_0 &= -\gamma_1 B_m^T P e x^T \\ \dot{C}_0 &= -\gamma_2 C_0 B_m^T P e u^T C_0 \\ \dot{v}_0 &= -\gamma_3 B_m^T P e \end{aligned} \quad (12)$$

imply the non-positiveness of Lyapunov candidate function derivative:

$$\dot{V} = -e^T P e \leq 0 \quad (13)$$

which guarantees the asymptotical stability for the error dynamic system (Kim et al., 2003). Matrix P is the solution of Lyapunov equation:

$$A_e^T P + P A_e = -Q; \quad \text{with } Q > 0 \quad (14)$$

With reference to the implementation of adaptive technique for DTFT1 benchmark application, detailed scheme of MIMO controller is reported in Fig. 6. The design parameters of both inner and outer loops consist of a few number of matrices. First of all, Reference Dynamics are expressed by means of two matrices A_m and B_m with limitation that B_m must be chosen invertible. Desired error dynamic is regulated by means of A_e . Through this matrix it is also possible to modify system capability to reject noise and disturbances, thus defining the shape of closed loop system bandwidth. The matrix Q in Eq. (14) is used to specify tracking performance requirements of output variables. Finally, parameters γ_1 , γ_2 and γ_3 are used to regulate the adaptive capability of control gains. Large values imply quick adaptivity and vice versa.

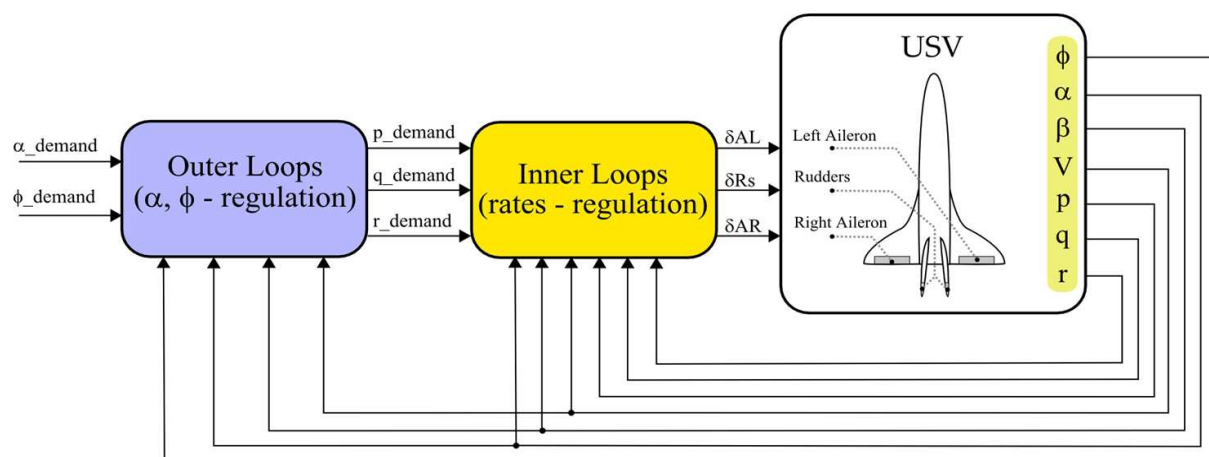

Fig. 6. The general scheme of control system architecture

Control architecture depicted in Fig. 6 is made of two MIMO control loops. The inner one is referred to the rates (p , q , r) regulation, while the outer one is used to control both angle of

attack (α) and roll angle (ϕ). Either MIMO controllers are designed with Adaptive Model Following (AMF) control technique above described.

In the following table a brief description of which variables have been used for the design of both inner and outer loops is given.

	y	x	r	u
<i>inner loops</i>	p, q, r	$v_{TAS}, \alpha, \beta, p, q, r$	$p_{DEM}, q_{DEM}, r_{DEM}$	$\delta_{AL}, \delta_{AR}, \delta_R$
<i>outer loops</i>	α, ϕ	$v_{TAS}, \alpha, \beta, \phi$	α_{DEM}, ϕ_{DEM}	$p_{DEM}, q_{DEM}, r_{DEM}$

Table 1. Controller Variables

4. Probabilistic robust controller

Within the stochastic paradigm for control system design/analysis, the meaning of robustness is moved from its well known deterministic sense to a probabilistic one. Indeed, it is claimed that a certain property of a control system is “almost” robustly satisfied, if it holds for “most” of the occurrences of uncertain variables. In other words, a risk that this property is violated by a set of uncertainties with small probability measure is considered acceptable.

Nevertheless, from a computational point of view, assessing probabilistic robustness of a given property may be more difficult than the deterministic case, since it requires the computation of a multi-dimensional probability integral. This problem is overcome by means of randomized algorithms which estimate performance probability by randomly sampling the uncertainty space, and computing bounds on the estimation error. Since estimated probability is itself a random quantity, this method always entails a certain risk of failure, i.e. there exists a nonzero probability of making an erroneous estimation. These algorithms have low complexity and are associated to robustness bounds which are less conservative than classical ones, obviously at the expense of a non deterministic result.

Randomization can be effectively used for control synthesis, by means of two different approaches. The first one aims at designing controllers that satisfy a given performance specification for most values of uncertainties, i.e. that are robust in a probabilistic sense, while the second one aims at finding a controller that maximizes the mean value of performance index, thus in the latter case the objective is to obtain a controlled system that guarantees the best performance on average (Tempo et al., 2005). For what concerns the use of this technique for DTFT1 benchmark application, the second approach has been used.

The approach used for controller synthesis was to look for a controller that (probabilistically) minimizes the mean value of the performance index, thus the objective was to obtain a controlled system that guarantees the best performance *on average*.

Performance function for the uncertain system is first defined:

$$u(\Delta) : \Delta \rightarrow \mathfrak{R} \quad (15)$$

the above function gives a measure of system performance for a given value of uncertainty Δ . In this application the function u is the following Boolean function which represents the “failure” of a given controller, that is,

$$u(\Delta) = \begin{cases} 1 & \text{if a given system property is not satisfied} \\ 0 & \text{otherwise} \end{cases} \quad (16)$$

Controller C_{opt} will be the one guaranteeing that the expected value of performance function $u(\Delta, C)$ is minimized:

$$C_{prob} = \arg \min_{c \in C} E[u(\Delta, C)] \quad (17)$$

An approximate solution can be obtained by means of randomized algorithms which are based on sampling both uncertainty set Δ and controller set C . To this end, two separate problem need to be solved: first, an estimate of the expected value is computed, then this estimate is minimized.

Computation of $E[u(\Delta, C)]$ is carried out through randomization, that is, M independent, identically distributed (i.i.d.) controllers $C^1, C^2, \dots, C^M \in C$ are extracted according to their probability density function $f_C(C)$; an estimation of the minimum value is then given by:

$$\min_{i=1,2,\dots,M} E[u(\Delta, C^i)] \quad (18)$$

It is possible to demonstrate (Tempo et al., 2005) that, given $\varepsilon_1 \in [0, 1]$, and $\delta \in [0, 1]$, if

$$M \geq \frac{\log \frac{1}{\delta}}{\log \frac{1}{1 - \varepsilon_1}} \quad (19)$$

then:

$$\text{Prob} \left\{ \text{Prob} \left\{ E[u(\Delta, C)] \leq \min_{i=1,2,\dots,M} E[u(\Delta, C^i)] \right\} \leq \varepsilon_1 \right\} \geq 1 - \delta \quad (20)$$

As it can be noticed, computation of $E[u(\Delta, C^i)]$ for each C^i requires the execution of a multidimensional integral, that is very difficult in general; also this problem is solved by randomization approach.

For what concerns estimation of the expected value $E[u(\Delta, C^i)]$ of performance function, N i.i.d. samples $\Delta^1, \Delta^2, \dots, \Delta^N$ are extracted from Δ , according to their density function f_Δ ; performance functions $u(\Delta^1, C^1), \dots, u(\Delta^N, C^1)$ are then computed for a fixed controller $C^i \in C$, and an estimation $\hat{E}_N[u(\Delta, C^i)]$ of the expected value $E[u(\Delta, C^i)]$ is given by:

$$\hat{E}_N[u(\Delta, C^i)] = \frac{1}{N} \sum_{k=1}^N u(\Delta^k, C^i) \quad (21)$$

It can be demonstrated (Tempo et al., 2005) that, if:

$$N \geq \frac{\log \frac{2}{\delta}}{2\varepsilon_2^2} \quad (22)$$

then:

$$\text{Prob}\left\{\left|E\left[u\left(\Delta, C^i\right)\right]-\hat{E}_N\left[u\left(\Delta, C^i\right)\right]\right|\leq \varepsilon\right\} \geq 1-\delta \quad (23)$$

In order to compute a probabilistic controller, equations (20) and (23) must be put together. To this end, it can be shown that, for any $\varepsilon_1, \varepsilon_2 \in [0,1]$ and $\delta \in [0,1]$, if

$$M \geq \frac{\log \frac{1}{\delta}}{\log \frac{1}{1-\varepsilon_1}} \quad \text{and} \quad N \geq \frac{\log \frac{2M}{\delta}}{2\varepsilon_2^2} \quad (24)$$

then

$$\text{Prob}\left\{\text{Prob}\left\{E\left[u\left(\Delta, C\right)\right] \leq \min_{i=1,2,\dots,M} \hat{E}_N\left[u\left(\Delta, C^i\right)\right] - \varepsilon_2\right\} \leq \varepsilon_1\right\} \geq 1 - \frac{\delta}{2} \quad (25)$$

The randomized probabilistic controller is given by:

$$\hat{C}_{NM} = \arg \min_{i=1,\dots,M} \frac{1}{N} \sum_{k=1}^N u\left(\Delta^k, C^i\right) \quad (26)$$

Eq. (25) states that the estimated minimum $\min_{i=1,2,\dots,M} \hat{E}_N\left[u\left(\Delta, C^i\right)\right]$ is “close” to the actual one $E\left[u\left(\Delta, C_{prob}\right)\right]$ within ε_2 in terms of probability, and this is guaranteed with an accuracy ε and a confidence level at least $\delta/2$.

For what concerns the implementation of the above technique to the benchmark application, a fixed control system architecture (inherited from GNC system of DTFT1) has been chosen and its parameters have been optimized according to a stochastic technique. Since controller gains are scheduled with dynamic pressure, controller design have been carried out by optimizing scheduling parameters through stochastic synthesis.

In particular, once the controller structure is defined, stochastic optimization allows selecting the optimum controller parameters also accounting for all the uncertain parameters, mainly vehicle and environment ones. For each candidate vector of control parameters, success rate is computed according to a pre-specified figure of merit and the applied uncertainties. To this end, a first test is performed considering nominal conditions, i.e. no uncertainties applied. If the considered controller passes the test in nominal conditions, uncertainty region is sampled and, for each uncertainty sample, the nonlinear test is repeated and success rate is computed. For this application, the following test success criteria have been used:

- No instability (identified as commands oscillation along the trajectory) occurring during the trajectory.
- No Out-of-Range commands deflection (Max. $\pm 25^\circ$ for the elevons, $\pm 20^\circ$ for the rudder);
- Satisfactory tracking performances for tracked variables (1° RMS in α and β , 3° RMS in ϕ);
- Valid aerodynamic data during the trajectory ($\alpha \in [-5 \div 18^\circ]$, $\beta \in [-8 \div 8^\circ]$).

5. Numerical analysis

In this section the results of a numerical analysis carried out in order to compare performance and robustness of the developed control systems will be presented. The activity has been carried out in the framework of Unmanned Space Vehicle (USV) program of Italian Aerospace Research Centre (CIRA), which is in charge of developing unmanned space Flying Test Beds (FTB) to test advanced technologies during flight. The first USV Dropped Transonic Flight Test (named DTFT1) was accomplished in February 2007 with the first vehicle configuration of USV program (named FTB1) (Russo et al., 2007). In this mission, a conventional control architecture was implemented. DTFT1 was then used as a benchmark application for comparison among different advanced control techniques. This comparison aimed at choosing the most suited control technique to be used for subsequent dropped flight test, named DTFT2, carried out on April 2010.

In the figure below the trajectory of DTFT1 mission in the plane Mach-altitude is depicted.

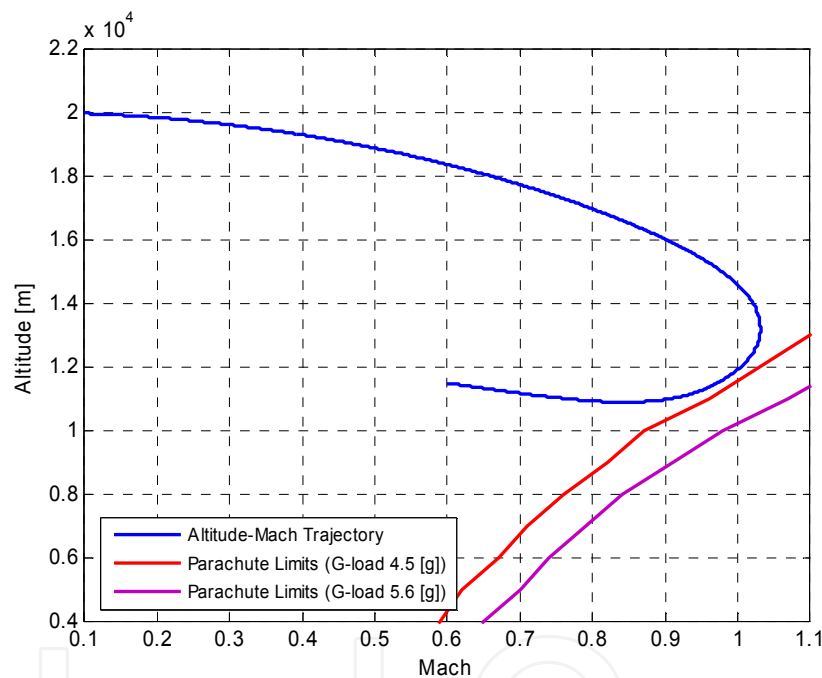

Fig. 7. Mach-Altitude Trajectory

For what concerns control performances, they are specified in the next table and they are valid only for Mach > 0.7 (transonic regime):

Variable Tracked	Tracked Value [deg]	RMS Accuracy [deg]
Angle of Attack	7	1
Angle of Sideslip	0	1
Roll angle	0	3

Table 2. Tracked Variables

In order to compare the advanced controllers described in previous sections, the following scenarios have been identified:

- robustness to parametric uncertainties, namely aerodynamic ones
- robustness to initial state displacement
- robustness to navigation errors (sensor noise)
- robustness to actuator failures

Within this framework, control laws robustness is the capability of guaranteeing performances and stability of control systems in presence of above uncertainties.

Numerical evaluation reported in this section have been carried out using a complete 6 Dof model of FTB1 vehicle together with Atmospheric Model, wind model, Hydraulic Actuator System, Air Data System, Inertial Measurement System and control laws.

Parametric uncertainties have been accounted for by considering a particular aerodynamic configuration (hereafter called the worst configuration) which was identified as the aerodynamic uncertainty configuration leading to worst dynamic behaviour of FTB1 vehicle, in terms of stability, damping and control derivatives that mainly affect stability properties.

Two test cases, named C_0 , and \hat{C}_0 , have been accomplished with both nominal conditions (nominal initial state, zero navigation errors, no failure, etc.) and worst aerodynamic configuration respectively.

For what concerns robustness to initial state displacement, several off-nominal conditions in terms of Euler angles and angular rates have been considered (see the following table). Nominal DTFT1 initial state in terms of attitude, heading and angular rates is: $\phi_0 = 0$ deg, $\theta_0 = -90$ deg, $\psi = 0$ deg, $p = 0$ deg/s, $q = 0$ deg/s, $r = 0$ deg/s.

Initial State Displacement	ϕ_0 [deg]	θ_0 [deg]	ψ_0 [deg]	p_0 [deg/s]	q_0 [deg/s]	r_0 [deg/s]
I_1	-20	-89.9	0	-5	3	-3
I_2	20	-89.9	0	2	2	-2
I_3	20	-89.9	0	5	2	1
I_4	0	-85	0	-5	2	0

Table 3. Initial State Displacement

Furthermore for each case of the above table, nominal (case $C_1 - C_4$) and worst aerodynamic configuration (case $C_5 - C_8$) have been simulated.

For what concerns navigation errors, simulations have been performed with both nominal (case C_9) and worst aerodynamic configuration (case C_{10}) without any initial state displacement.

As far as robustness to actuator failures is concerned, a rudder failure occurring after 30 s from vehicle's drop has been simulated, in particular a jam of the right rudder. It is worth noting that in this case (C_{11}) both initial state and aerodynamic configuration are nominal. All the benchmark scenarios are summarized in the following table.

Case	Aerodynamic Configuration	Initial State	Navigation Errors	Actuator Failure
C_0	Nominal	Nominal	No errors	No failure
\hat{C}_0	Worst-Aero 1	Nominal	No errors	No failure
C_1	Nominal	Off-nominal I_1	No errors	No failure
C_2	Nominal	Off-nominal I_2	No errors	No failure
C_3	Nominal	Off-nominal I_3	No errors	No failure
C_4	Nominal	Off-nominal I_4	No errors	No failure
C_5	Worst-Aero	Off-nominal I_1	No errors	No failure
C_6	Worst-Aero	Off-nominal I_2	No errors	No failure
C_7	Worst-Aero	Off-nominal I_3	No errors	No failure
C_8	Worst-Aero	Off-nominal I_4	No errors	No failure
C_9	Nominal	Nominal	Errors	No failure
C_{10}	Worst-Aero	Nominal	Errors	No failure
C_{11}	Nominal	Nominal	No errors	Right Rudder jamming at 30 s

Table 4. Benchmark Scenarios for Performance Evaluation

For what concerns robust performance indicators, tracking accuracy of trajectory has been defined as a performance parameter. Performance requirements are given in the table below:

Variable Tracked	RMS Tracking error [deg]
Angle of Attack	± 1
Angle of Sideslip	± 1
Roll angle	± 3

Table 5. Tracking Performance requirements

In the next figures the results of scenarios C_0 and \hat{C}_0 are reported.

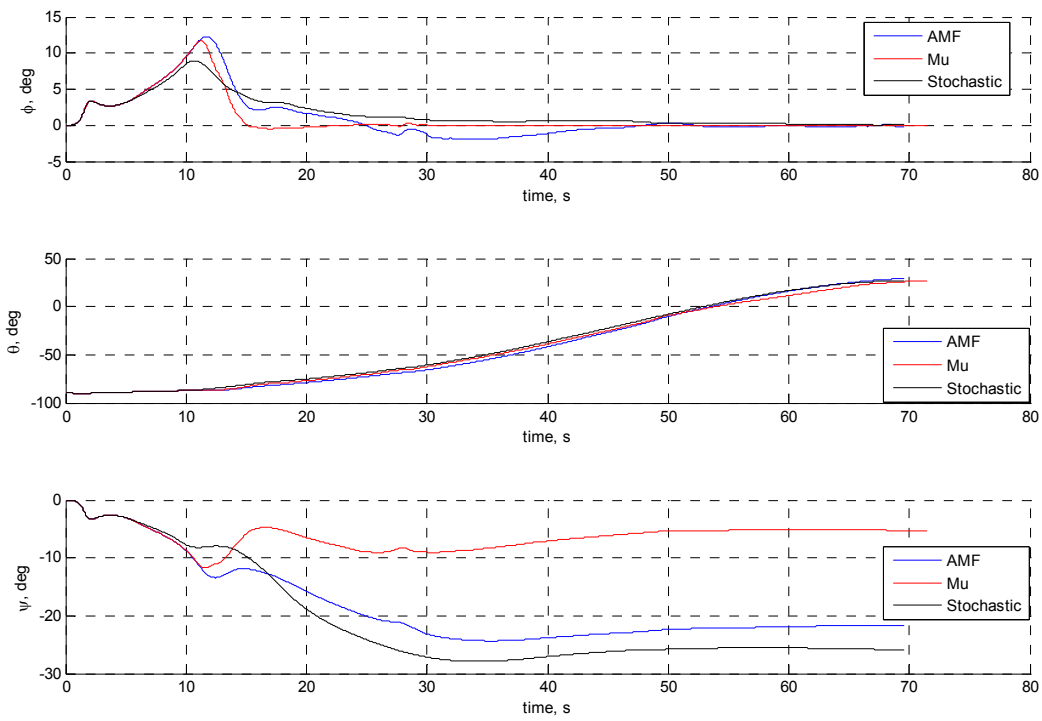

Fig. 8. Case C_0 -Euler Angles

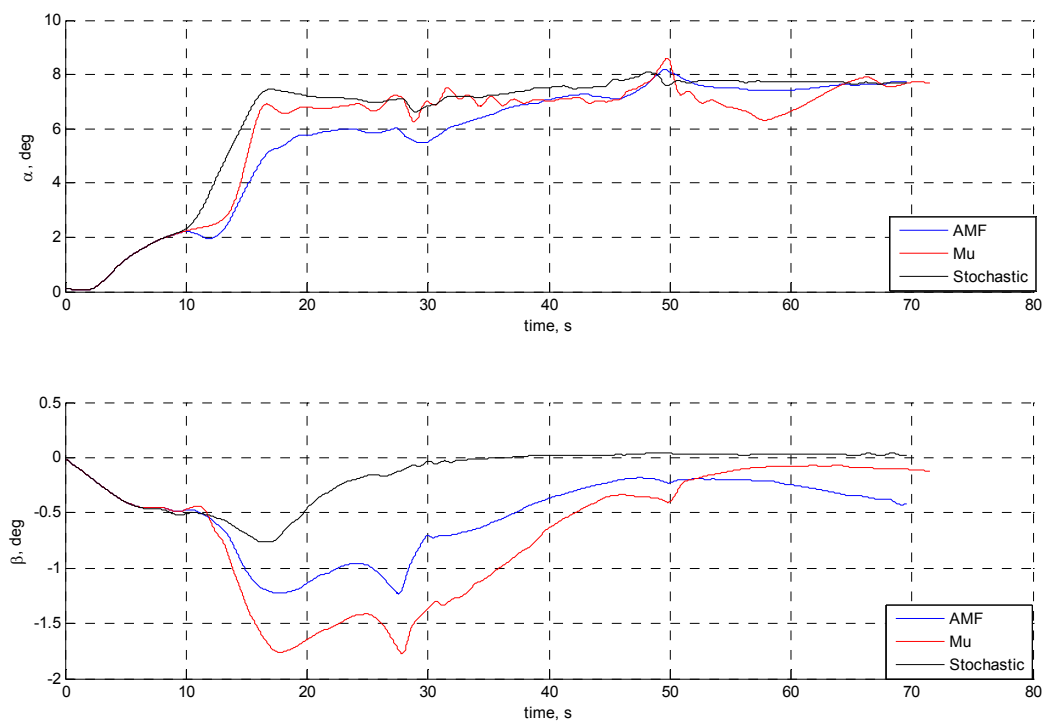

Fig. 9. Case C_0 -Incidence Angles

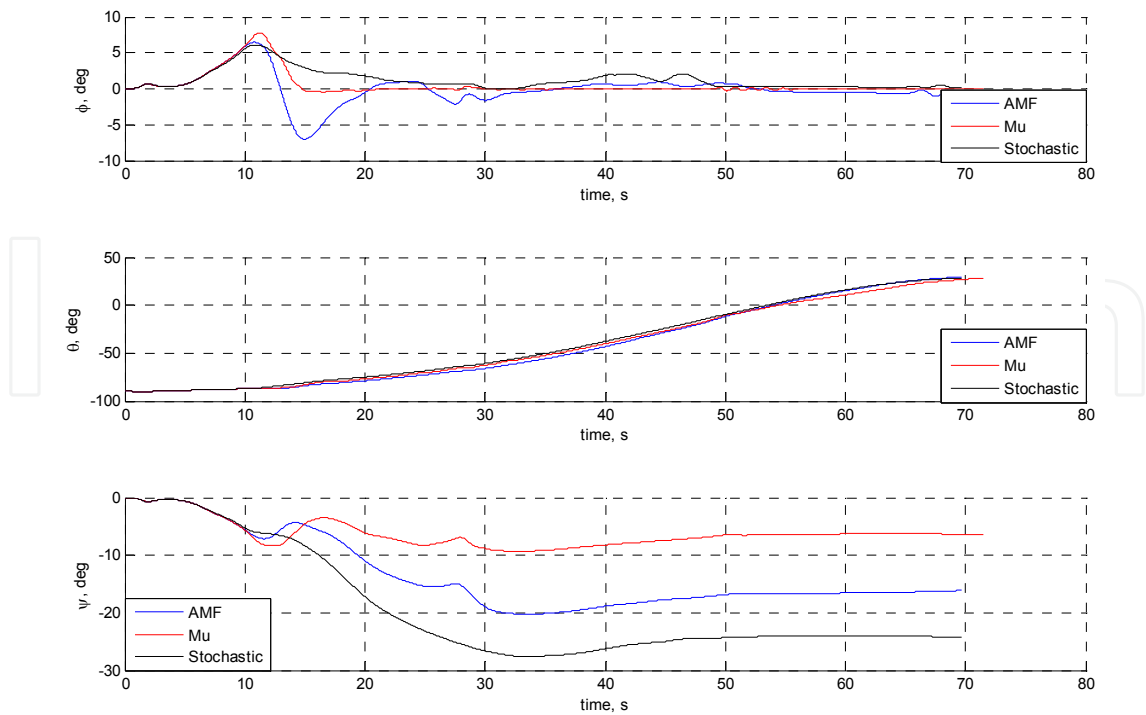

Fig. 10. Case \hat{C}_0 -Euler Angles

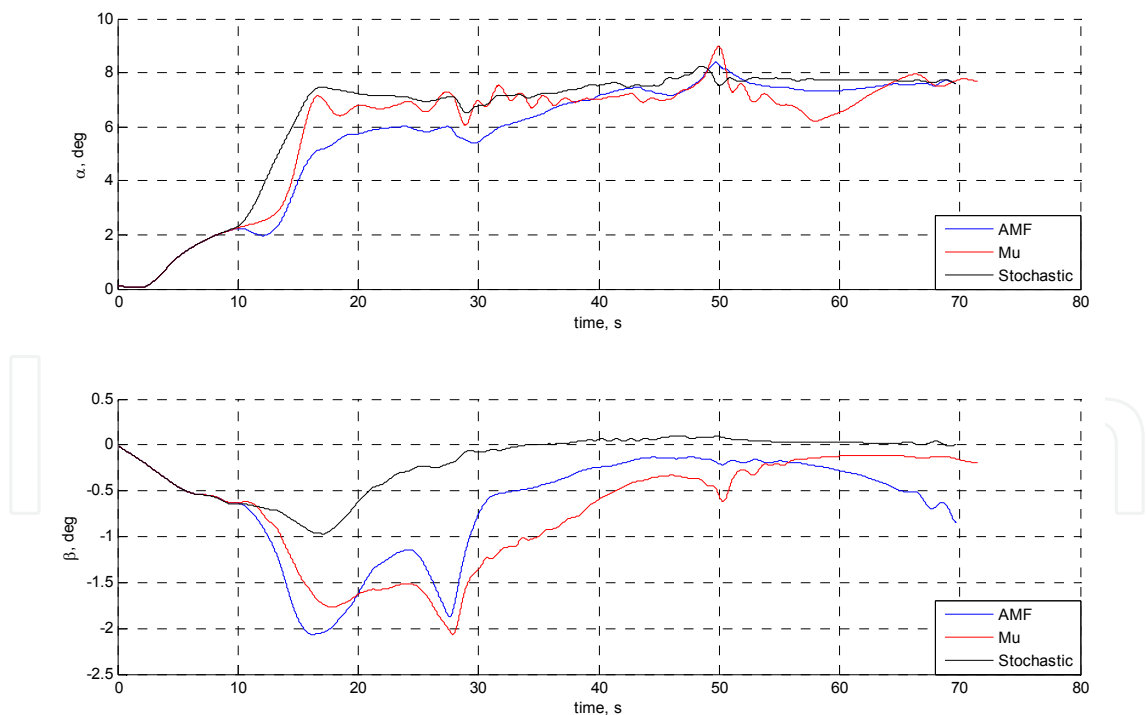

Fig. 11. Case \hat{C}_0 -Incidence Angles

As it can be seen from the figures, performances of all control algorithms are globally satisfactory. It is worth noting that Mu-controller shows a light unstable behaviour on sideslip angle around 50 s in worst case configuration, but it is however rapidly damped in

few seconds. For what concerns uncertainties to initial state displacement, several cases have been considered with different attitude and angular velocity at vehicle drop. In the following figures, for sake of brevity, only the cases C_5 and C_8 are reported. They refer to initial state conditions I_1 and I_4 with worst aerodynamic configuration (see Table 4).

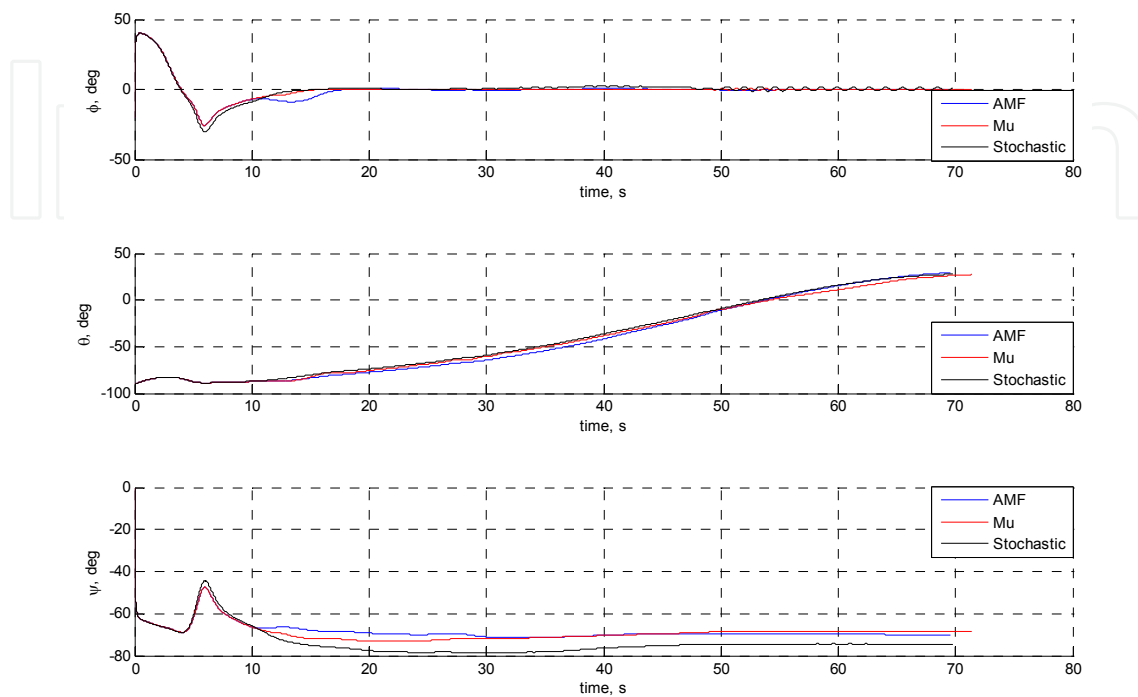

Fig. 12. Case C_5 -Euler Angles

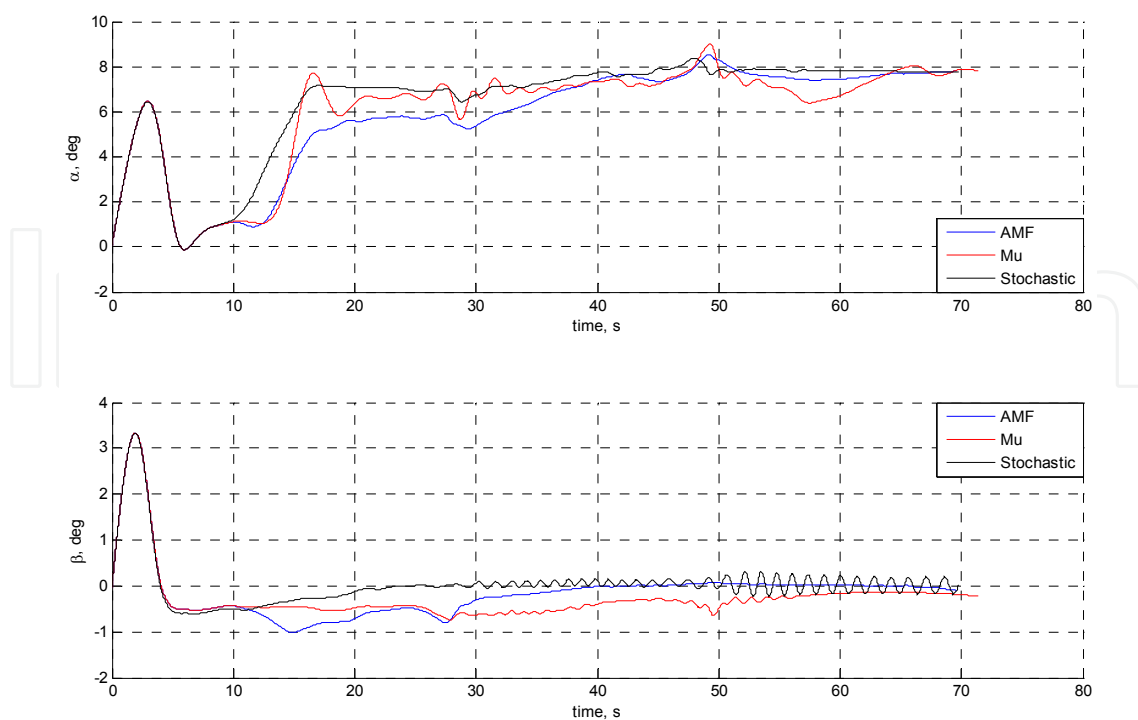
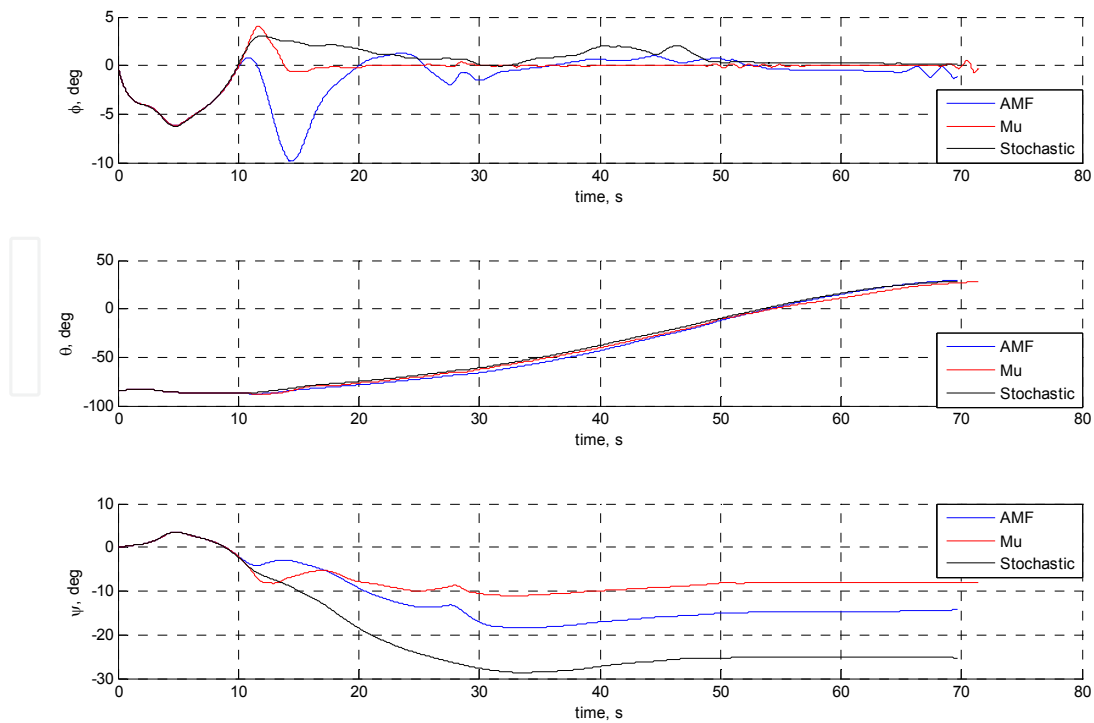
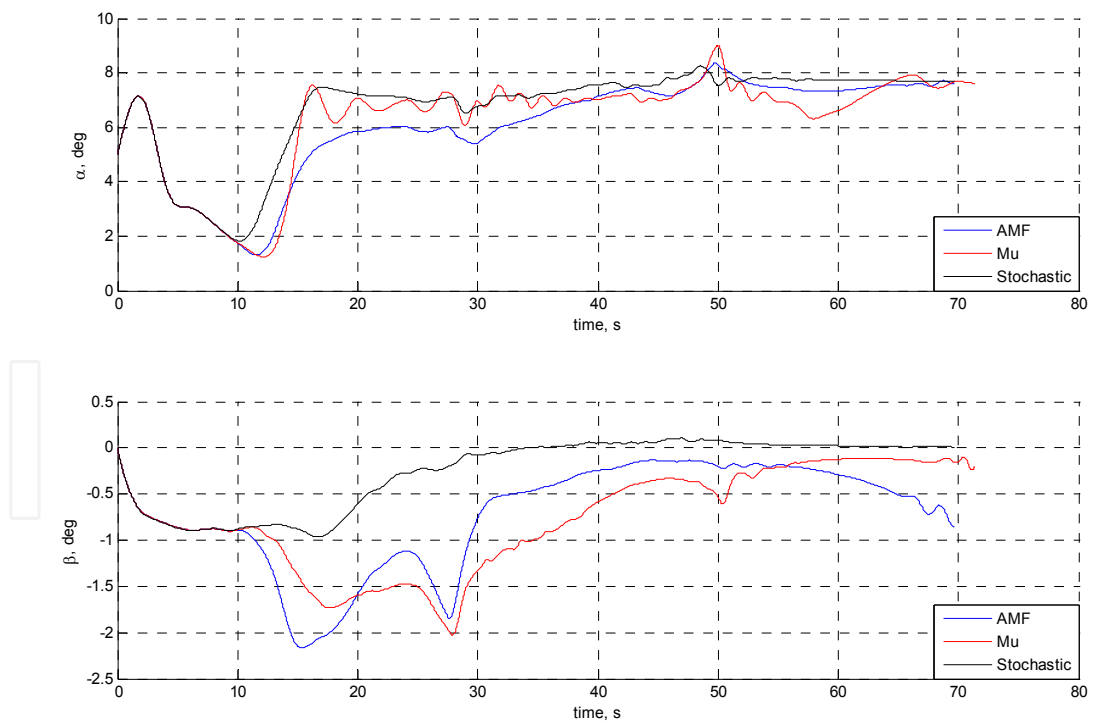

Fig. 13. Case C_5 -Incidence Angles

Fig. 14. Case C_8 -Euler AnglesFig. 15. Case C_8 -Incidence Angles

All controllers satisfactory work in presence of initial state displacement. In spite of a light oscillatory mode on sideslip and roll angles, stochastic controller guarantees very good performances for what concerns tracking of sideslip angle and angle of attack.

As mentioned earlier, in order to evaluate control algorithms capabilities to face disturbances such as navigation errors, two test cases have been considered, i.e. nominal and worst aerodynamic configuration (cases C_9 and C_{10}) without any initial state displacement. The comparison between controllers is reported in the following figure, only with reference to the case C_{10} for sake of simplicity.

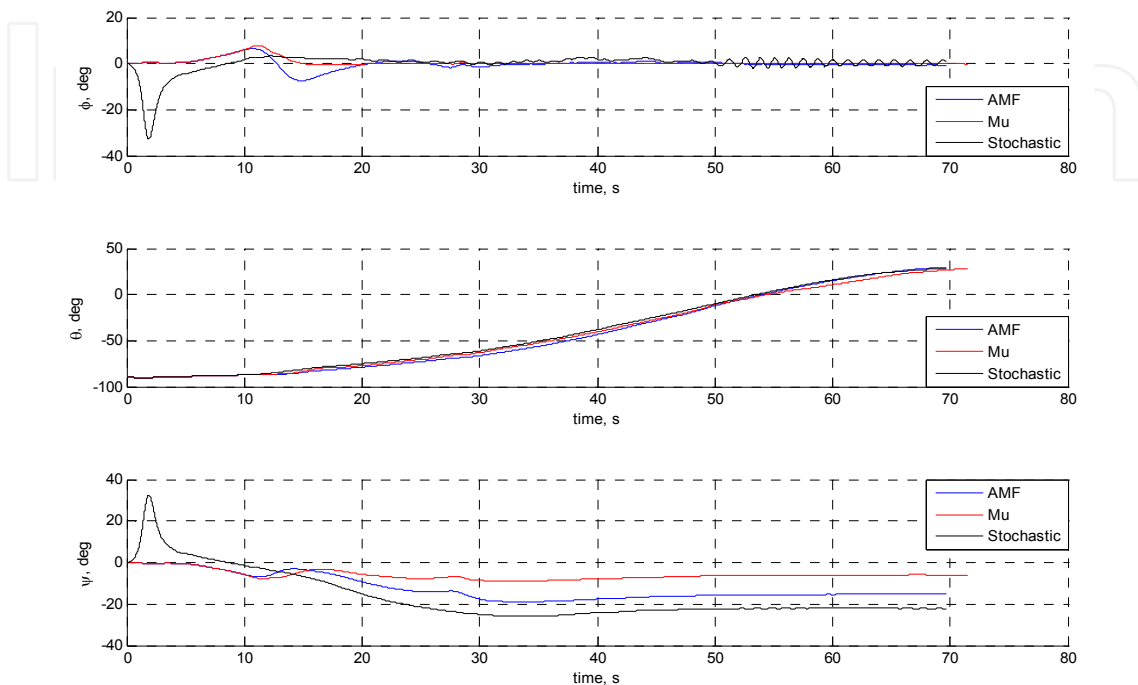

Fig. 16. Case C_{10} -Euler Angles

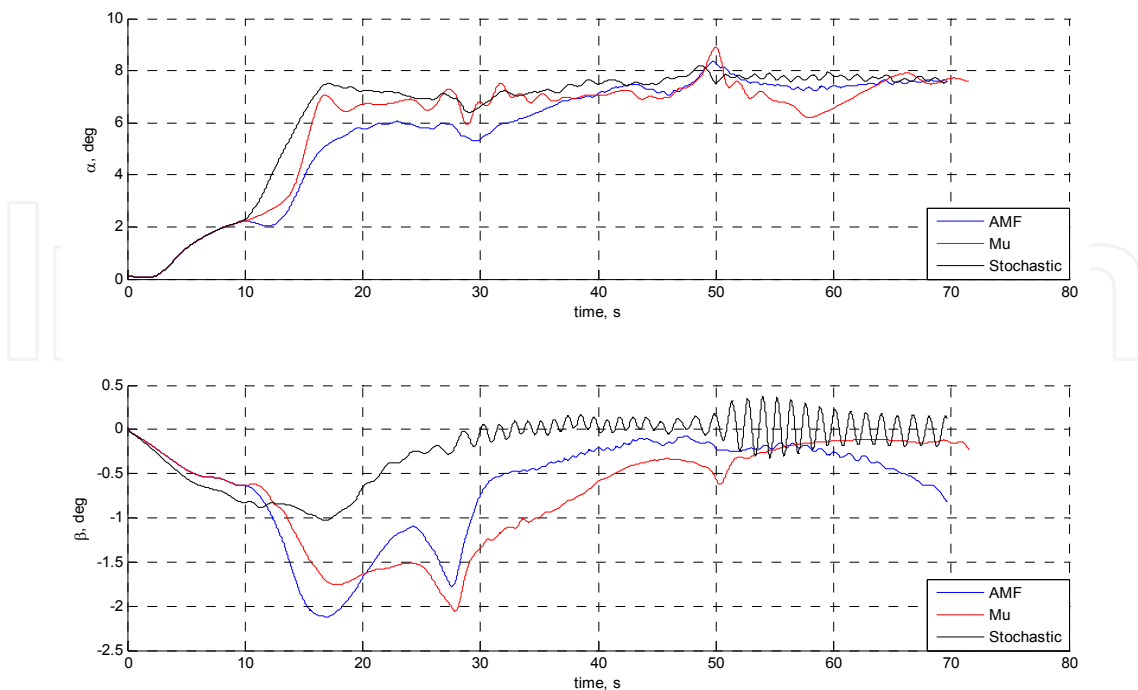

Fig. 17. Case C_{10} -Incidence Angles

Simulations show an acceptable robustness to sensor noise. A small effect on incidence angles, in terms of reduced damping, is shown by stochastic controller.

Finally algorithms robustness to an actuator failure has been evaluated. In particular a rudder jamming at $t=30$ s has been simulated.

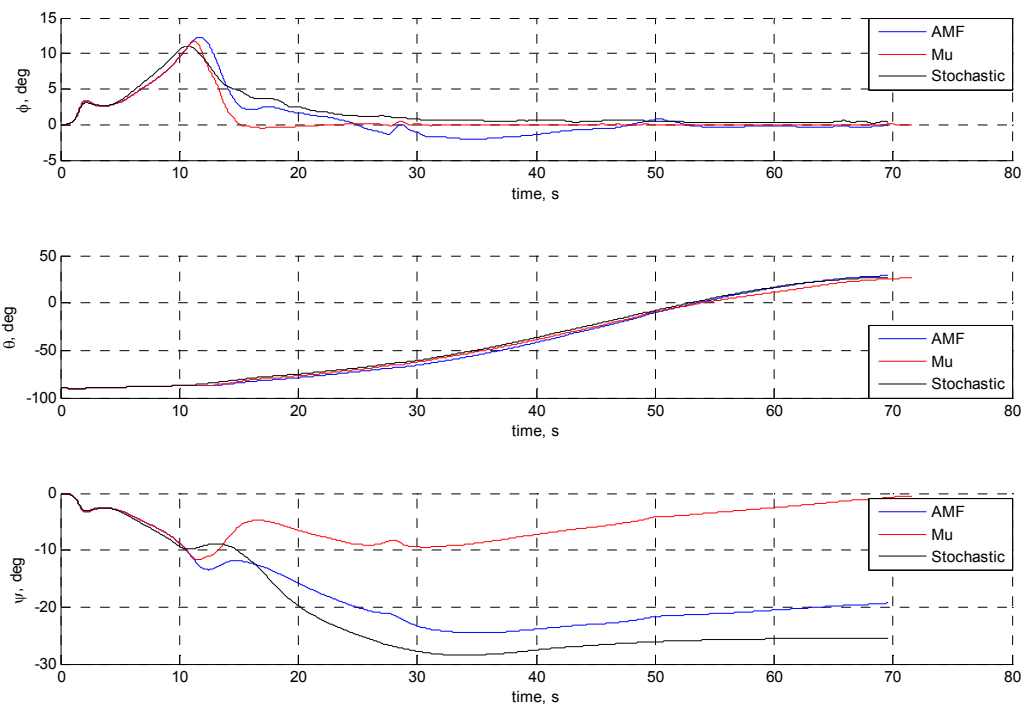

Fig. 18. Case C_{11} -Euler Angles

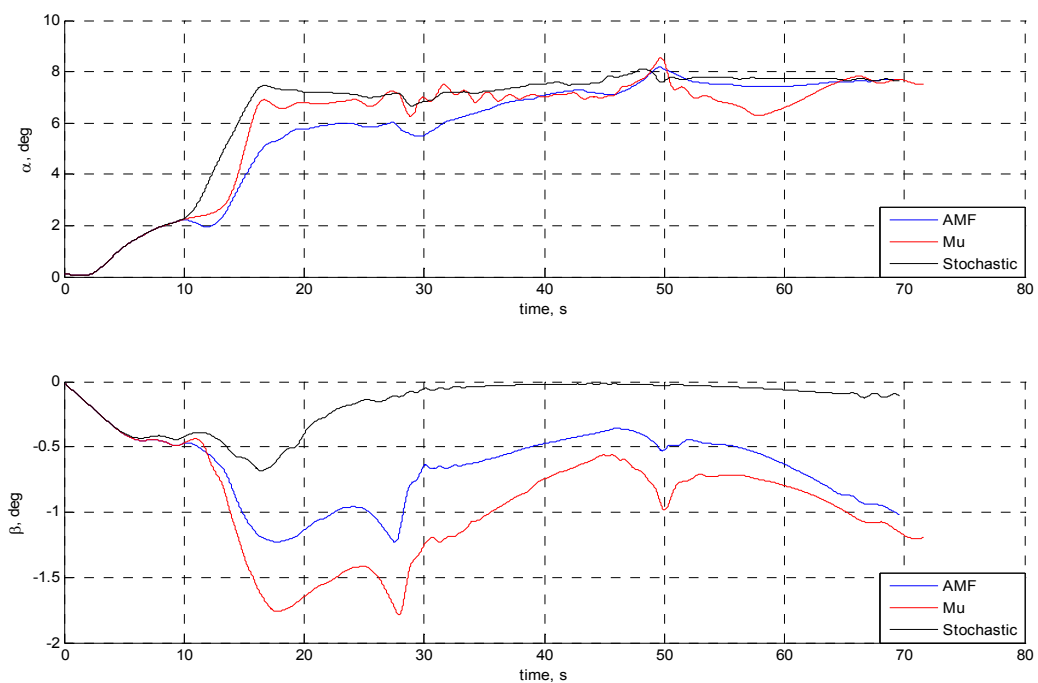

Fig. 19. Case C_{11} -Incidence Angles

The above figures show that rudder jam failure is well tolerated by all the controllers. The following table summarizes the performances achieved by the controllers for all considered scenarios.

Case	Adaptive Controller AoA-AoS-Phi accuracy [deg]	MU-Controller AoA-AoS-Phi accuracy [deg]	Stochastic Controller AoA-AoS-Phi accuracy [deg]
C_0	0.87676	0.57129	0.21606
	0.5969	0.88441	0.13512
	0.72448	0.053638	0.61134
\hat{C}_0	0.90016	0.62284	0.24501
	0.74635	0.91081	0.18806
	0.59708	0.067061	0.8251
C_1	0.88835	0.5642	0.21624
	0.26603	0.63046	0.066145
	0.45265	0.061391	0.42644
C_2	0.88043	0.57188	0.21585
	0.58375	0.97939	0.14444
	0.75665	0.089979	0.64976
C_3	0.87282	0.57878	0.21536
	0.62874	0.83847	0.13685
	0.71016	0.038177	0.63915
C_4	0.86873	0.53892	0.21588
	0.593	0.87025	0.13086
	0.71128	0.05387	0.59952
C_5	0.91649	0.62481	0.2452
	0.29559	0.40438	0.1115
	0.35717	0.14435	1.1254
C_6	0.91255	0.62265	0.24415
	0.75401	1.0448	0.20172
	0.69885	0.13026	0.82289
C_7	0.89565	0.6301	0.24409
	0.73756	0.84141	0.18635
	0.66584	0.044825	0.76552
C_8	0.8919	0.59116	0.24443
	0.74122	0.89455	0.18392
	0.59849	0.10033	0.82521
C_9	0.87611	0.57183	0.22299
	0.60085	0.88728	0.15436
	0.7007	0.053653	0.61589
C_{10}	0.90059	0.62011	0.25904
	0.74182	0.91444	0.23867
	0.57556	0.061636	1.2075
C_{11}	0.8759	0.57115	0.20854
	0.72793	1.0664	0.12598
	0.80693	0.066715	0.65093

Table 6. Controller Performances

The comparison between the controllers has shown that:

1. Stochastic controller guarantees the best performances for what concerns the tracking of AoA and AoS and it always meets performance requirements. Anyway, it presents some light oscillations on lateral and directional dynamics in worst aerodynamic configuration.
2. μ -controller guarantees the best tracking performance in terms of roll angle, much better than required (3 deg error), but in some cases it fails to meet performance requirements on AoA and AoS (see C_6 and C_{11}).
3. Adaptive Controller guarantees almost good tracking performances even though they are never better than the other two controllers. In any case, performance requirements are always met.

Based on the above considerations, the controller obtained by means of stochastic synthesis was considered the most suited for the DTFT2 scopes, so it was selected (after a fine tuning) as a part of an advanced GNC system for DTFT2 mission, successfully carried out on April 2010.

In fact, despite the limitation of using an 'a priori' fixed control structure, control laws obtained through the stochastic synthesis have the following good features:

- excellent performances and good stability properties in spite of large uncertainties affecting the system;
- simple control structures while guaranteeing robust performances and stability as well as low computational effort and implementation simplicity.

6. Conclusions

Over the last decades many efforts have been spent to develop advanced control techniques for aerospace applications, aimed at overcoming limitations of commonly used control techniques, mainly lack of robustness against various uncertainties affecting the system to be controlled. The importance of a robust control system is readily understood when space reentry applications are considered. Indeed, these applications have some distinctive features, mainly related to the lack of stationary equilibrium conditions along the trajectories, to the wide flight envelope characterizing the missions (from hypersonic flight regime to subsonic one) and to the high level of uncertainty in the knowledge of vehicle aerodynamic parameters.

The development of an advanced control system having robustness capabilities is one of the goals of research activities carried out by Italian Aerospace Research Centre in the framework of USV program. In order to select a control strategy having the advantages above discussed, three candidate control techniques have been compared with the aim of selecting the most suited one for the second dropped flight test of USV program, named DTFT2, successfully carried out on April 2010. The three techniques are:

- μ -Controller with Fuzzy Logic Gain-Scheduling
- Direct Adaptive Model Following Control
- Probabilistic Robust Control Synthesis

In order to evaluate the robustness capabilities of proposed control algorithms, a numerical robustness analysis has been performed. Performances and stability of candidate control techniques have been evaluated in presence of several sources of uncertainties (aerodynamics, initial state, etc.) and failure scenarios.

Robustness analysis showed that all three techniques are well suited to accomplish robust control in USV DTFT1 mission, in presence of large parameters uncertainty (the vehicle mostly flies in transonic regime, where accurate aerodynamic prediction is very difficult to obtain).

Nevertheless the controller obtained by means of stochastic synthesis was selected as a part of on-board advanced GNC system for DTFT2 mission, due to its good performances and relatively simple implementation.

7. References

- Ashari E. A. et al. (2005), Reconfigurable control system design using eigenstructure assignment: static, dynamic and robust approaches; *International Journal of Control*, vol. 78, No. 13, 10 September 2005, 1005-1016
- Balas Gary J. (2005), Application of Robust Multivariable Control to Stability, Control Augmentation and Trajectory Tracking of Unmanned Space and Aerial Vehicle, CIRA Short course, 14-18 November 2005
- Bharadwaj, S. Rao, Anil V., and Mease, Kenneth D. (1998), Entry Trajectory Tracking Law via Feedback Linearization, *Journal of Guidance, Control, and Dynamics*, Vol. 21, No. 5, September–October 1998
- Bodson M., Groszkiewicz J.E. (1997), Multivariable Adaptive Algorithms for Reconfigurable Flight Control; *IEEE Transactions on Control Systems Technology*, vol. 5, No. 2, March 1997.
- Calafiore G., Dabbene F., Tempo R. (2007), A survey of randomized algorithms for control synthesis and performance verification, *Journal of Complexity* 23 (2007), pp. 301-316
- Hyde, A., Glover K. (1993), The Application of Scheduled H_∞ Controllers to a VSTOL Aircraft, *IEEE Transaction on Automatic Control*, VOL. 38, NO. 7, July 1993. 1021-1039
- Kim K., Lee K., Kim Y. (2003), Reconfigurable Flight Control System Design Using Direct Adaptive Method, *Journal of Guidance, Control, and Dynamics*, Vol. 26, N° 4, July-August 2003
- Konstantopoulos K., Antsaklis P. (1996), Eigenstructure Assignment in Reconfigurable Control Systems, Technical Report of the ISIS group at the University of Notre Dame, ISIS-96-001, January, 1996
- Liu, G. P. and Patton, R. J. (1996), Robust Parametric Eigenstructure Assignment, AIAA-96-3908
- Malloy, D., and Chang, B.C. (1998), Stabilizing Controller Design for Linear Parameter-Varying Systems Using Parameter Feedback, *Journal of Guidance, Control, and Dynamics*, Vol. 21, No. 6, November–December 1998
- Marcos, A., and Balas, Gary J. (2004), Development of Linear Parameter Varying Models for Aircraft, *Journal of Guidance, Control, and Dynamics*, Vol. 27, No. 2, March 2004
- Nichols, A., Reichert, R. T., W. J. Rugh (1993), Gain Scheduling for H-infinity Controllers: A Flight Control Example, *IEEE Transactions on Control Systems Technology*, Vol. 1, No. 2, June 1993.
- Pedrycz, W., Peters J. F. (1997), Hierarchical Fuzzy Controllers: Fuzzy Gain Scheduling, *IEEE Intern. Conf. on SMC[C]*, 1997.1139-1143

- Rollins L. (1999), *Robust Control Theory*, Carnegie Mellon University, 18-849b Dependable Embedded Systems, Spring 1999
- Russo, G., et al. (2007), *Unmanned Space Vehicle Program: DTFT in Flight Experiments*, 18th ESA Symposium on European Rocket and Balloon Programmes and Related Research, Visby, Sweden, 2007.
- Spillman, Mark S. (2000), *Robust Longitudinal Flight Control Design Using Linear Parameter-Varying Feedback*, *Journal of Guidance, Control, and Dynamics*, Vol. 23, No. 1, January–February 2000
- Tempo R. and Dabbene F. (1999), *Probabilistic Robustness Analysis and Design of Uncertain Systems*, in *Dynamical Systems Control, Coding, Computer Vision – New Trends, Interfaces, and Interplay*, ed. by Picci G. and Gilliam D.S., Birkhauser Verlag, 1999
- Tempo, R., Calafiore, G., Dabbene, F. (2005), *Randomized Algorithms for Analysis and Control of Uncertain Systems*; New York: Springer-Verlag, 2005.
- Van Soest, W. R., Chu, Q. P. and Mulder, J. A. (2006), *Combined Feedback Linearization and Constrained Model Predictive Control for Entry Flight*, *Journal of Guidance, Control, and Dynamics*, Vol. 29, No. 2, March–April 2006
- Vincent, James H., Abbas Emami-Naeinjt and Nasser M. Khraishi (1994), *Case Study Comparison of Linear Quadratic Regulator and H_∞ Control Synthesis*, *Journal Of Guidance, Control, And Dynamics*, Vol. 17, No. 5, September-October 1994
- Xing, L. (2003), *Comparison of Pole Assignment & LQR Design Methods for Multivariable Control for STATCOM*, Thesis submitted to the Department of Mechanical Engineering, Florida State University
- Zhou , K., and Doyle, John C. (1998), *Essential Of Robust Control*, Prentice Hal, 1998

IntechOpen

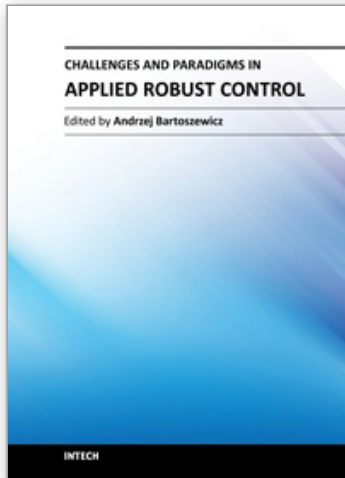

Challenges and Paradigms in Applied Robust Control

Edited by Prof. Andrzej Bartoszewicz

ISBN 978-953-307-338-5

Hard cover, 460 pages

Publisher InTech

Published online 16, November, 2011

Published in print edition November, 2011

The main objective of this book is to present important challenges and paradigms in the field of applied robust control design and implementation. Book contains a broad range of well worked out, recent application studies which include but are not limited to H-infinity, sliding mode, robust PID and fault tolerant based control systems. The contributions enrich the current state of the art, and encourage new applications of robust control techniques in various engineering and non-engineering systems.

How to reference

In order to correctly reference this scholarly work, feel free to copy and paste the following:

Gianfranco Morani, Giovanni Cuciniello, Federico Corraro and Adolfo Sollazzo (2011). Advanced Control Techniques for the Transonic Phase of a Re-Entry Flight, Challenges and Paradigms in Applied Robust Control, Prof. Andrzej Bartoszewicz (Ed.), ISBN: 978-953-307-338-5, InTech, Available from: <http://www.intechopen.com/books/challenges-and-paradigms-in-applied-robust-control/advanced-control-techniques-for-the-transonic-phase-of-a-re-entry-flight>

INTECH
open science | open minds

InTech Europe

University Campus STeP Ri
Slavka Krautzeka 83/A
51000 Rijeka, Croatia
Phone: +385 (51) 770 447
Fax: +385 (51) 686 166
www.intechopen.com

InTech China

Unit 405, Office Block, Hotel Equatorial Shanghai
No.65, Yan An Road (West), Shanghai, 200040, China
中国上海市延安西路65号上海国际贵都大饭店办公楼405单元
Phone: +86-21-62489820
Fax: +86-21-62489821

© 2011 The Author(s). Licensee IntechOpen. This is an open access article distributed under the terms of the [Creative Commons Attribution 3.0 License](#), which permits unrestricted use, distribution, and reproduction in any medium, provided the original work is properly cited.

IntechOpen

IntechOpen