

# We are IntechOpen, the world's leading publisher of Open Access books Built by scientists, for scientists

5,200

Open access books available

128,000

International authors and editors

150M

Downloads

Our authors are among the

154

Countries delivered to

TOP 1%

most cited scientists

12.2%

Contributors from top 500 universities



WEB OF SCIENCE™

Selection of our books indexed in the Book Citation Index  
in Web of Science™ Core Collection (BKCI)

Interested in publishing with us?  
Contact [book.department@intechopen.com](mailto:book.department@intechopen.com)

Numbers displayed above are based on latest data collected.  
For more information visit [www.intechopen.com](http://www.intechopen.com)



# Integrated Mechatronic Design for Servo Mechanical Systems

Chin-Yin Chen<sup>1</sup>, I-Ming Chen<sup>2</sup> and Chi-Cheng Cheng<sup>3</sup>

<sup>1</sup>Taiwan Ocean Research Institute, National Applied Research Laboratories, Kaohsiung, Taiwan R.O.C.

<sup>2</sup>School of Mechanical & Aerospace Engineering, Nanyang Technological University, Singapore

<sup>3</sup>Department of Mechanical and Electro-Mechanical Engineering, National Sun Yat-Sen University, Kaohsiung, Taiwan R.O.C.

<sup>1,3</sup>Taiwan

<sup>2</sup>Singapore

## 1. Introduction

Mechatronic systems typically exhibited high a degree of complexity due to the strong cross coupling of the involved different engineering disciplines such as mechanical, electronic and computer. This complexity originates from the large number of couplings on various levels of the contributing elements and components, coming from different disciplines. The difficulty for the design engineer in his daily work is that these couplings have to be considered in an early phase of the design process. With shortening product lift cycle, design managers are consistently trying to identify means for producing a better product in a shorter period of time.

Therefore, the realm of Mechatronics is high speed, high precision, high efficiency, highly robust. The difficulty in the Mechatronic approach is that it requires a system perspective: system interactions are important, system modeling is required, and feedback control systems can go unstable. Mechatronic design concepts include direct-drive mechanisms, simple mechanics, system complexity, accuracy and speed from controls, efficiency and reliability from electronics, and functionality from microcomputers. Starting at design and continuing through manufacture, Mechatronic designs optimize the available mix of technologies to produce quality precision products and systems in a timely manner with features the customer wants. The real benefits to industry of a Mechatronic approach to design are shorter development cycles, lower costs, and increased quality, reliability, and performance [25].

Additionally, in order to evaluate concepts generated during the design process, without building and testing each one, the mechatronics engineer must be skilled in the modeling, analysis, and control of dynamic systems and understand the key issues in hardware implementation. Thus, as the Fig. 1 shows, the essential characteristic of a mechatronics engineer and the key to success in mechatronics system is a balance between two sets of skills [22]:

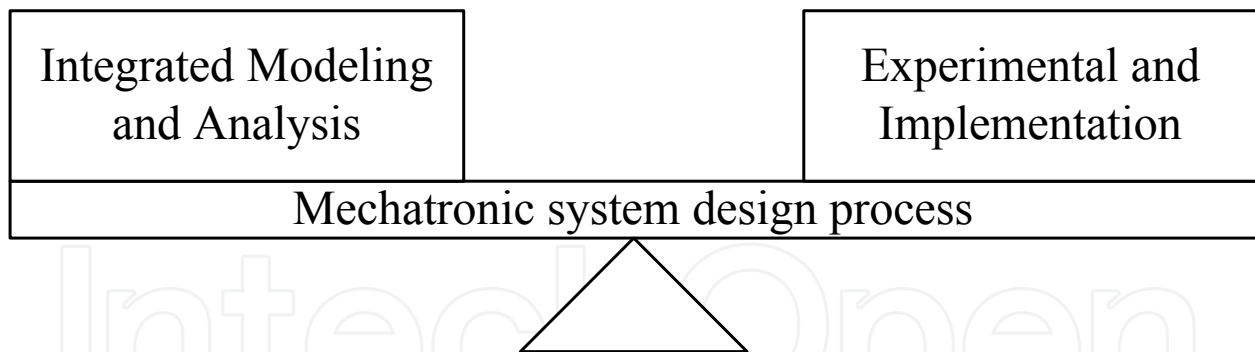

Fig. 1. Balance of mechatronic design process [22].

### 1.1 Integrated modeling and analysis of dynamic mechatronic systems

During the design of mechatronic systems, it is important that changes in the mechanical structure and the controller be evaluated simultaneously [24]. Although a proper controller enables building a cheaper mechatronic system, a badly designed mechanical system will never be able to give a good performance by adding a sophisticated controller. Therefore, it is important that during an early stage of the design a proper choice can be made with respect to the mechanical properties needed to achieve a good performance of the controlled system. On the other hand, knowledge about the abilities of the controller to compensate for mechanic imperfections may enable that a cheaper mechanical structure be built. This requires that in an early stage of the design a simple integrated model is available, that reveals the performance limiting factors of the mechatronic system.

Consequently, in order to help mechanical structure and controller of mechatronic system modeling simultaneously, the mechatronic system design methods must be integration. Accordingly, some of numerical based integrated design strategies for mechatronic system were proposed to some fields such as: aerospace [1-3], robotics [4-6] and manufacturing systems [7-8] in the early years. However, the dynamic models derived with the above integrated methods typically have a high order. A critical issue in the mechanical structure and control modeling with the integrated design approach is difficulty from each domain.

Therefore, for complex multibody systems of mechatronics, graphical modeling software is helpful to formulate automatically the equations of motion from a high-level description. Among the computer modeling methods, symbolic methods allow to build the equations of motion in symbolic format, whereas numerical methods produce the equations of motion as complex numerical procedures. The symbolic format has the advantages of portability and efficiency, and it provides interesting insights in the analytical structure of the equations. However, numerical methods are able to deal with a more general class of problems, and they are especially suitable to model the dynamics of a flexible mechanism with complex topology in a systematic way. After this clarification, let us further characterize the modeling requirements in the design procedure, which are directly associated with the objectives of this research

### 1.2 Experimental validation and hardware implementation of designs

In an industrial process, design of controllers involve formulation of reasonably accurate models of the plant to be controlled, designing control laws based on the derived models and simulating the designed control laws using available simulation tools such as MATLAB/Simulink. Whereas implementation is accomplished by converting the designed

control laws to the native code of target systems, most commonly embedded microprocessor based architecture or personal computer with analog and digital interfaces. Controllers can be designed in the continuous, discrete or hybrid time domain whereas implementation is accomplished mostly in discrete time domain as most of the present day controllers are being implemented in digital machines. Presence of the vast difference in design and implementation of control applications is inherent due to different concepts in the field of control engineering and computer science. Thus, transformation of controller designs to implementation induces possibilities of errors and unreliable behaviors. In some cases, these errors cannot be identified by rigorous tests of the implementation thus these errors results in failure of the system causing serious and even catastrophic disaster.

Furthermore, the typical controller design task requires selection of controller strategies, structures and parameter values. Before implemented engineers should be tested using actual plant data or in prototype implementation with physically measured inputs and generated outputs. This phase is necessary for experimental validation of model simplifications and other assumptions made when designing the controller. On the other hand, real-time simulation provides the best conditions for performance tuning. However, sometimes the reverse situation occurs when plant model is substituted for the actual plant while the controller might be fully implemented. This approach is called Rapid Controller Prototyping (RCP) simulation [9-11]. For this technique, engineers have actuators, sensors and other physical components interfacing with real-time simulation. Furthermore, RCP techniques allow implementing and validating control strategies during the development process that users can work within the same environment from the requirement analysis to the controller design and implementation phase.

According to those two sets of skills, in the mechatronic design process, it can be broadly categorized into three stages in a computer-supported design environment, namely, the design problem of understanding behavior of mechatronic system through an analysis of need, initial solution generation through conceptual design, and solution refinement and finalization through multi-discipline detailed design. In computer support for engineering design, there is little support for the first two stages in the design process, primarily due to the complexity and diverse needs of these design activities during the three stages. The final stage in the design process is currently the main area that has reasonable computer support, and can be used to assist engineer designers to improve their designs or products. This stage of computer support can be further decomposed into component modeling, component matching and sizing, and behavior simulation and comparison for informative decision-making. This decomposition facilitates further investigation of the constituents of each design support activity.

Notably, one typical problem with many current computer-modeling methods is that they are extremely domain dependent. In the mechatronic system design processes, which include structural design, controller design and implementation in three domains, also consider interactions among multiple domains, such as integrated design, rapid prototyping and animation technology (Fig. 2). Therefore, mechatronic design engineers must to be trained to use in different application domains such that they would be competent in using all these domain-dependent technologies. This task itself is very challenging. Consequently, to solve dependent problems for mechatronic systems, mechatronic engineers always use a dynamic equation that includes all parameters in the structural and control domains. Unfortunately, one of the most significant problems when using equation-based mechatronic modeling is the amount of modeling data that must be analyzed during the

process. Because of this enormous amount of data and the numerical algorithm that must also be utilized, this method of modeling and simulation is typically very slow and prone to errors. Additionally, this method requires excellent knowledge of numerical solution methods and programming principles.

Based on those reasons, in order to easy integrated design and simulation of mechatronic system for different concept domains, in this study the graphical environment called Computer Aided Rapid System Integration (CARSI) technology will be developed to achieve the structure design, controller design and implementation in the same design environment.

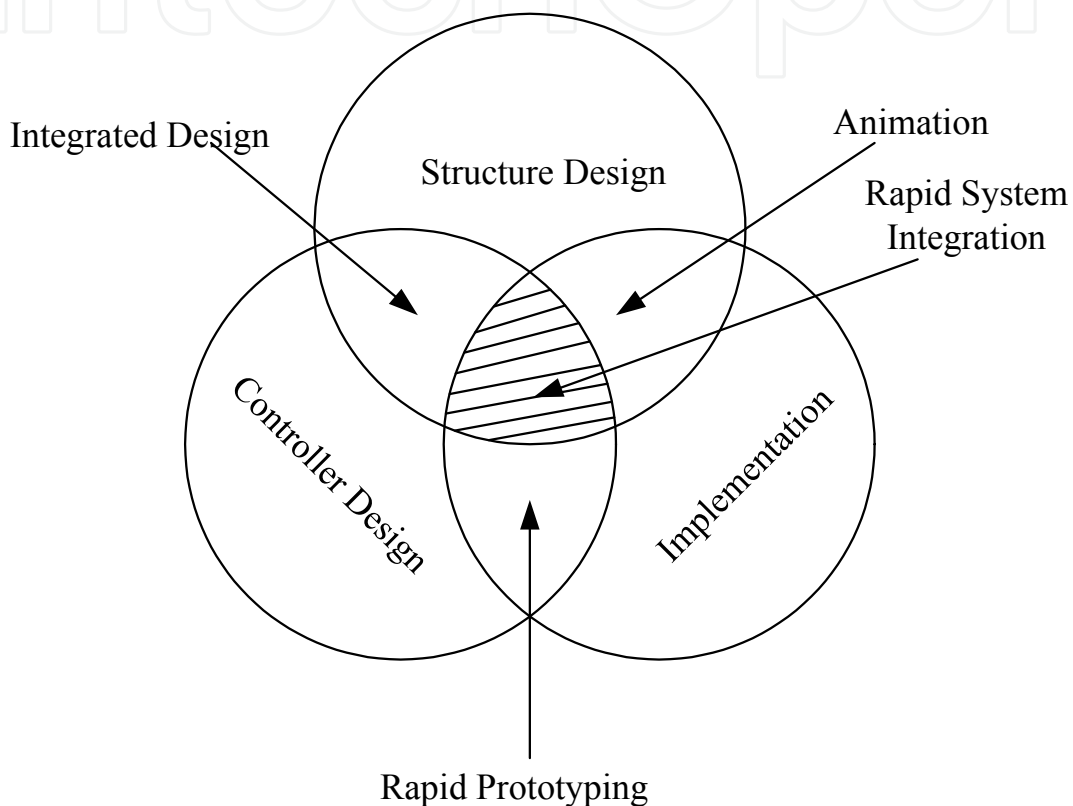

Fig. 2. Skills for mechatronic system design.

In this chapter, next section will describe the integrated design strategy using the sequential, iterative, and simultaneous methods. In Section 3, the integrated design method DFC will employ to develop a legged mechatronic system. Followed by section 4 and section 5 will present CARSI technology to put together the design, simulation and implementation at same environment. The end is concludes the work in this chapter.

## 2. Integrated design strategy

With a multilevel decomposition approach [12], a large complex optimization problem is broken into a hierarchy of smaller optimization sub problems. This hierarchy can be thought as levels of increasing details. At the upper level, the sub problem is formulated in terms of global quantities, which describe the overall behavior of the entire system. On the lower level, the sub problems are stated in terms of local quantities and local constraints, which have only a small impact on the entire system. Each sub problem uses local design variables

to reduce the violation of constraints, which are unique to that sub problem. Each level is a multi-objective optimization problem characterized by a vector of objective functions, constraints and design variables. So considering the structure and control two-level problem for a mechatronic system, the multilevel decomposition procedure can be written as below. At structure level,

$$\begin{aligned}
 & \min. \quad Y_{Ni}(X_N), i = 1, \dots, n_N \\
 & \text{s.t.} \quad g_{Nk}(X_N) \leq 0, k = 1, \dots, nc_N \\
 & \quad \sum_{i=1}^{NDV_N} \frac{\partial Y_{Rj}}{\partial X_{Ni}} \Delta X_{Ni} \leq \varepsilon_{2j}, j = 1, \dots, n_R \\
 & \quad X_{Ni}^L \leq X_{Ni} \leq X_{Ni}^U, i = 1, \dots, NDV_N \\
 & \quad X_{Rj}^L \leq X_{Rj}^* + \sum_{i=1}^{NDV_N} \frac{\partial X_{Rj}^*}{\partial X_{Ni}} \Delta X_{Ni} \leq X_{Rj}^U, j = 1, \dots, NDV_R
 \end{aligned} \tag{1}$$

where  $Y_N$  and  $Y_R$  are the objective function vectors at the structure level and the control level, respectively;  $g_N$  and  $g_R$  are the corresponding constraint vectors;  $X_N$  and  $X_R$  are the corresponding design variable vectors,  $\varepsilon_{2j}$  is a tolerance on the change in the  $j^{\text{th}}$  objective of control level during optimization at the structure level;  $L$  and  $U$  are lower and upper bounds of design vectors,  $\partial Y_{Rj}^*/\partial X_{Ni}$  and  $\partial X_{Rj}^*/\partial X_{Ni}$  represent the optimal sensitivity parameters of the control level objective function and design variable vectors, respectively, with respect to the structure level design variables.  $n_N$  and  $n_R$  denote numbers of objective functions for each level;  $nc_N$  is the number of constraints for structure level;  $NDV_N$  and  $NDV_R$  are numbers of design variables for the structure and the control levels.

Similarly, the process of control level becomes

$$\begin{aligned}
 & \min \quad Y_{Rj}(X_N^*, X_R), j = 1, \dots, n_R \\
 & \text{s.t.} \quad g_{Rk}(X_N^*, X_R) \leq 0, k = 1, \dots, nc_R \\
 & \quad X_{Ri}^L \leq X_{Ri} \leq X_{Ri}^U, i = 1, \dots, NDV_R
 \end{aligned} \tag{2}$$

Where  $X_N^*$  is the optimum design variable vector from the structure level and must be fixed during optimization at the control level.

Following (1) and (2); the integrated design methodology can be broken into sequential, iterative, and simultaneous three strategies:

In the sequential strategy, the mechanical structure is usually designed first (Eq. 1). It is then fitted with off-the-shelf electric motors and drive electronics. Finally, a controller is designed and tuned for the existing physical system until the goal is archived (Eq. 2); therefore, it is called Design Then Control (DTC) strategy. In this method, the structure is assumed to be fixed and cannot be changed by excluding considerations from a dynamics and control point of view. Consequently, this approach leads to a system with non-optimal dynamic performance.

Based on this reason, in order to improvement system performance, the iterative strategy is discussed. For this method, the structural design is also first performed based on loading

considerations (Eq.1). Sizes and masses of mission-related components are estimated and a structure that maintains the desired component relationships during operations is designed. Next, a controller is designed for the fixed structure to obtain the required dynamic performance (Eq.2). The control design must also provide satisfactory closed-loop stability and robustness properties. If the nominal system does not provide an adequate performance, the design process must return to the structural discipline for modification (Eq. 1). After modification, the structure parameters are returned to the control discipline for redesign (Eq.2). This iterative process continues until a satisfactory compromise is found between the mission and control requirements. Now suppose that it is desired to simplify the (1) and (2) formulation as much as possible. One could presumably simplify the problem by assuming that all the objective functions and constraints are convex within both the structure and controller design subspaces. In other words, one could presumably assume that, when the structure design variables  $X_N$  are fixed, all the objective functions and constraints in the above problem will be convex and vice versa. However this assumption is not a sufficient guarantee for the system level optimization problem to be convex [7]. Thus, in order to achieve the optimization problem into the system level, the simultaneous design strategy must be considered.

As (1) and (2), given a combined structure and controller optimization problem for mechatronic system, the system level is often nonconvex, even if the individual structure and control optimization sub-problems are convex (individual design problem for (1) and (2)). The main reason is easy involved the static and variation optimization problem during iterative design process. Thus, some of researchers were used closed-loop eigenvalues [2][3], Design For Control (DFC) [5][6][23], and convex integrated design [8] to improve structure and control problem simultaneous.

Therefore, as Fig.3 shows, comparing above three strategies, even system performance will be increased during sequential, iterative, and simultaneous strategies, but

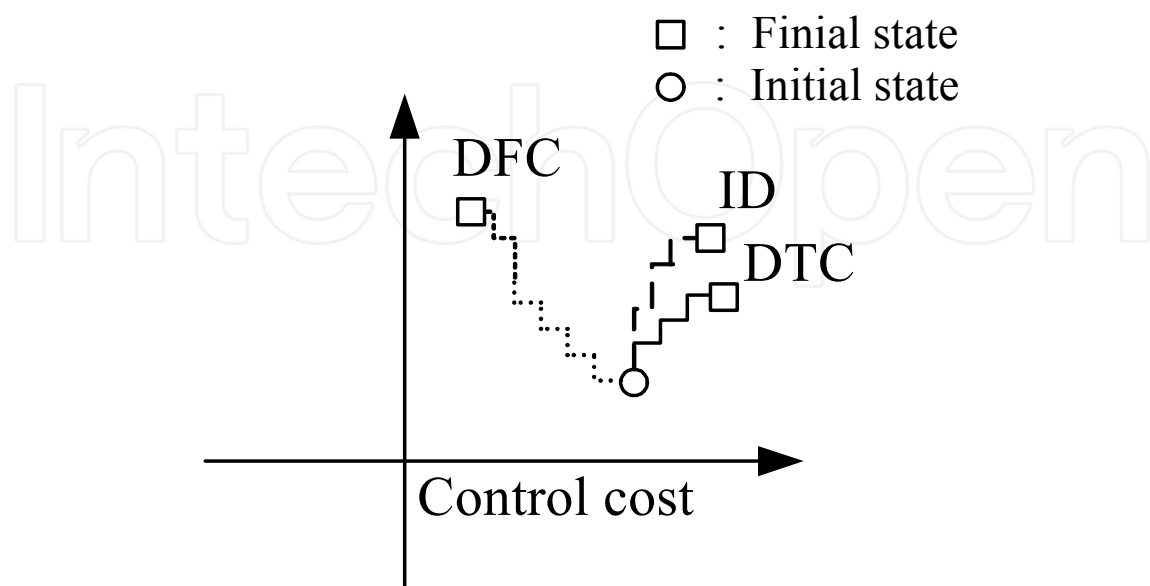

Fig. 3. Control cost in iterative process.

### 3. Legged mechatronic system design

Most mobile robots are equipped with wheels. A wheel is easy to control and direct, provides a stable base on which a robot can maneuver and is easy to construct. However, one major drawback of a wheel is the limitation it imposes on the terrain the can be successfully navigated. Therefore, research into legged locomotion is important as legs can overpass rough terrain. Thus, create a leg mechanism that walks has become a central goal in the field of robotics [13-15]. Based on this reason, in this study, the CARSI will be used in rapid legged mechatronic system design process, and the flow chart shows in Fig. 4.

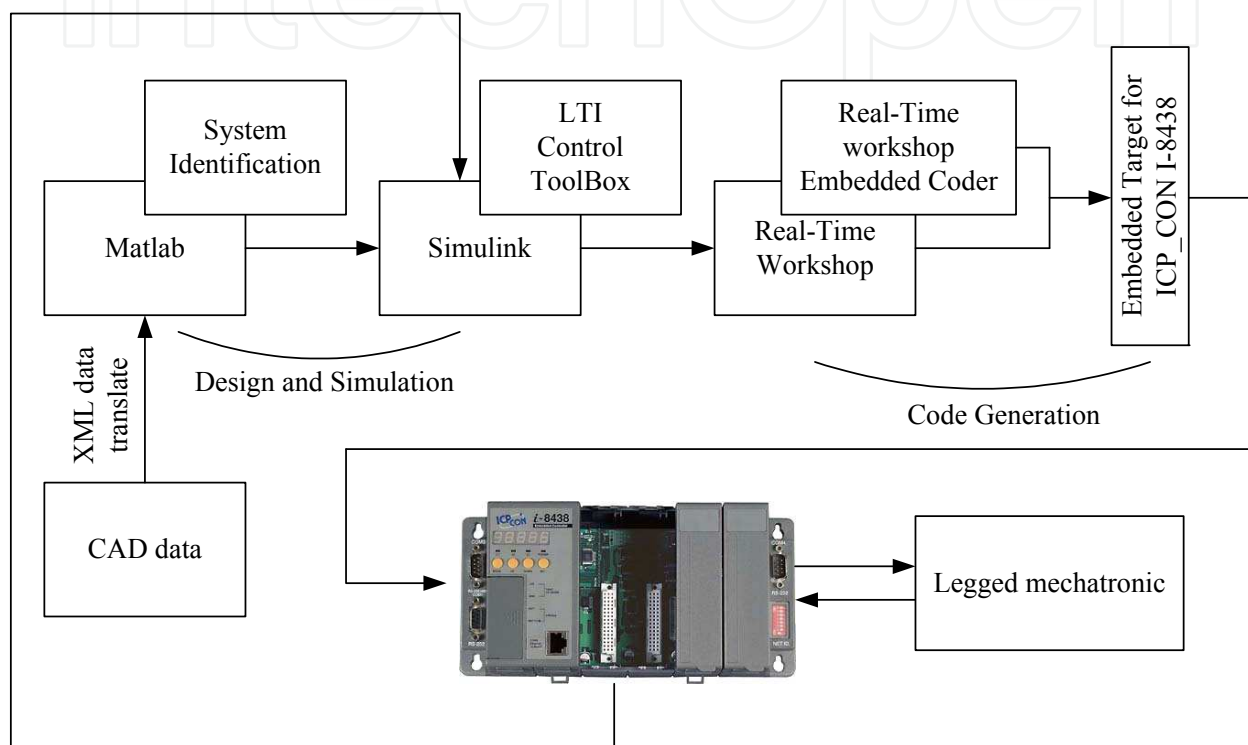

Fig. 4. Legged mechatronic system design flow chart.

#### 3.1 Legged structure

Basic considerations for a leg design for a walking machine are as follows: the leg should generate an approximately straight-line trajectory for the foot with respect to the body; the leg should have a simple mechanical design; and, when specifically required, it should have the minimum number of DOFs to ensure motion capability. Therefore, the basic principle in this study is to create a walking machine via the linkage method with symmetrical coupler curves to combine the functions of a four-bar linkage and a pantograph into one leg structure [16][17].

Based on the embedded-type leg mechanism (Fig. 5), an embedded trajectory P is first designed via a four-bar linkage, and then magnified by a scale ratio  $n$  ( $B_0E=nB_0D$ ) to obtain the gait profile G. Therefore, according to design specifications (Table 1), the parameters of the embedded four-bar linkage are obtained. Moreover, all design processes are based on the following assumptions:

1. No transmission loss exists between the input and end effect of this mechanism.
2. Ground reaction force on the end effect is constant.



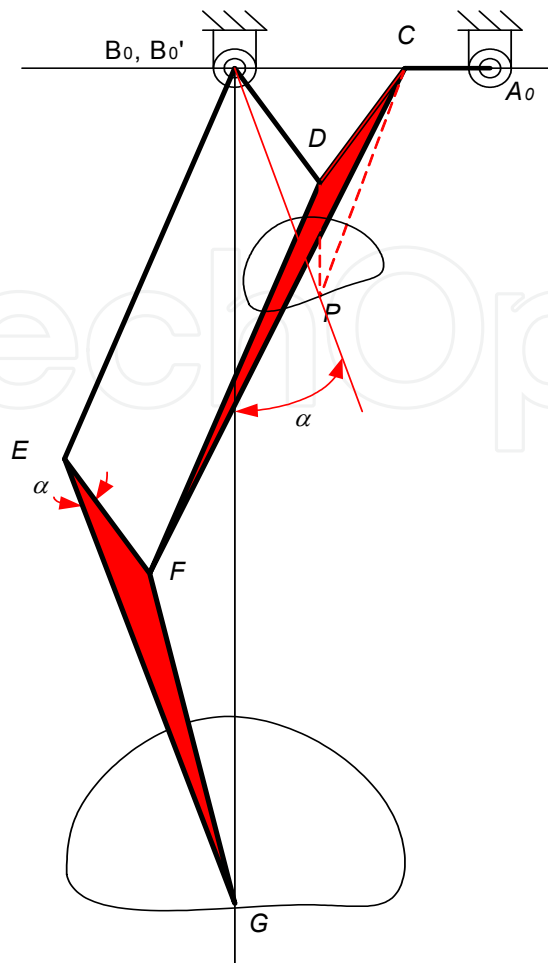

Fig. 5. Legged structure.

### 3.2 Optimal multivariable design for gait profile

As discussed, gait profile can be designed using an embedded four-bar linkage, and magnified using a pantograph to satisfy the target. Additionally, to decrease leg size (or minimize scale ratio  $n$ ) and obtain an enhanced footpath height, the design objective function can be formulated as (3).

$$I_1 = \min (\beta(l_s)^{-1} + \gamma(l_h)^{-1}) \quad (3)$$

s.t.

$$\phi \geq 2 \cos^{-1} \sqrt{\cos \beta_1 \sin \beta_2}$$

$$12cm \leq \overline{A_0B_0} \leq 14cm$$

$$2cm \leq \overline{A_0C} \leq (2\overline{CD} - \overline{A_0B_0})cm$$

$$\pi < \mu + \phi' < 2\pi$$

$$45^\circ \leq \mu \leq 135^\circ$$

where:

$\beta, \gamma$  : weighting factor,  $\beta = 1, \gamma = 0.2$

$l_s$  : stride length of the embedded four-bar linkage  
 $l_h$  : foot-path height of the embedded four-bar linkage  
 $\alpha$  : skew angle

$$\angle CDF = \phi + \alpha = \phi'$$

Table 2 lists optimal results based on (3) and those constrains. Additionally, Fig. 6 shows the six-bar walking machine gait profile and the embedded four-bar linkage profile.

Parameters	DTC	DFC	Var. %
Structure Parameters			
$\overline{A_0B_0}$ (cm)	12.8	12.8	-
$\overline{A_0C}$ (cm)	2.6	2.6	-
$\overline{B_0D} = \overline{EF}$ (cm)	8	8	-
$\overline{B_0E} = \overline{DF}$ (cm)	30.8	30.8	-
Mass of $\overline{A_0C}$ (kg)	0.050	0.080	60
Mass of $\overline{B_0D}$ (kg)	0.035	0.07	100
Mass of $\overline{B_0E}$ (kg)	0.134	0.134	-
Mass of $\Delta CDF$ (kg)	0.368	0.215	-41.5
Mass of $\Delta EFG$ (kg)	0.316	0.177	-44.0
r2(cm) / $\delta_2$ (deg)	1.3 / 0	0 / 0	- / -
r3(cm) / $\delta_3$ (deg)	16.0 / 35.6	14.6 / 38.0	-8.6 / 6.3
r4(cm) / $\delta_4$ (deg)	4 / 0	0 / 0	- / -
r5(cm) / $\delta_5$ (deg)	12.5 / 42.0	11.6 / 36.6	-7.5 / -13
r6(cm) / $\delta_6$ (deg)	15.4 / 0	15.4 / 0	- / -
$\alpha$ (deg)	51.2	51.2	-
n	3.8	3.8	-
$\phi'$ (deg)	128.8	128.8	-
Controller Parameters			
$K_p$	4.3	3.5	-18.6
$K_i$	4000	4800	20
$K_{pp}$	150	180	20
Max $ \tau $ (N-m) without acc/dec (0.5 step/s)	0.14	0.12	-10
Max $ \tau $ (N-m) without acc/dec (2 step/s)	0.5	0.2	-60

Table 2. Integrated Design Results.

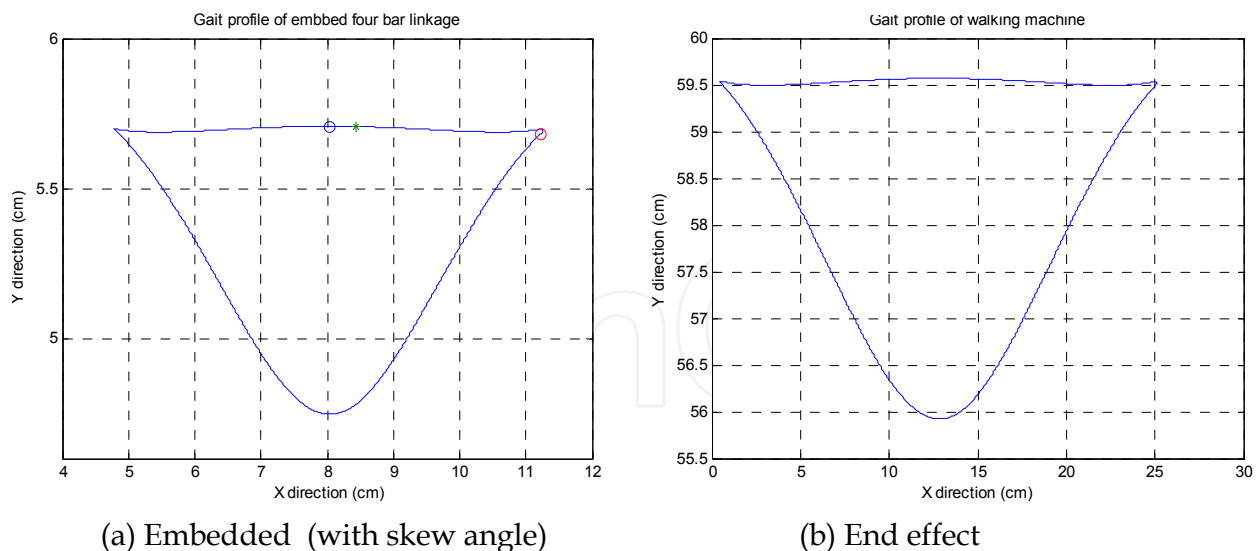

Fig. 6. Gait profile.

### 3.3 Controller design

When kinematic design of the walking machine was complete, controller design was considered. Therefore, to integrate and model the mechatronic system of a walking machine in the design process, Lagrange's equation, which formulated as (4), is applied to derive the all parameters in this controller design process.

$$\frac{d}{dt} \frac{\partial K}{\partial \dot{\theta}_2} - \frac{\partial K}{\partial \theta_2} + \frac{\partial P}{\partial \theta_2} = \tau \quad (4)$$

where  $K$  is kinetic energy,  $P$  is potential energy,  $\tau$  is control torque, and  $\theta_2$  is angle of the input link. Fig. 7 presents the detailed parameters of a system dynamic for a walking machine. Thus, the primary parameters  $K$  and  $P$  can be expressed by (5) and (6), and control torque  $\tau$  was re-formulated as (7).

$$K = \sum_{i=2}^6 \left[ \frac{1}{2} m_i (V_{ix}^2 + V_{iy}^2) + \frac{1}{2} J_i \dot{\theta}_i^2 \right] \quad (5)$$

$$P = (m_2 r_2 \sin(\theta_2 + \delta_2) + m_3 (L_2 \sin \theta_2 + r_3 \sin(\theta_3 + \delta_3)) + m_4 r_4 \sin(\theta_4 + \delta_4) + m_5 (L_2 \sin \theta_2 + L_3' \sin(\theta_3 + \rho_3) + r_5 \sin(\theta_5 + \delta_5) + m_6 r_6 \sin(\theta_6 + \delta_6))) g \quad (6)$$

where  $m_i$  is mass of each linkage;  $V_{ix}$  and  $V_{iy}$  are the velocity in the  $x$  and  $y$  direction, respectively, for each linkage;  $r_i$  is the length from the central mass to a reference point;  $L_i$  is the characteristic length for each linkage;  $\delta_i$  is the angle of central mass for each linkage;  $g$  is gravity;  $L_3' = (L_3^2 + L_6^2 - 2L_3L_6 \cos \phi')^{0.5}$ .

In the other hand, use of simple controllers, such as PD/PID controllers, for industrial manipulators and servo system applications are well known which works on the basis of position loop control. In this work, in order to improve tracking performance for velocity and position simultaneously, the IP controller was employed in the velocity loop, and the P

controller was used in the position loop. The equation of control power  $\tau$  can be formulated in (7).

$$\tau(t) = K_i \int (e_\theta K_{pp} - \omega_m) dt - K_p \omega_m \tag{7}$$

where  $e_\theta$ ,  $K_{pp}$ ,  $K_p$  and  $K_i$  are position tracking error, position loop proportion gain, velocity loop proportion gain, and velocity loop integration gain, respectively. Following the Integral Time Absolute Error (ITAE) criteria, the design objective for the controller was written as (8), where  $\eta$  and  $\zeta$  are weight factors, and  $\eta = 1$ ,  $\zeta = 0.1$ , the results are listed in Table 2.

$$\begin{aligned} I &= \min(\eta \int t |e_\theta(t)| dt + \zeta |\tau(t)|) \\ \text{s.t } \tau(t) &\leq 5 \text{ Nm} \\ e_\theta &\geq 0 \end{aligned} \tag{8}$$

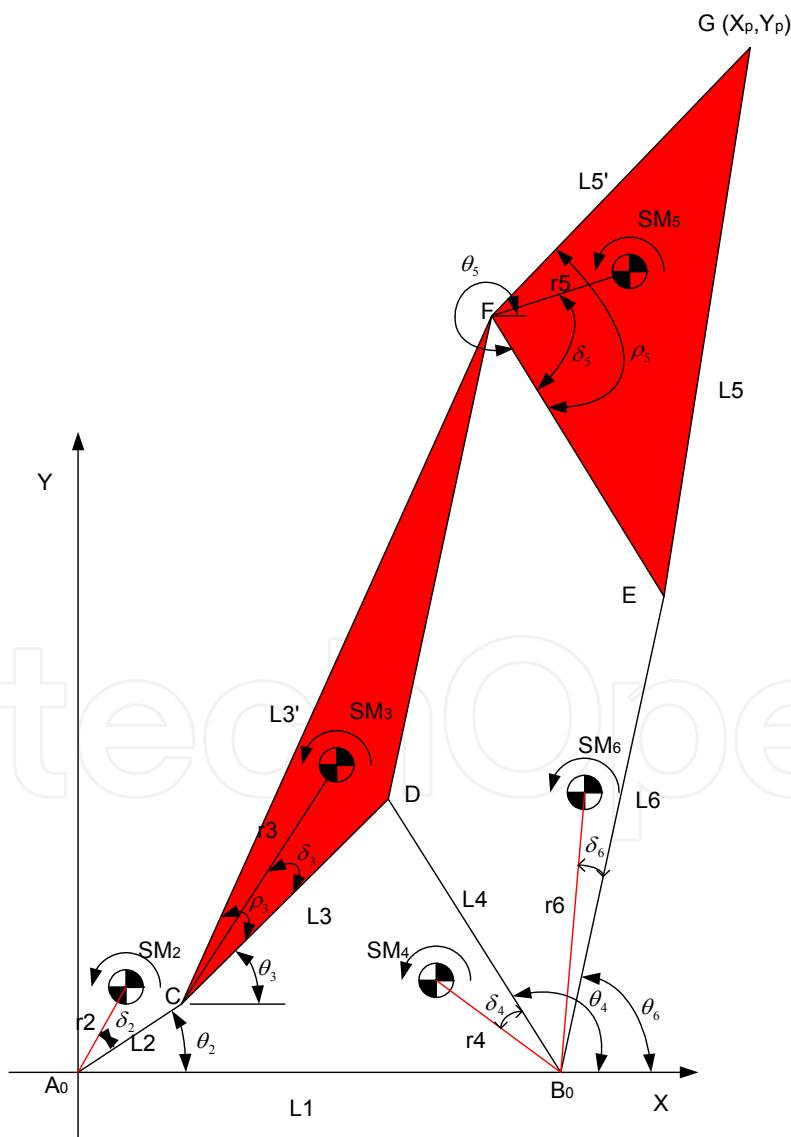

Fig. 7. Dynamic model of linkage for Leg system.

#### 4. System optimization using the Design For Control (DFC) approach

As Fig. 8 shows the DFC iterative process [5][6][23], if system performance is unsatisfactory, design process is returned to structural domain. The structural modification process will go out of used the single domain constrains, and overall system dynamic conditions will be replaced with original conditions, and pass into control domain to acquire a new controller solution. Hence, DFC is not only used a concurrent (parallel) integrated design process to achieve system performance, but also to enhance the control requirements to easy control system in the design approach.

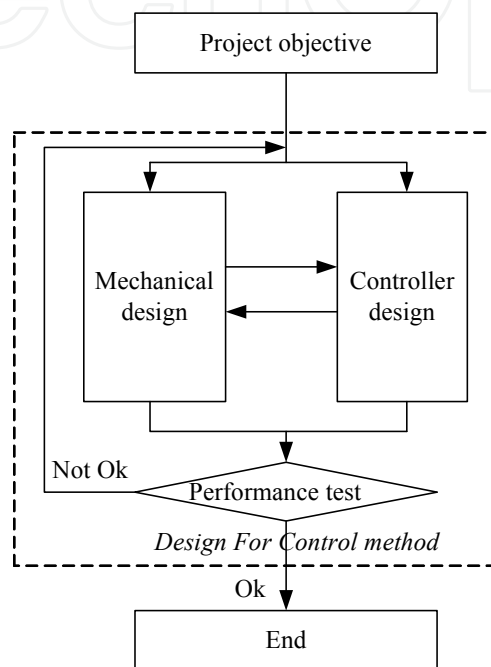

Fig. 8. Integrated design of mechatronic system using DFC.

Following use of the DFC concept and Lagrange's equation, the aim of the design process is to decrease potential and kinetic energy first during these interactive design processes. Thus, modifying system parameters of the leg linkage for the walking machine must be considered, and system performance is based on structural results (5) and (6) in tuning the controller parameters (7) at the same time. Therefore, following (5) and (6), two methods can be utilized to improve system performance, namely, variable input speed [18], which reduces kinetic energy for (5), and mass redistribution [5-6], which decreases both terms (5) and (6) simultaneously. Thus, the "complete force balancing" method based on mass redistribution was applied to enhance system performance. Hence, the primary objective in this interactive process can be formulated as (9).

Based on this objective, when (9) equals zero, the dynamic equation for legged mechatronic can be re-formulated as (10). From this equation, the dynamic behavior for this mechatronic leg can be also reduced to a simple equation, i.e., control power is only considered as kinetic energy and near constant potential energy during this interactive control design process. As mentioned earlier, the basic idea of the DFC approach is to spare control design effort and improve real-time performance by providing a simple dynamic model through judicious mechanical design. Consequently, key parameters of the internal moment,  $\delta_i$ ,  $r_i$ , and  $m_i$ , were improved (Table 2). Additionally, Table 2 also lists optimal control gains.

$$I = \min \frac{\partial P}{\partial \theta_2} \quad (9)$$

$$\frac{d}{dt} \frac{\partial K}{\partial \dot{\theta}_2} - \frac{\partial K}{\partial \theta_2} = \tau \quad (10)$$

#### 4.1 Multi-domain graphical model integration

With the rapid developments in computer science over the last 20 years, computer-aided engineering software, such as Pro/Engineer, Solidworks, Ansys and Matlab, have been widely utilized in structure and control fields. Therefore, file format standards, such as the Initial Graphics Exchange Specification (IGES), STEP (ISO-10303) and DXF, were developed to address the incompatibility issue of various CAD/CAM systems. This standard allows for efficient and accurate exchange of product definition data across almost all CAD/CAM systems.

As each computer-aided engineering software package using a unique method of describing geometry both mathematically and structurally, some information is always lost when translating data from one system data format to another. Intermediate file formats are also limited in what they can describe, and can be interpreted differently by both the sending and receiving systems. When transferring data between systems, identifying what needs to be translated is important. Additionally, translating intermediate files always focuses on the same engineering domain. Therefore, in the mechatronic system, intermediate file formats or parameters must be considered in detail to be accepted by each domain. That is, modeling of different system domains in the same model is possible when the language used for describing the model is extensible and includes several standard libraries for different domains; this helps users because they can use modeling tools with which they are familiar for different tasks.

XML (eXtensible Markup Language) is a World Wide Web Consortium (W3C) recommended general-purpose markup language that supports a wide variety of applications [19]. The XML language and its 'dialects' can be designed by anyone and can be processed using appropriate software. Notably, XML is also designed to be reasonably human-legible.

According to kinematic synthesis results for the leg linkage (Table 2), the 3D graphical model for the mechatronic leg was first designed using Pro/E (Fig. 9(a)). Moreover, based on the (4), (5), (6), parameters of linkages, such as mass, length, position, center of gravity, unit, volume, and constrain (or joint type), were obtained from this CAD data. Following this step, the graphical model, based on XML syntax, in reference to control requirement parameters was obtained. According to this model and parameters (Table 2), the embedded controller was also created using this graphical model (Fig. 9(b)). Consequently, to simplify modeling and simulation for the mechatronic system in this study, a graphical environment called CARSI technology was employed for structural design, controller design and implementation in the same design environment.

Based on CARSI method, Fig. 10(a) and 10(b) present results obtained by the DTC and DFC methods, respectively. Comparing the simulation results obtained with DTC and DFC, the performance of the mechanism after applying the mass-redistribution scheme was significantly improved; the maximum control torque at low and high speeds was reduced by 10%, from  $\pm 0.14$ N-m to  $\pm 0.12$  N-m and 10%, from  $\pm 0.5$ N-m to  $\pm 0.2$  N-m, respectively.

According to these analytical results, once the mass and mass center are fixed during machine walking, the potential energy term will have almost no influence even when speed is changed. Conversely, based on the DTC result, when walking speed changed, control power increases.

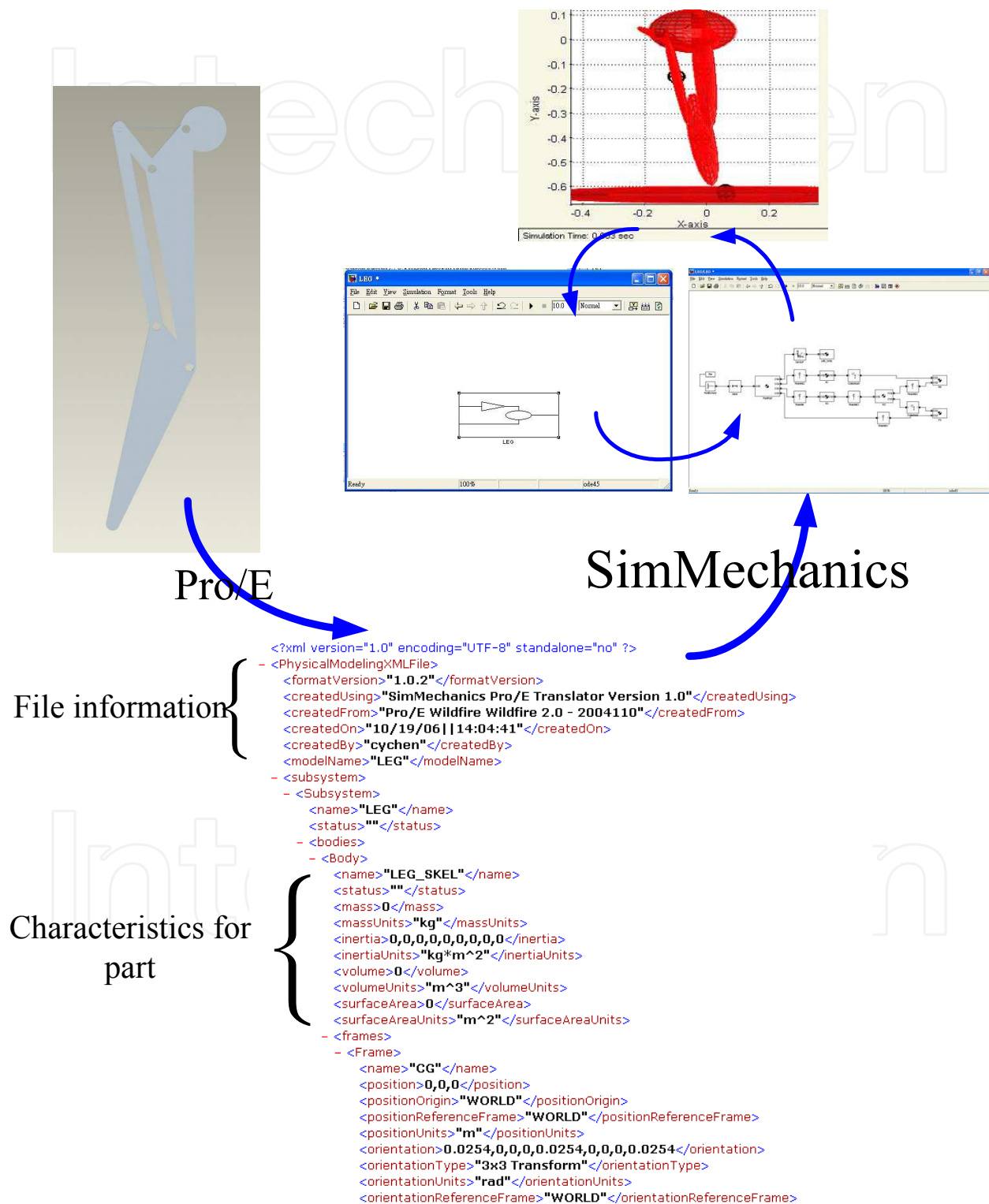

Fig. 9. (a) Multi-domain transforms

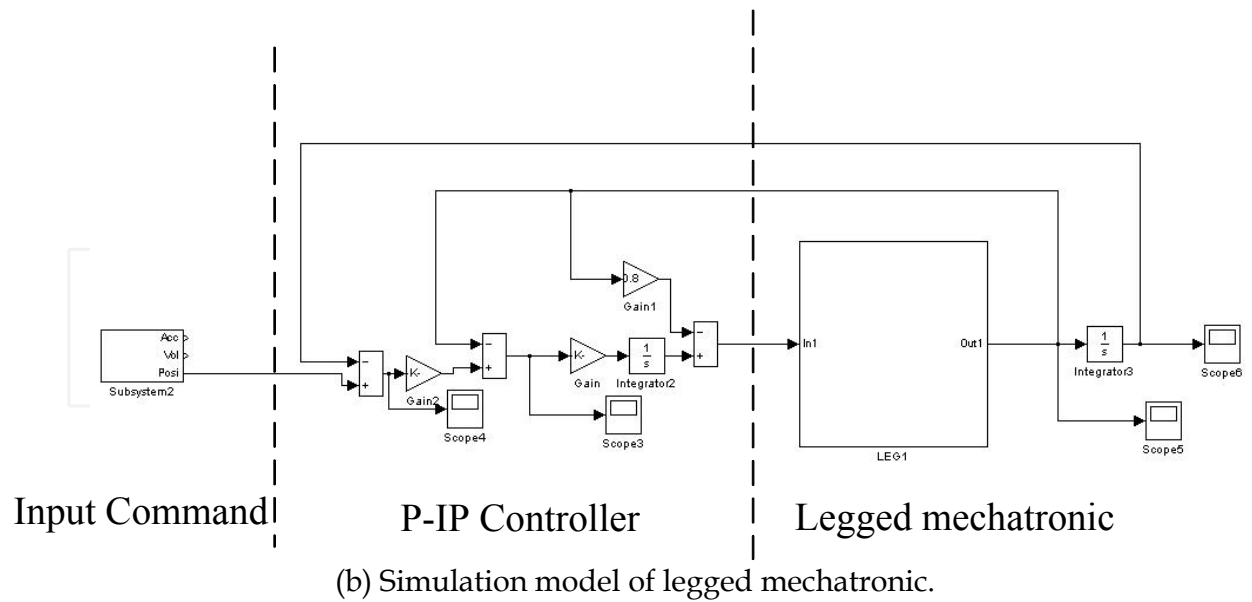

Fig. 9. Multi-domain graphical model.

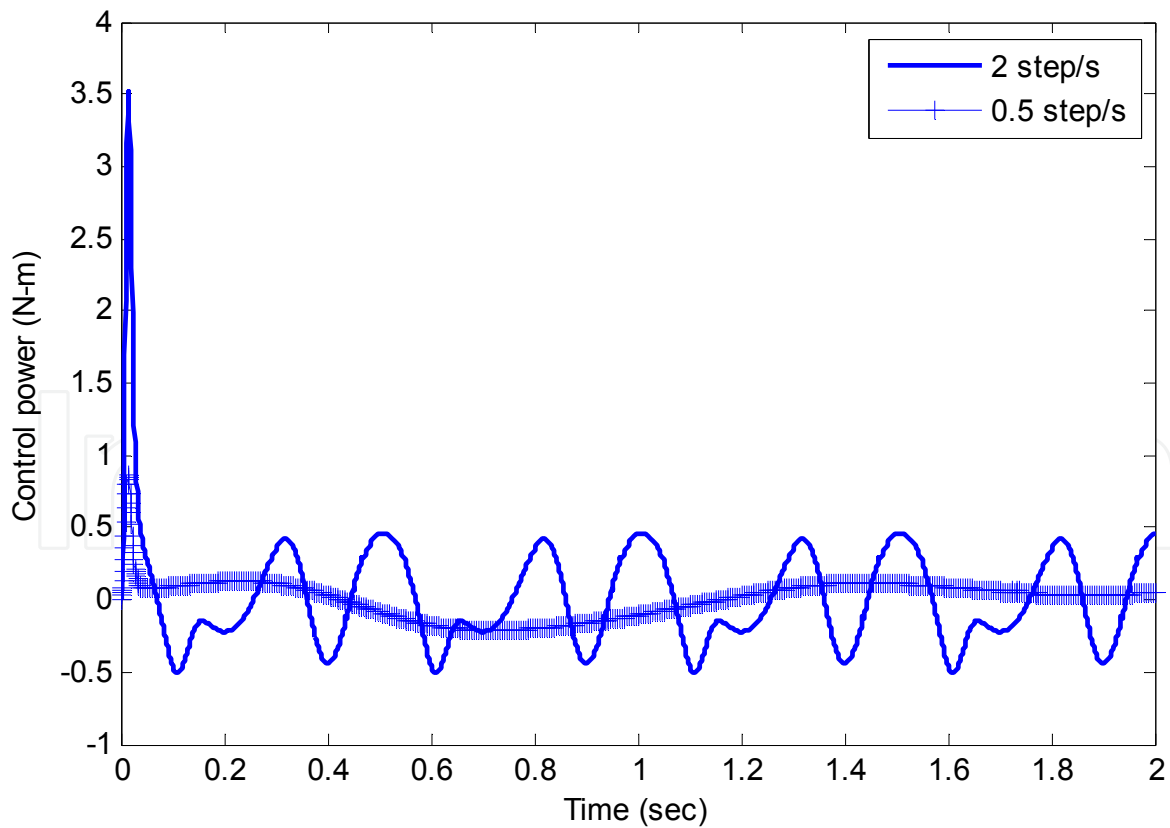

Fig. 10. (a)



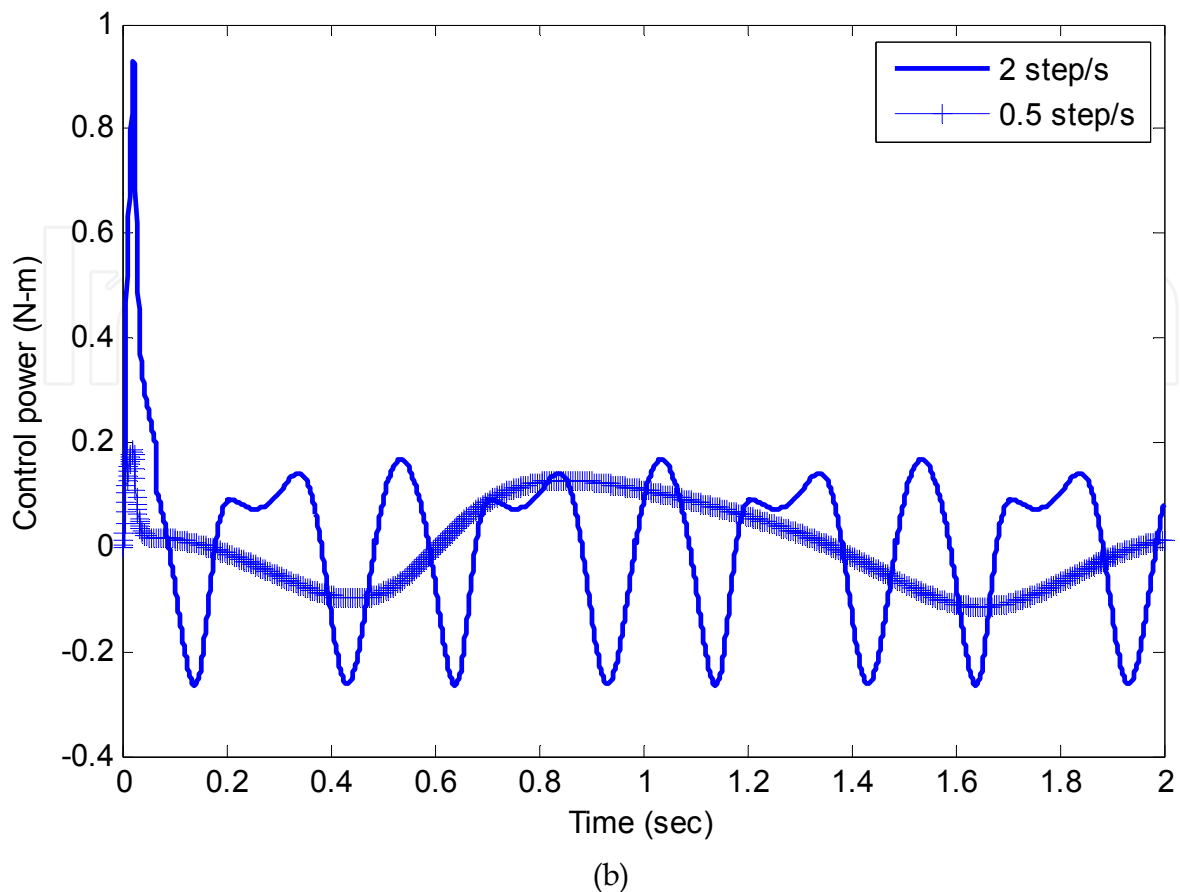

Fig. 10. Control power for DTC and DFC methods.

## 5. Rapid control prototyping

As control systems become increasingly complex with the development of control algorithms and controller designing techniques, manually interpreting and designing the control system using differential equations or numerical formulas is time-consuming and difficult. Additionally, various user-friendly graphs and interfaces are necessary as well as complex computations, and, moreover, because repetitive operations on the same work is mandatory when designing a control system, conventional handwork programming is not an easy job and is inefficient when faced with increased pressure for reducing product time-to-market.

Rather than conventional low-level programming languages, graphical model-based programming has been used increasingly for real-time simulation and hardware-in-the-loop (HIL) applications to obtain rapid prototyping of various electrical and mechanical systems. Compared with conventional low-level handwork programming, the most important feature of state-of-the-art control applications is the function that generates program codes automatically through some user-friendly graphic modules to decrease the time required for system development.

As mentioned, "Matlab/Simulink" software is a design and simulation tool used most in the control field. This software allows users to create models for dynamic systems simply by connecting blocks from given libraries, and also includes a library called SimMechanics, which simulates rigid body dynamics using a 3D graphical model. Some blocks of

Matlab/Simulink implement linear systems given as transfer functions or state-space realizations both in continuous and discrete time. When a simulate is complete, the Real-Time Workshop (RTW) toolbox generates C-code from the model without a need for programming knowledge. Therefore, rapid controller prototyping techniques facilitate implementation and validation of control strategies during the development process: users can work within the same environment from structure requirement analysis to the controller design and implementation phases. Based on this software, three implementation types are supported by the RTW toolbox, namely, Real-Time Windows Target, xPC target, and Real-Time Embedded Target. For the first two techniques, the target real-time devices are based on PC. Therefore, real-time performance or space must be considered in detail [20].

As previously stated, Figure 11 presents the “ICPDAS i8438” module, which is based on a micro-chip and provides some add-on modules such as analogy output (I-8024) and encoder feedback (I-8090) [21]. According to this model and legged mechatronic system (Fig. 12(a)), the simulation and experimental results are shows in Fig. 12(b).

As these results, the constant friction torque from each joints was assumed at 0.3 N-m. The experimental and simulation results are very close; however, one obvious problem with this result is that dynamic friction during the acceleration phase was not considered. Restated, integration of a graphical-based model and equation-based model to simulate a mechatronic system can easily obtain, predict and modify system model parameters to achieve the goal for a real system.

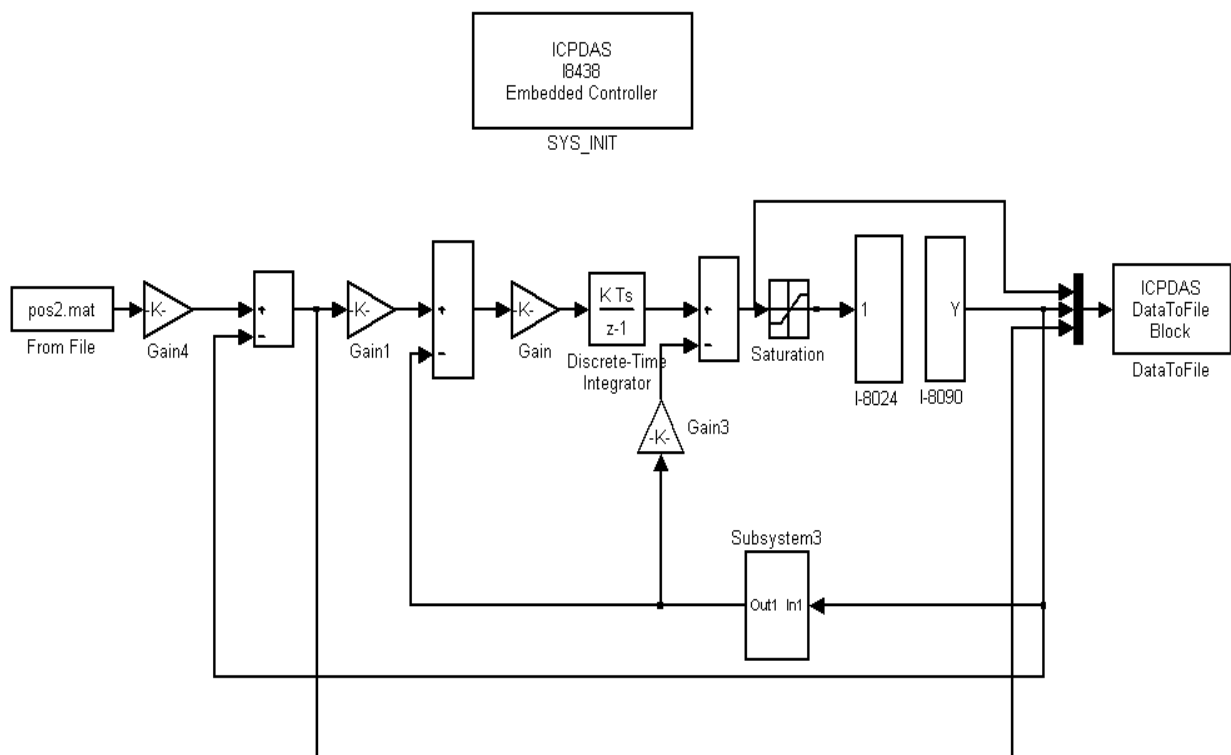
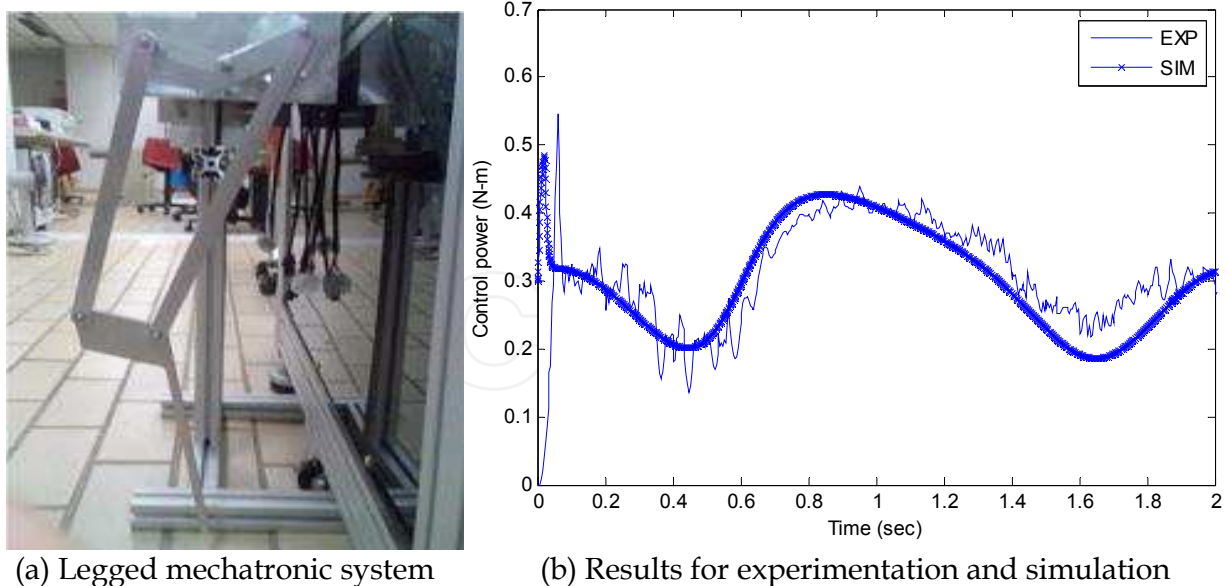

Fig. 11. Model for HIL.



(a) Legged mechatronic system

(b) Results for experimentation and simulation

Fig. 12. Legged mechatronic.

## 6. Conclusion

An integrated design concept DFC and rapid implementation CARSI for a walking machine are proposed in this paper. The DFC was utilized to design the mechanical structure of a mechatronic leg system by fully exploring the physical characteristics of the overall system while considering controller design and execution of control actions with the least significant hardware restriction. Restated, DFC not only helped the mechatronic system satisfy low driving power, its also helped easy to control the system. Additionally, the CARSI approach achieved structural design, controller design and system implementation simultaneously in the same design environment to reduce development time for the mechatronic leg system.

## 7. References

- [1] A.L. Hale, R.J. Lisowski, and W.E. Dahl, "Optimal simultaneous structural and control design of maneuvering flexible spacecraft," *J. of Guidance Controller and Dynamics*, Vol. 8, No. 1, pp. 86-93, 1985.
- [2] D.S. Bodden and J.L. Junkins, "Eigenvalue optimization algorithms for structure/controller design Iterations," *J. of Guidance Controller and Dynamics*, Vol. 8, No. 6, pp. 697-706, 1985.
- [3] Messac, "Control-structure integrated design with closed-form design metrics using Physical Programming," *AIAA Journal*, Vol. 36, No. 5, pp. 855-864, 1998.
- [4] J.H. Park and H. Asada, "Concurrent design optimization of mechanical structure and control for high speed robots," *ASME Journal of Dynamic System, Measurement, and Control*, Vol. 116, pp. 344-356, Sep. 1994.
- [5] F. X. Wu, W. J. Zhang, Q. Li, and P. R. Ouyang. "Integrated design and PD control of High Speed Closed-loop Mechanisms," *ASME Journal of Dynamics System, Measurement and Control*, Vol. 124, No.4, pp. 522-527, 2002

- [6] Q. Li, and F. X. Wu, "Control Performance Improvement of a Parallel Robot via the Design for Control Approach," *Mechatronics*, vol.14, no.8, pp.947-964, 2004
- [7] A.C. Pil and H. Asada, "Integrated structure/control design of mechatronic system using a recursive experimental optimization method," *IEEE/ASME Transactions on Mechatronics*, Vol. 1, No. 3, pp. 191-203, 1996.
- [8] K. Fu and J. K. Mills, "A Convex Approach Solving Simultaneous Mechanical Structure and Control System Design Problems With Multiple Closed-loop Performance Specifications," *ASME Journal of Dynamic Systems, Measurement, and Control*, Vol. 127, pp.57-68, 2005.
- [9] Manfred Glesner, Andreas Kirschbaum, Frank-Michael Renner, and Burkart Voss, "State-of-the-art in rapid prototyping for mechatronic systems," *Mechatronics*, Vol. 12, No. 8, pp. 987-998, 2002
- [10] Roberto Bucher and Silvano Balemi, "Rapid controller prototyping with Matlab/Simulink and Linux," *Control Eng Prac*, Vol. 14, No. 2, pp. 185-192, 2006.
- [11] M. Deppe, M. Zanella, M. Robrecht and W. Hardt, "Rapid prototyping of real-time control laws for complex mechatronic systems: a case study," *Journal of Systems and Software*, Vol. 70, No.3, pp. 263-274, 2004.
- [12] Chattopadhyay and N. Pagaldipti, "A multidisciplinary optimization using semi-analytical sensitivity analysis procedure and multilevel decomposition," *Computers Math. Applic.*, Vol. 29, No. 7, pp. 55-66, 1995.
- [13] Manuel, Pablo Gonzalez de Santos. *Climbing and Walking Robots*. Springer Berlin Heidelberg, Germany, 2005.
- [14] M. O. Tokhi , M. A. Hossain and G. S.Virk "Climbing and Walking Robots," Springer Berlin Heidelberg, Germany, 2006.
- [15] Y. J. Chen, "Mechanism Design of An 8-link Type Biped Walking Machine with Auxiliary Wheels," Master thesis, National Cheng Kung Univ., 2004
- [16] W. B. Shieh, L. W. Tsai and S. Azarm, "Design and Optimization of a One-Degree-of-Freedom Six-Bar Leg Mechanism for a Walking Machine," *Journal of Robotic System*, Vol. 14, No.12, pp. 871-880, 1997.
- [17] E. Ottaviano, C. Lanni and M. Ceccarelli, "Numerical and Experimental Analysis of a Pantograph-Leg with a Fully-Rotative Actuating Mechanism," *Proc. of the 11<sup>th</sup> World Congress in Mechanism and Machine Science*, Tianjin, China, 2004
- [18] H. S. Yan and R. C. Soong, "Kinematic and dynamic design of four-bar linkages by links counterweighing with variable input speed," *Mech Mach Theory*, Vol. 36, No.9, pp. 1051-1071, 2001.
- [19] J. Yang, S. Han, J. Cho, B. Kim, H. Y. Lee, "An XML-based macro data representation for a parametric CAD model exchange," *Computer-Aided Design and Applications*, Vol. 1, No. 1-4, pp. 153-162, 2004.
- [20] C. Sun, "The Integration of MATLAB and Embedded Controller for Control Application," Master thesis, National Sun Yat-Sen Univ., 2004

- [21] ICP DAS Co. User manual of I8438/8838 Matlab embedded control.
- [22] K. Craig, F. Stolfi, "Teaching control system design through mechatronics: academic and industrial perspectives." *Mechatronics*, Vol 12, No. 2, pp. 371-381, 2002.
- [23] Q. Li, W.J. Zhang and L. Chen, "Design for control-a concurrent engineering approach for mechatronic systems design," *Mechatronics, IEEE/ASME Transactions on Mechatronics*, Vol. 6 , No. 2, pp. 161-169, 2001.
- [24] J, van Amerongen, "Mechatronic design", *Mechatronics*, Vol. 13, No. 10, pp. 1045-1066, 2003.
- [25] K. Craig, "The role of computers in mechatronics", *Computing in Science & Engineering*, Vol. 5, No. 2, pp. 80-85, 2003.

IntechOpen

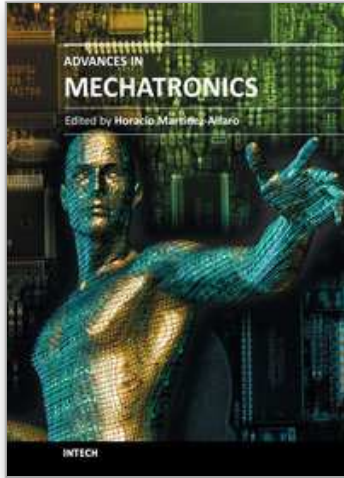

### **Advances in Mechatronics**

Edited by Prof. Horacio Martinez-Alfaro

ISBN 978-953-307-373-6

Hard cover, 300 pages

**Publisher** InTech

**Published online** 29, August, 2011

**Published in print edition** August, 2011

Numerous books have already been published specializing in one of the well known areas that comprise Mechatronics: mechanical engineering, electronic control and systems. The goal of this book is to collect state-of-the-art contributions that discuss recent developments which show a more coherent synergistic integration between the mentioned areas. The book is divided in three sections. The first section, divided into five chapters, deals with Automatic Control and Artificial Intelligence. The second section discusses Robotics and Vision with six chapters, and the third section considers Other Applications and Theory with two chapters.

#### **How to reference**

In order to correctly reference this scholarly work, feel free to copy and paste the following:

Chin-Yin Chen, I-Ming Chen and Chi-Cheng Cheng (2011). Integrated Mechatronic Design for Servo Mechanical Systems, Advances in Mechatronics, Prof. Horacio Martinez-Alfaro (Ed.), ISBN: 978-953-307-373-6, InTech, Available from: <http://www.intechopen.com/books/advances-in-mechatronics/integrated-mechatronic-design-for-servo-mechanical-systems>

**INTECH**  
open science | open minds

#### **InTech Europe**

University Campus STeP Ri  
Slavka Krautzeka 83/A  
51000 Rijeka, Croatia  
Phone: +385 (51) 770 447  
Fax: +385 (51) 686 166  
[www.intechopen.com](http://www.intechopen.com)

#### **InTech China**

Unit 405, Office Block, Hotel Equatorial Shanghai  
No.65, Yan An Road (West), Shanghai, 200040, China  
中国上海市延安西路65号上海国际贵都大饭店办公楼405单元  
Phone: +86-21-62489820  
Fax: +86-21-62489821

© 2011 The Author(s). Licensee IntechOpen. This chapter is distributed under the terms of the [Creative Commons Attribution-NonCommercial-ShareAlike-3.0 License](#), which permits use, distribution and reproduction for non-commercial purposes, provided the original is properly cited and derivative works building on this content are distributed under the same license.

IntechOpen

IntechOpen