

# We are IntechOpen, the world's leading publisher of Open Access books Built by scientists, for scientists

4,400

Open access books available

117,000

International authors and editors

130M

Downloads

Our authors are among the

154

Countries delivered to

TOP 1%

most cited scientists

12.2%

Contributors from top 500 universities



WEB OF SCIENCE™

Selection of our books indexed in the Book Citation Index  
in Web of Science™ Core Collection (BKCI)

Interested in publishing with us?  
Contact [book.department@intechopen.com](mailto:book.department@intechopen.com)

Numbers displayed above are based on latest data collected.  
For more information visit [www.intechopen.com](http://www.intechopen.com)



# The Application of RFID in Automatic Feeding Machine for Single Daily Cow

Zhijiang Ni, Zhenjiang Gao and Hai Lin  
China Agricultural University  
China

## 1. Introduction

### Chapter Objectives

In this chapter, you'll be able to do the following:

- You'll know why the identification of single daily cow is needed
- The RFID device used in this research
- The communication between RFID and PC, between RFID and MCU
- The good effect due to the technology (experiment)

## 2. Why the identification of single daily cow is needed

Daily cow is one kind of ruminant animal, whose rumen plays an important role in the digestive process. There are many kinds of microbes in the lumen. Actually it is these microbes that play a crucial part for the digestion. These microbes are sensitive to the pH value in the rumen environment. To keep these microbes be in active status, the pH value should be kept at stable (the pH range should be 6.4~6.8). The studies show that the pH value in the rumen is relative with the amount of the concentrated feed. So we need control the amount of the concentrated feed that each daily cow got. This process involves the feeding based on a single daily cow. To realize this process, we need to identify the daily cow, and then give it the amount of concentrated feed that it needs. This process could be realized by the application of RFID system.

Ni (2009) designed an intelligent moving precise feeding machine for single dairy cow. An RFID system was equipped on this machine, which can move and identify the single dairy cow, and then give it the amount of the concentrated feed needed. The schematic figure is showed in Fig.1.

Voulodimos (2010) established a complete farm management system based on animal identification using RFID. This system contains various kinds of workstations, such as desktop computers (servers, database), laptops, handheld mobile devices, and a number of different subsystems. Fig. 2 shows the main subsystems: the central database, the local database and the mobile – RFID subsystem.

The central database system (left down in Fig.2) is used to store all information related to the management of animal tracking and monitoring at central level.

The local database system (right-down in Fig.2) is based on an animal data management application, such as tracking of animal vaccination, tracking of animals' diet.

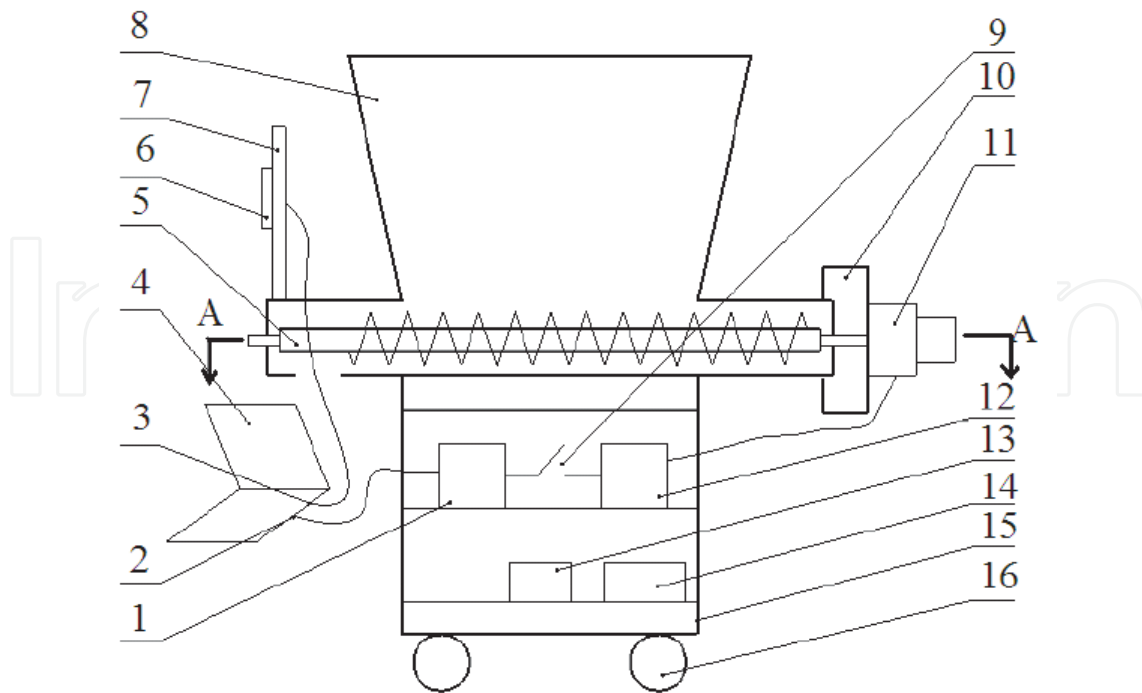

1-MCU, 2-First Serial Port, 3-Second Serial Port, 4-PC, 5-Auger, 6-RFID system, 7-Board for RFID, 8-Feed Bin, 9-Switch, 10-Board for Motor, 11-Motor, 12-Motor Actiyator, 13-Voltage Transfer Device, 14-Battery, 15-Frame, 16-Moving Device

Fig. 1. Schematic for Feeding Machine (Ni,2009)

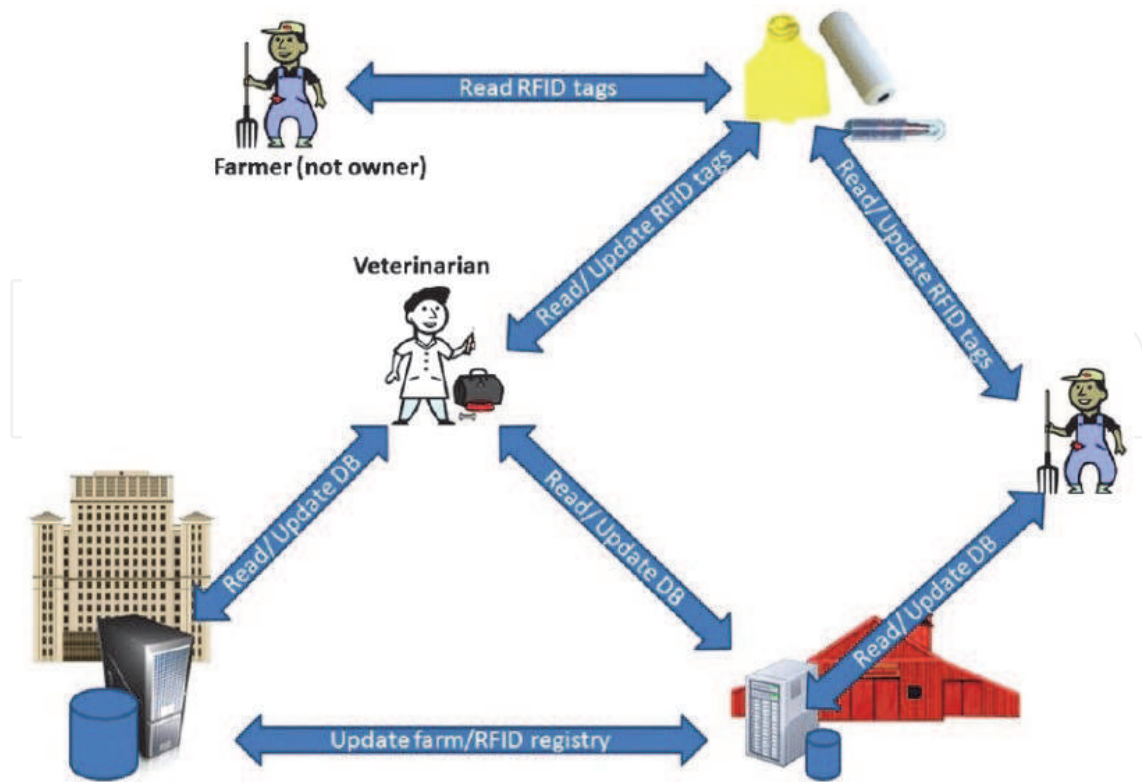

Fig. 2. Platform architecture (Voulodinos, 2010)

### 3. The RFID device used in this research

RFID is the abbreviation for Radio Frequency Identification, which is a technology that utilizes communication through electromagnetic waves to exchange data between an object and a terminal to realize the purpose of identification.

A RFID system (Fig.3) typically comprises following three parts (Roberts, 2005):

- An RFID device (tag);
- A tag reader with an antenna and transceiver;
- A host system or connection to an enterprise system.



Fig. 3. A typical RFID system (Roberts, 2005)

In the research of Ni (2009) and Li (2010), the reader used is SMC-R134 (Fig. 4), and the tag is SMC-E1334 (Fig. 5). Both the reader and the tag are the product of SMARTCHIP MOCROELECTRONIC CORP (SMC) in Taiwan.



Fig. 4. SMC-R134 Reader (Ni, 2009)



Fig. 5. SMC-E1334 Tag(Ni, 2009)

The maximum identify distance for this RFID system is  $50\text{cm} \pm 10\%$ . The frequency is 134.2 kHz. The working voltage is DC 9V. The parameters are shown in table 1.

Name	Parameters
Type	SMC-R134
Frequency	AM 134.2 kHz
Voltage	$V_{CC} = 9\text{V}$
Current dissipation	Max: 200 mA (9V)
Induction distance	$50\text{cm} \pm 10\%$ , working with SMC-E1334 tag
Weight	$780\text{g} \pm 2\%$
Length	264 mm
Width	264 mm
Height	30 mm

Table 1. Parameters for SMC-R134 Reader (Ni, 2009)

There are ten pins for the reading head of SMC-R134 reader. The colors for each pin (from left to right) are: red, black, yellow, purple, gray, green, brown, white, blue and orange, which is shown in fig. 6. The function for each pin is shown in table 2.

Pins	Pin Color	Name	I/O	Sign	Min Value	Typical Value	Max Value	Instruction
PIN1	red	$V_{CC}$	I	$V_{CC}$	8V	9V	10V	Power
PIN2	black	GND	I	$V_{SS}$	-	-	-	Power
PIN3	yellow	Program1	I	$V_{i-H}$ $V_{i-L}$	$V_{CC}-0.2\text{V}$	$V_{CC}$ GND	$V_{CC}+0.2\text{V}$ $V_{SS}+0.2\text{V}$	Select mode
PIN4	purple	Program2	I	$V_{i-H}$ $V_{i-L}$	$V_{CC}-0.2\text{V}$	$V_{CC}$ GND	$V_{CC}+0.2\text{V}$ $V_{SS}+0.2\text{V}$	Select mode
PIN5	gray		O			$\pm 5\text{V}$	$\pm 8\text{V}$	Used to select magnetic emulation
PIN6	green	DATA1	O	$V_{o-H}$ $V_{o-L}$	$V_{CC}-0.2\text{V}$	$V_{CC}$ GND	$V_{CC}+0.2\text{V}$ $V_{SS}+0.2\text{V}$	Wiegand output
PIN7	brown	DATA0	O	$V_{o-H}$ $V_{o-L}$	$V_{CC}-0.2\text{V}$	$V_{CC}$ GND	$V_{CC}+0.2\text{V}$ $V_{SS}+0.2\text{V}$	Wiegand output
PIN8	white							
PIN9	blue	RS232	O			$\pm 5\text{V}$	$\pm 8\text{V}$	RS232
PIN10	orange	For Customer	I	$V_{i-H}$ $V_{i-L}$	$V_{CC}-0.2\text{V}$	$V_{CC}$ GND	$V_{CC}+0.2\text{V}$ $V_{SS}+0.2\text{V}$	Connected GND to Light orange LED

Table 2. The function for each I/O pin (Li, 2010)

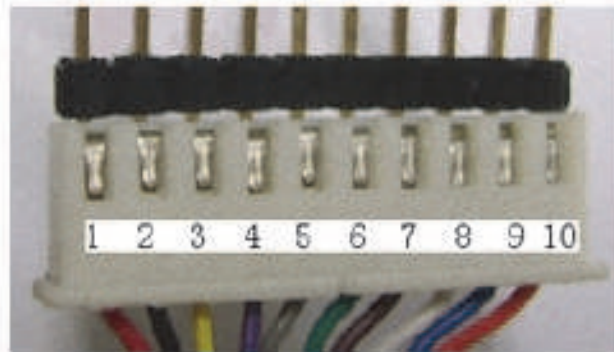

Fig. 6. I/O pins for SMC-R134 (Ni, 2009)

There are two types of output format: RS232 and Wiegand. Ni (2009) used RS232 format to establish the communication between RFID and PC. Li (2010) used Wiegand format to establish the communication between RFID and MCU.

#### 4. The communication between RFID and PC, between RFID and MCU

##### 4.1 The communication between RFID and PC

Ni (2009) used visual basic 2005 (VB 2005) as the software to communicate RFID with PC. To realize this objective, RS232 output format was used. The function of ReadExisting() was used to read the data sent by RFID reader. Before doing this, we need to establish the serial port object in VB 2005. The block diagram of establishing serial port object is shown in Fig 7.

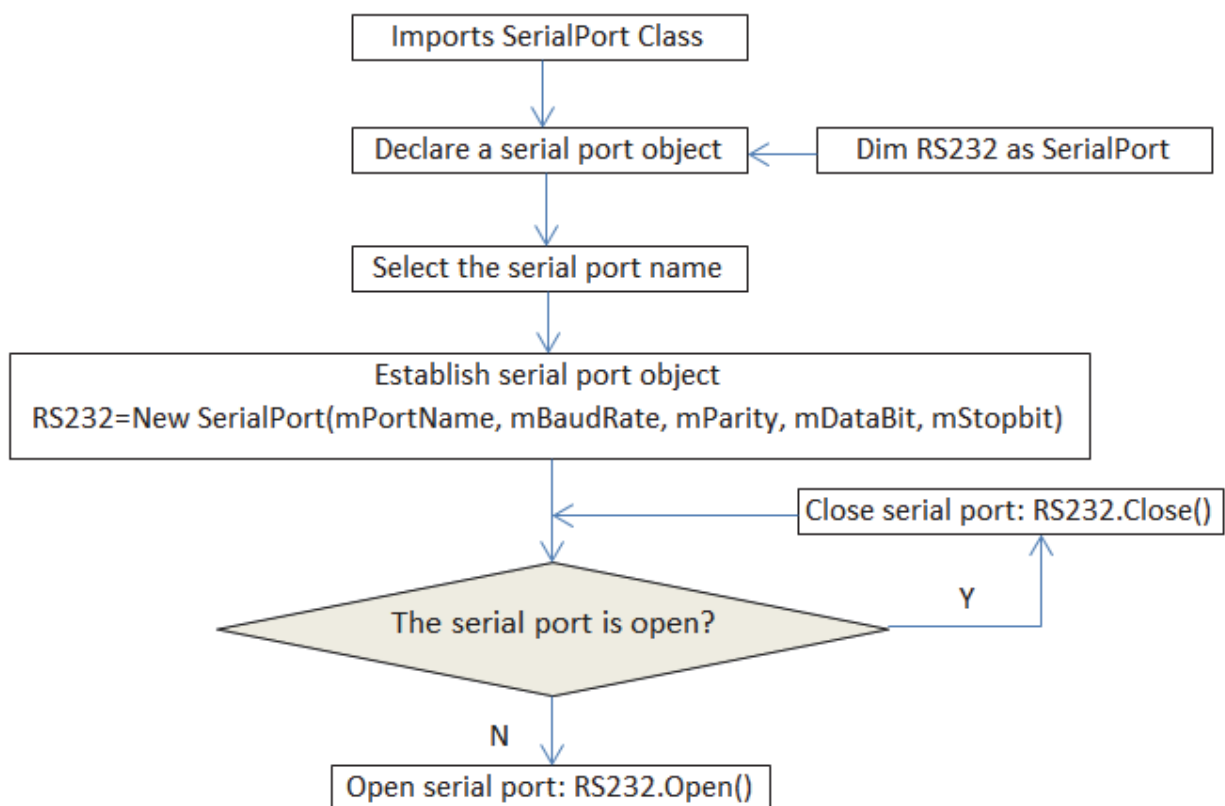

Fig. 7. The block diagram of establishing serial port object (Ni, 2009)



**4.2 The communication between RFID and MCU**

Li (2010) used Wiegand output format to establish the communication between RFID and MCU. This can realize the automatic control through only RFID and MCU without the help of computer. So the cost was minimized.

The software developed by Ni (2009) can be used as post processing tool to establish the dairy cow information system. The cow information, such as, ID number, weight, age, milk production, were recorded into the database. The ID number was gotten through the communication of RFID and PC. Then these ID numbers can be exported to the MCU to establish the communication between RFID and MCU.

Li (2010) imported two external interrupts to read the tag number. Once the tag number is matched with one of the ID stored in MCU, the single cow will be identified, and the cow's information will show in the LCD screen. The block diagram of communication between RFID and MCU is shown in Fig 8.

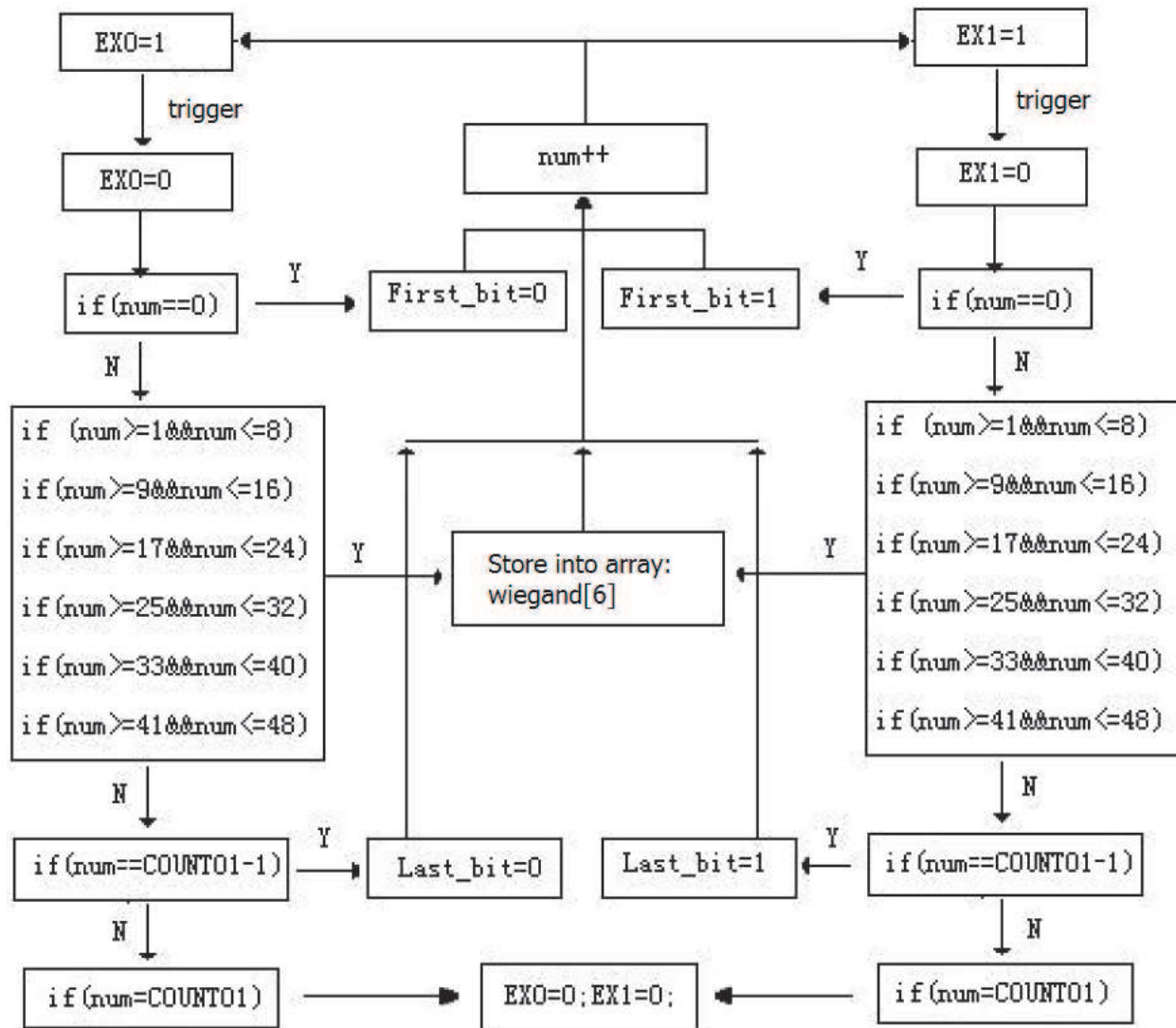

Fig. 8. The block diagram of communication between RFID and MCU (Li, 2010)

## 5. The good effect due to the technology (experiment)

Gao (2008) invented one kind of intelligent precise feeding machine. This machine was used in the research of Ni (2009) and Li (2010). This machine was equipped with the SMC-R134 reader. And the experimental cow was worn an ear tag (SMC-E1334). The feeding machine is shown in Fig 9.

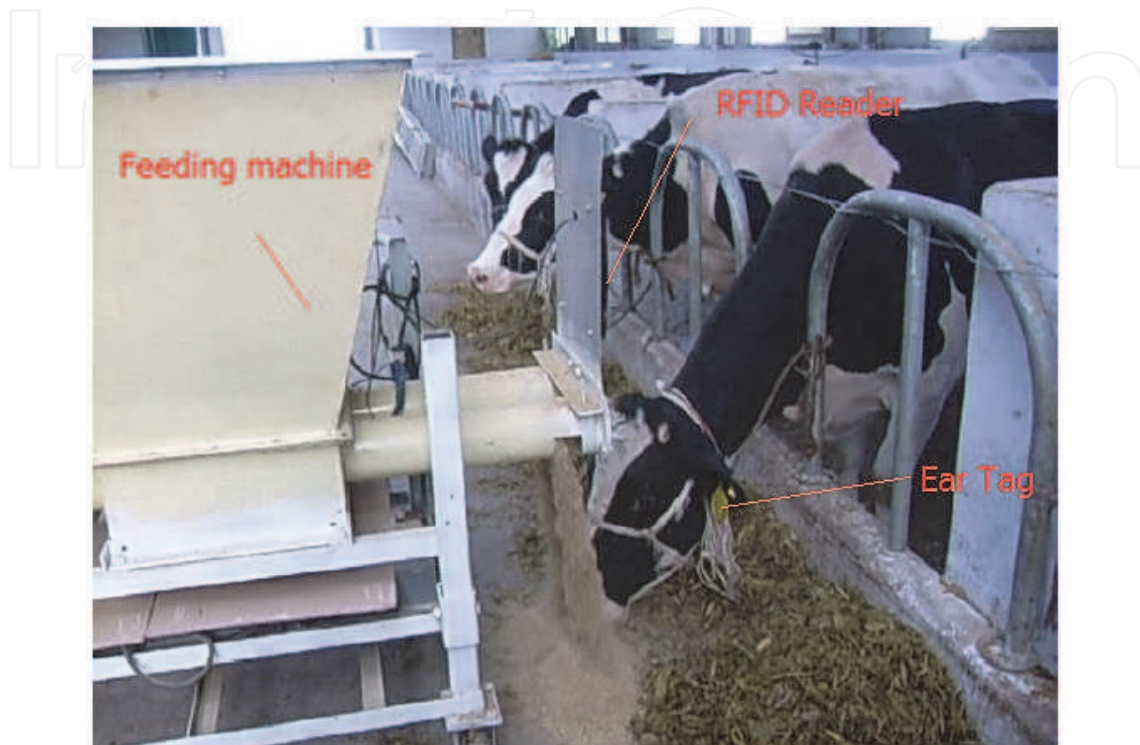

Fig. 9. Feeding Machine (Ni, 2009)

Ni (2009) did a basic experiment using this machine. Ten dairy cows were fed for one month. The concentrated feed was given by this machine based on the cow information (ID number, weight, age, milk production, etc). The result showed that the milk production can be added 4kg per day per cow.

Li (2010) did a deep experiment using this machine. 70 dairy cows were used. Besides the milk production, milk fat content and protein content were also be evaluated. The improved milk production is 3.9 kg, the average milk fat content is 3.74%, and the average protein content is 2.98%.

## 6. Summary

In this chapter, we introduced the application of RFID in daily cow industry. Firstly, we gave a brief introduction of why the identification of single daily cow is needed. By using RFID technology, the single daily cow information can be stored in database system. Through the tag ID, we can know the information about the cow. Later, we introduced one kind of RFID device used in the research. The communications between RFID and PC, RFID and MCU were established. Finally, two experiments based on the machine invented by Gao (2008) were introduced. The experimental results was good. The milk production were improved about 4kg per day for per cow.



## 7. Abbreviations and symbols

- RFID: Radio Frequency Identification
- PC: Personal Computer
- MCU: Micro Controller Unit

## 8. Reference

- [1] Zhijiang Ni. 2009. *Design and Experiment on Intelligent Moving Precise Feeding Machine for Single Dairy Cow*. Master's dissertation. China Agricultural University, Beijing, China.
- [2] Zhijiang Ni. 2009. *Intelligent Feeding Information System for Single Dairy Cow*. Software. China Agricultural University, Beijing, China. Software Register Number: 2009SRBJ0356.
- [3] A. S. Voulodimos, C. Z. Patrikakis, A. B. Sideridis, V. A. Ntafis, E. M. Xylouri. 2010. *A complete farm management system based on animal identification using RFID*. *Computers and Electronics in Agriculture*, Volume 70, Issue 2, Pages 380-388
- [4] C.M. Roberts. 2005. *Radio frequency identification (RFID)*. *Computers & Security*, Volume 25, Issue 1, February 2006, Pages 18-26
- [5] Jicheng Li. 2010. *Design and Experiment on Auto-Control System of Dairy Cow Precising Feeding Equipment based on MCU*. Master's dissertation. China Agricultural University, Beijing, China.
- [6] Zhenjiang Gao, Zhijiang Ni, Za Kan. 2008. *One kind of intelligent precise feeding machine*. *China patent*. Patent id: 200810239151.

IntechOpen



## **Deploying RFID - Challenges, Solutions, and Open Issues**

Edited by Dr. Cristina Turcu

ISBN 978-953-307-380-4

Hard cover, 382 pages

**Publisher** InTech

**Published online** 17, August, 2011

**Published in print edition** August, 2011

Radio frequency identification (RFID) is a technology that is rapidly gaining popularity due to its several benefits in a wide area of applications like inventory tracking, supply chain management, automated manufacturing, healthcare, etc. The benefits of implementing RFID technologies can be seen in terms of efficiency (increased speed in production, reduced shrinkage, lower error rates, improved asset tracking etc.) or effectiveness (services that companies provide to the customers). Leading to considerable operational and strategic benefits, RFID technology continues to bring new levels of intelligence and information, strengthening the experience of all participants in this research domain, and serving as a valuable authentication technology. We hope this book will be useful for engineers, researchers and industry personnel, and provide them with some new ideas to address current and future issues they might be facing.

### **How to reference**

In order to correctly reference this scholarly work, feel free to copy and paste the following:

Zhijiang Ni, Zhenjiang Gao and Hai Lin (2011). The Application of RFID in Automatic Feeding Machine for Single Daily Cow, Deploying RFID - Challenges, Solutions, and Open Issues, Dr. Cristina Turcu (Ed.), ISBN: 978-953-307-380-4, InTech, Available from: <http://www.intechopen.com/books/deploying-rfid-challenges-solutions-and-open-issues/the-application-of-rfid-in-automatic-feeding-machine-for-single-daily-cow>

**INTECH**  
open science | open minds

### **InTech Europe**

University Campus STeP Ri  
Slavka Krautzeka 83/A  
51000 Rijeka, Croatia  
Phone: +385 (51) 770 447  
Fax: +385 (51) 686 166  
[www.intechopen.com](http://www.intechopen.com)

### **InTech China**

Unit 405, Office Block, Hotel Equatorial Shanghai  
No.65, Yan An Road (West), Shanghai, 200040, China  
中国上海市延安西路65号上海国际贵都大饭店办公楼405单元  
Phone: +86-21-62489820  
Fax: +86-21-62489821

© 2011 The Author(s). Licensee IntechOpen. This chapter is distributed under the terms of the [Creative Commons Attribution-NonCommercial-ShareAlike-3.0 License](#), which permits use, distribution and reproduction for non-commercial purposes, provided the original is properly cited and derivative works building on this content are distributed under the same license.

IntechOpen

IntechOpen