

We are IntechOpen, the world's leading publisher of Open Access books Built by scientists, for scientists

4,400

Open access books available

117,000

International authors and editors

130M

Downloads

Our authors are among the

154

Countries delivered to

TOP 1%

most cited scientists

12.2%

Contributors from top 500 universities



WEB OF SCIENCE™

Selection of our books indexed in the Book Citation Index
in Web of Science™ Core Collection (BKCI)

Interested in publishing with us?
Contact book.department@intechopen.com

Numbers displayed above are based on latest data collected.
For more information visit www.intechopen.com



Robust Delay-Independent/Dependent Stabilization of Uncertain Time-Delay Systems by Variable Structure Control

Elbrous M. Jafarov

*Faculty of Aeronautics and Astronautics, Istanbul Technical University
Turkey*

1. Introduction

It is well known that many engineering control systems such as conventional oil-chemical industrial processes, nuclear reactors, long transmission lines in pneumatic, hydraulic and rolling mill systems, flexible joint robotic manipulators and machine-tool systems, jet engine and automobile control, human-autopilot systems, ground controlled satellite and networked control and communication systems, space autopilot and missile-guidance systems, etc. contain some time-delay effects, model uncertainties and external disturbances. These processes and plants can be modeled by some uncertain dynamical systems with state and input delays. The existence of time-delay effects is frequently a source of instability and it degrades the control performances. The stabilization of systems with time-delay is not easier than that of systems without time-delay. Therefore, the stability analysis and controller design for uncertain systems with delay are important both in theory and in practice. The problem of robust stabilization of uncertain time-delay systems by various types of controllers such as PID controller, Smith predictor, and time-delay controller, recently, sliding mode controllers have received considerable attention of researchers. However, in contrast to variable structure systems without time-delay, there is relatively no large number of papers concerning the sliding mode control of time-delay systems. Generally, stability analysis can be divided into two categories: delay-independent and delay-dependent. It is worth to mention that delay-dependent conditions are less conservative than delay-independent ones because of using the information on the size of delays, especially when time-delays are small. As known from (Utkin, 1977)-(Jafarov, 2009) etc. sliding mode control has several useful advantages, e.g. fast response, good transient performance, and robustness to the plant parameter variations and external disturbances. For this reason, now, sliding mode control is considered as an efficient tool to design of robust controllers for stabilization of complex systems with parameter perturbations and external disturbances. Some new problems of the sliding mode control of time-delay systems have been addressed in papers (Shyu & Yan, 1993)-(Jafarov, 2005). Shyu and Yan (Shyu & Yan, 1993) have established a new sufficient condition to guarantee the robust stability and β -stability for uncertain systems with single time-delay. By these conditions a variable structure controller is designed to stabilize the time-delay systems with uncertainties. Koshkoei and Zinober (Koshkouei & Zinober, 1996) have designed a new

sliding mode controller for MIMO canonical controllable time-delay systems with matched external disturbances by using Lyapunov-Krasovskii functional. Robust stabilization of time-delay systems with uncertainties by using sliding mode control has been considered by Luo, De La Sen and Rodellar (Luo et al., 1997). However, disadvantage of this design approach is that, a variable structure controller is not simple. Moreover, equivalent control term depends on unavailable external disturbances. Li and DeCarlo (Li & De Carlo, 2003) have proposed a new robust four terms sliding mode controller design method for a class of multivariable time-delay systems with unmatched parameter uncertainties and matched external disturbances by using the Lyapunov-Krasovskii functional combined by LMI's techniques. The behavior and design of sliding mode control systems with state and input delays are considered by Perruquetti and Barbot (Perruquetti & Barbot, 2002) by using Lyapunov-Krasovskii functional.

Four-term robust sliding mode controllers for matched uncertain systems with single or multiple, constant or time varying state delays are designed by Gouaisbaut, Dambrine and Richard (Gouaisbaut et al., 2002) by using Lyapunov-Krasovskii functionals and Lyapunov-Razumikhin function combined with LMI's techniques. The five terms sliding mode controllers for time-varying delay systems with structured parameter uncertainties have been designed by Fridman, Gouaisbaut, Dambrine and Richard (Fridman et al., 2003) via descriptor approach combined by Lyapunov-Krasovskii functional method. In (Cao et al., 2007) some new delay-dependent stability criteria for multivariable uncertain networked control systems with several constant delays based on Lyapunov-Krasovskii functional combined with descriptor approach and LMI techniques are developed by Cao, Zhong and Hu. A robust sliding mode control of single state delayed uncertain systems with parameter perturbations and external disturbances is designed by Jafarov (Jafarov, 2005). In survey paper (Hung et al., 1993) the various type of reaching conditions, variable structure control laws, switching schemes and its application in industrial systems is reported by J. Y. Hung, Gao and J.C. Hung. The implementation of a tracking variable structure controller with boundary layer and feed-forward term for robotic arms is developed by Xu, Hashimoto, Slotine, Arai and Harashima (Xu et al., 1989). A new fast-response sliding mode current controller for boost-type converters is designed by Tan, Lai, Tse, Martinez-Salamero and Wu (Tan et al., 2007). By constructing new types of Lyapunov functionals and additional free-weighting matrices, some new less conservative delay-dependent stability conditions for uncertain systems with constant but unknown time-delay have been presented in (Li et al., 2010) and its references.

Motivated by these investigations, the problem of sliding mode controller design for uncertain multi-input systems with several fixed state delays for delay-independent and delay-dependent cases is addressed in this chapter. A new combined sliding mode controller is considered and it is designed for the stabilization of perturbed multi-input time-delay systems with matched parameter uncertainties and external disturbances. Delay-independent/dependent stability and sliding mode existence conditions are derived by using Lyapunov-Krasovskii functional and Lyapunov function method and formulated in terms of LMI. Delay bounds are determined from the improved stability conditions. In practical implementation chattering problem can be avoided by using saturation function (Hung et al., 1993), (Xu et al., 1989).

Five numerical examples with simulation results are given to illustrate the usefulness of the proposed design method.

2. System description and assumptions

Let us consider a multi-input state time-delay systems with matched parameter uncertainties and external disturbances described by the following state-space equation:

$$\begin{aligned} \dot{x}(t) &= (A_0 + \Delta A_0)x(t) + (A_1 + \Delta A_1)x(t - h_1) + \dots + (A_N + \Delta A_N)x(t - h_N) + Bu(t) + Df(t), \quad t > 0 \\ x(t) &= \phi(t), \quad -h \leq t \leq 0 \end{aligned} \quad (1)$$

where $x(t) \in R^n$ is the measurable state vector, $u(t) \in R^m$ is the control input, A_0, A_1, \dots, A_N and B are known constant matrices of appropriate dimensions, with B of full rank, $h = \max[h_1, h_2, \dots, h_N], h_i > 0$, h_1, h_2, \dots, h_N are known constant time-delays, $\phi(t)$ is a continuous vector-valued initial function in $-h \leq t \leq 0$; $\Delta A_0, \Delta A_1, \dots, \Delta A_N$ and D are the parameter uncertainties, $f(t)$ is unknown but norm-bounded external disturbances.

Taking known advantages of sliding mode, we want to design a simple suitable sliding mode controller for stabilization of uncertain time-delay system (1).

We need to make the following conventional assumptions for our design problem.

Assumption 1:

- (A_0, B) is stabilizable;
- The parameter uncertainties and external disturbances are matched with the control input, i.e. there exist matrices $E_0(t), E(t), E_1(t), \dots, E_N(t)$, such that:

$$\Delta A_0(t) = BE_0(t) ; A_1(t) = BE_1(t) ; \dots, \Delta A_N(t) = BE_N(t) ; D(t) = BE(t) \quad (2)$$

with norm-bounded matrices:

$$\begin{aligned} \max_t \|\Delta E_0(t)\| &\leq \alpha_0 ; \max_t \|\Delta E_1(t)\| \leq \alpha_1 ; \dots, \max_t \|\Delta E_N(t)\| \leq \alpha_N \\ \|E(t)\| &= \alpha \\ \|G\| &= g \\ \|f(t)\| &\leq f_0 \end{aligned} \quad (3)$$

where $\alpha_0, \alpha_1, \alpha_2, \dots, \alpha_n, g$ and f_0 are known positive scalars.

The control goal is to design a combined variable structure controller for robust stabilization of time-delay system (1) with matched parameter uncertainties and external disturbances.

3. Control law and sliding surface

To achieve this goal, we form the following type of combined variable structure controller:

$$u(t) = u_{lin}(t) + u_{eq}(t) + u_{vs}(t) + u_r(t) \quad (4)$$

where

$$u_{lin}(t) = -Gx(t) \quad (5)$$

$$u_{eq}(t) = -(CB)^{-1} [CA_0x(t) + CA_1x(t - h_1) + \dots + CA_Nx(t - h_N)] \quad (6)$$

$$u_{vs}(t) = -\left[k_0 \|x(t)\| + k_1 \|x(t-h_1)\| + \dots + k_N \|x(t-h_N)\| \right] \frac{s(t)}{\|s(t)\|} \quad (7)$$

$$u_r = -\delta \frac{s(t)}{\|s(t)\|} \quad (8)$$

where k_0, k_1, \dots, k_N and δ are the scalar gain parameters to be selected; G is a design matrix; $(CB)^{-1}$ is a non-singular $m \times m$ matrix. The sliding surface on which the perturbed time-delay system states must be stable is defined as a linear function of the undelayed system states as follows:

$$s(t) = \Gamma Cx(t) \quad (9)$$

where C is a $m \times n$ gain matrix of full rank to be selected; Γ is chosen as identity $m \times m$ matrix that is used to diagonalize the control.

Equivalent control term (6) for non-perturbed time-delay system is determined from the following equations:

$$\dot{s}(t) = C\dot{x}(t) = CA_0x(t) + CA_1x(t-h_1) + \dots + CA_Nx(t-h_N) + CBu(t) = 0 \quad (10)$$

Substituting (6) into (1) we have a non-perturbed or ideal sliding time-delay motion of the nominal system as follows:

$$\dot{x}(t) = \bar{A}_0x(t) + \bar{A}_1x(t-h_1) + \dots + \bar{A}_Nx(t-h_N) \quad (11)$$

where

$$(CB)^{-1}C = G_{eq}, A_0 - BG_{eq}A_0 = \bar{A}_0, A_1 - BG_{eq}A_1 = \bar{A}_1, \dots, A_N - BG_{eq}A_N = \bar{A}_N \quad (12)$$

Note that, constructed sliding mode controller consists of four terms:

1. The linear control term is needed to guarantee that the system states can be stabilized on the sliding surface;
2. The equivalent control term for the compensation of the nominal part of the perturbed time-delay system;
3. The variable structure control term for the compensation of parameter uncertainties of the system matrices;
4. The min-max or relay term for the rejection of the external disturbances.

Structure of these control terms is typical and very simple in their practical implementation. The design parameters $G, C, k_0, k_1, \dots, k_N, \delta$ of the combined controller (4) for delay-independent case can be selected from the sliding conditions and stability analysis of the perturbed sliding time-delay system.

However, in order to make the delay-dependent stability analysis and choosing an appropriate Lyapunov-Krasovskii functional first let us transform the nominal sliding time-delay system (11) by using the Leibniz-Newton formula. Since $x(t)$ is continuously differentiable for $t \geq 0$, using the Leibniz-Newton formula, the time-delay terms can be presented as:

$$x(t-h_1) = x(t) - \int_{t-h_1}^t \dot{x}(\theta) d\theta, \dots, x(t-h_N) = x(t) - \int_{t-h_N}^t \dot{x}(\theta) d\theta \quad (13)$$

Then, the system (11) can be rewritten as

$$\dot{x}(t) = (\bar{A}_0 + \bar{A}_1 + \dots + \bar{A}_N)x(t) - \bar{A}_1 \int_{t-h_1}^t \dot{x}(\theta)d\theta - \dots - \bar{A}_N \int_{t-h_N}^t \dot{x}(\theta)d\theta \tag{14}$$

Substituting again (11) into (14) yields:

$$\begin{aligned} \dot{x}(t) &= (\bar{A}_0 + \bar{A}_1 + \dots + \bar{A}_N)x(t) - \bar{A}_1 \int_{t-h_1}^t [\bar{A}_0x(\theta) + \bar{A}_1x(\theta-h_1) + \dots + \bar{A}_Nx(\theta-h_N)]d\theta \\ &\quad - \dots - \bar{A}_N \int_{t-h_N}^t [\bar{A}_0x(\theta) + \bar{A}_1x(\theta-h_1) + \dots + \bar{A}_Nx(\theta-h_N)]d\theta \\ &= (\bar{A}_0 + \bar{A}_1 + \dots + \bar{A}_N)x(t) - \bar{A}_1\bar{A}_0 \int_{t-h_1}^t x(\theta)d\theta - \bar{A}_1^2 \int_{t-h_1}^t x(\theta-h_1)d\theta - \dots - \bar{A}_1\bar{A}_N \int_{t-h_1}^t x(\theta-h_N)d\theta \\ &\quad - \dots - \bar{A}_N\bar{A}_0 \int_{t-h_N}^t x(\theta)d\theta - \bar{A}_N\bar{A}_1 \int_{t-h_N}^t x(\theta-h_1)d\theta - \dots - \bar{A}_N^2 \int_{t-h_N}^t x(\theta-h_N)d\theta \end{aligned} \tag{15}$$

Then in adding to (15) the perturbed sliding time-delay system with control action (4) or overall closed loop system can be formulated as:

$$\begin{aligned} \dot{x}(t) &= (\tilde{A}_0 + \bar{A}_1 + \dots + \bar{A}_N)x(t) - \bar{A}_1\bar{A}_0 \int_{t-h_1}^t x(\theta)d\theta - \bar{A}_1^2 \int_{t-h_1}^t x(\theta-h_1)d\theta \\ &\quad - \dots - \bar{A}_1\bar{A}_N \int_{t-h_1}^t x(\theta-h_N)d\theta - \dots - \bar{A}_N\bar{A}_0 \int_{t-h_N}^t x(\theta)d\theta - \bar{A}_N\bar{A}_1 \int_{t-h_N}^t x(\theta-h_1)d\theta \\ &\quad - \dots - \bar{A}_N^2 \int_{t-h_N}^t x(\theta-h_N)d\theta + \Delta A_0x(t) \\ &\quad + \Delta A_1x(t-h_1) + \dots + \Delta A_Nx(t-h_N) \\ &\quad - B[k_0\|x(t)\| + k_1\|x(t-h_1)\| + \dots + k_N\|x(t-h_N)\|] \frac{s(t)}{\|s(t)\|} - B\delta \frac{s(t)}{\|s(t)\|} + Df(t) \end{aligned} \tag{16}$$

where $\tilde{A}_0 = \bar{A}_0 - BG$, the gain matrix G can be selected such that \tilde{A}_0 has the desirable eigenvalues.

The design parameters $G, C, k_0, k_1, \dots, k_N, \delta$ of the combined controller (4) for delay-dependent case can be selected from the sliding conditions and stability analysis of the perturbed sliding time-delay system (16).

4. Robust delay-independent stabilization

In this section, the existence condition of the sliding manifold and delay-independent stability analysis of perturbed sliding time-delay systems are presented.

4.1 Robust delay-independent stabilization on the sliding surface

In this section, the sliding manifold is designed so that on it or in its neighborhood in different from existing methods the perturbed sliding time-delay system (1),(4) is globally

asymptotically stable with respect to state coordinates. The perturbed stability results are formulated in the following theorem.

Theorem 1: Suppose that Assumption 1 holds. Then the multivariable time-delay system (1) with matched parameter perturbations and external disturbances driven by combined controller (4) and restricted to the sliding surface $s(t)=0$ is robustly globally asymptotically delay-independent stable with respect to the state variables, if the following LMI conditions and parameter requirements are satisfied:

$$H = \begin{bmatrix} \widetilde{A}_0^T P + P \widetilde{A}_0 + R_1 + \dots + R_N & P \overline{A}_1 & \dots & P \overline{A}_N \\ (P \overline{A}_1)^T & -R_1 & \dots & 0 \\ \vdots & \vdots & \ddots & \vdots \\ (P \overline{A}_N)^T & 0 & \dots & -R_N \end{bmatrix} < 0 \quad (17)$$

$$CB = B^T P B > 0 \quad (18)$$

$$k_0 = \alpha_0; k_1 = \alpha_1; \dots; k_N = \alpha_N \quad (19)$$

$$\delta \geq f_0 \quad (20)$$

where P, R_1, \dots, R_N are some symmetric positive definite matrices which are a feasible solution of LMI (17) with (18); $\widetilde{A}_0 = \overline{A}_0 - BG$ in which a gain matrix G can be assigned by pole placement such that \widetilde{A}_0 has some desirable eigenvalues.

Proof: Choose a Lyapunov-Krasovskii functional candidate as follows:

$$V = x^T(t) P x(t) + \sum_{i=1}^N \int_{t-h_i}^t x^T(\theta) R_i x(\theta) d\theta \quad (21)$$

The time-derivative of (21) along the state trajectories of time-delay system (1), (4) can be calculated as follows:

$$\begin{aligned} \dot{V} &= 2x^T(t) P [A_0 x(t) + A_1 x(t-h_1) + \dots + A_N x(t-h_N) + \Delta A_0 x(t) + \Delta A_1 x(t-h_1) \\ &\quad + \dots + \Delta A_N x(t-h_N) + Bu(t) + Df(t)] \\ &\quad + x^T(t) R_1 x(t) - x^T(t-h_1) R_1 x(t-h_1) + \dots + x^T(t) R_N x(t) - x^T(t-h_N) R_N x(t-h_N) \\ &= 2x^T(t) P \overline{A}_0 x(t) + 2x^T(t) P \overline{A}_1 x(t-h_1) + \dots + 2x^T(t) P \overline{A}_N x(t-h_N) + 2x^T(t) P B E_0 x(t) \\ &\quad + 2x^T(t) P B E_1 x(t-h_1) + \dots + 2x^T(t) P B E_N x(t-h_N) \\ &\quad - 2x^T(t) P B [k_0 \|x(t)\| + k_1 \|x(t-h_1)\| + \dots + k_N \|x(t-h_N)\|] \frac{s(t)}{\|s(t)\|} \\ &\quad - 2x^T(t) P B G x(t) - 2\delta x^T(t) P B \frac{s(t)}{\|s(t)\|} + 2x^T(t) P B E f(t) \\ &\quad + x^T(t) (R_1 + \dots + R_N) x(t) - x^T(t-h_1) R_1 x(t-h_1) - \dots - x^T(t-h_N) R_N x(t-h_N) \end{aligned}$$

Since $x^T(t) P B = s^T(t)$, then we obtain:

$$\begin{aligned}
 \dot{V} \leq & x^T(t) \left[\widetilde{A}_0^T P + P \widetilde{A}_0 + R_1 + \dots + R_N \right] x(t) \\
 & + 2x^T(t) P \overline{A}_1 x(t-h_1) + \dots + 2x^T(t) P \overline{A}_N x(t-h_N) \\
 & - x^T(t-h_1) R_1 x(t-h_1) - \dots - x^T(t-h_N) R_N x(t-h_N) \\
 & + 2s^T(t) E_0 x(t) + 2s^T(t) E_1 x(t-h_1) + \dots + 2s^T(t) E_N x(t-h_N) \\
 & + 2s^T(t) E f(t) - 2s^T(t) [k_0 \|x(t)\| + k_1 \|x(t-h_1)\| + \dots + k_N \|x(t-h_N)\|] \frac{s(t)}{\|s(t)\|} - 2\delta s^T(t) \frac{s(t)}{\|s(t)\|} \quad (22) \\
 \leq & \begin{bmatrix} x(t) \\ x(t-h_1) \\ \vdots \\ x(t-h_N) \end{bmatrix}^T \begin{bmatrix} \widetilde{A}_0^T P + P \widetilde{A}_0 + R_1 + \dots + R_N & P \overline{A}_1 & \dots & P \overline{A}_N \\ & (P \overline{A}_1)^T & & \\ & \vdots & & \\ & (P \overline{A}_N)^T & & \end{bmatrix} \begin{bmatrix} x(t) \\ x(t-h_1) \\ \vdots \\ x(t-h_N) \end{bmatrix} \\
 & - [(k_0 - \alpha_0) \|x(t)\| \|s(t)\| + (k_1 - \alpha_1) \|x(t-h_1)\| \|s(t)\| + \dots + (k_N - \alpha_N) \|x(t-h_N)\| \|s(t)\|] \\
 & - (\delta - f_0) \|s(t)\|
 \end{aligned}$$

Since (17)-(20) hold, then (22) reduces to:

$$\dot{V} \leq z^T(t) H z(t) < 0 \quad (23)$$

where $z^T(t) = [x(t) x(t-h_1) \dots x(t-h_N)]$.

Therefore, we can conclude that the perturbed time-delay system (1), (4) is robustly globally asymptotically delay-independent stable with respect to the state coordinates. Theorem 1 is proved.

4.2 Existence conditions

The final step of the control design is the derivation of the sliding mode existence conditions or the reaching conditions for the perturbed time-delay system (1),(4) states to the sliding manifold in finite time. These results are summarized in the following theorem.

Theorem 2: Suppose that Assumption 1 holds. Then the perturbed multivariable time-delay system (1) states with matched parameter uncertainties and external disturbances driven by controller (4) converge to the sliding surface $s(t)=0$ in finite time, if the following conditions are satisfied:

$$k_0 = \alpha_0 + g; k_1 = \alpha_1; \dots; k_N = \alpha_N \quad (24)$$

$$\delta \geq f_0 \quad (25)$$

Proof: Let us choose a modified Lyapunov function candidate as:

$$V = \frac{1}{2} s^T(t) (CB)^{-1} s(t) \quad (26)$$

The time-derivative of (26) along the state trajectories of time-delay system (1), (4) can be calculated as follows:

$$\begin{aligned}
\dot{V} &= s^T(t)(CB)^{-1}\dot{s}(t) = s^T(t)(CB)^{-1}C\dot{x}(t) \\
&= s^T(t)(CB)^{-1}C[A_0x(t) + A_1x(t-h_1) + \dots + A_Nx(t-h_N) \\
&\quad + \Delta A_0x(t) + \Delta A_1x(t-h_1) + \dots + \Delta A_Nx(t-h_N) + Bu(t) + Df(t)] \\
&= s^T(t)(CB)^{-1}[CA_0x(t) + CA_1x(t-h_1) + \dots + CA_Nx(t-h_N) \\
&\quad + CBE_0x(t) + CBE_1x(t-h_1) + \dots + CBE_Nx(t-h_N) \\
&\quad - CB((CB)^{-1}[CA_0x(t) + CA_1x(t-h) + \dots + CA_Nx(t-h_N)]) \\
&\quad - [k_0\|x(t)\| + k_1\|x(t-h_1)\| + \dots + k_N\|x(t-h_N)\|]\frac{s(t)}{\|s(t)\|} \\
&\quad - Gx(t) - \delta\frac{s(t)}{\|s(t)\|}] + CBEf(t) \\
&= s^T(t)[E_0x(t) + E_1x(t-h_1) + \dots + E_Nx(t-h_N)] \\
&\quad - [k_0\|x(t)\| + k_1\|x(t-h_1)\| + \dots + k_N\|x(t-h_N)\|]\frac{s(t)}{\|s(t)\|} \\
&\quad - Gx(t) - \delta\frac{s(t)}{\|s(t)\|} + Ef(t) \\
&\leq -[(k_0 - \alpha_0 - g)\|x(t)\|\|s(t)\| + (k_1 - \alpha_1)\|x(t-h_1)\|\|s(t)\| \\
&\quad + \dots + (k_N - \alpha_N)\|x(t-h_N)\|\|s(t)\|] - (\delta - f_0)\|s(t)\|
\end{aligned} \tag{27}$$

Since (24), (25) hold, then (27) reduces to:

$$\dot{V} = s^T(t)(CB)^{-1}\dot{s}(t) \leq -(\delta - f_0)\|s(t)\| \leq -\eta\|s(t)\| \tag{28}$$

where

$$\eta = \delta - f_0 \geq 0 \tag{29}$$

Hence we can evaluate that

$$\dot{V}(t) \leq -\eta\sqrt{\frac{2}{\lambda_{\min}(CB)^{-1}}}\sqrt{V(t)} \tag{30}$$

The last inequality (30) is known to prove the finite-time convergence of system (1), (4) towards the sliding surface $s(t)=0$ (Utkin, 1977), (Perruquetti & Barbot, 2002). Therefore, Theorem 2 is proved.

4.3 Numerical examples and simulation

In order to demonstrate the usefulness of the proposed control design techniques let us consider the following examples.

Example 1: Consider a networked control time-delay system (1), (4) with parameters taking from (Cao et al., 2007):

$$A_0 = \begin{bmatrix} -4 & 0 \\ -1 & -3 \end{bmatrix}, A_1 = \begin{bmatrix} -1.5 & 0 \\ -1 & -0.5 \end{bmatrix}, B = \begin{bmatrix} 2 \\ 2 \end{bmatrix} \tag{31}$$

$$\Delta A_0 = 0.5 \sin(t) A_0, \Delta A_1 = 0.5 \cos(t) A_1, f = 0.3 \sin(t)$$

The LMI stability and sliding mode existence conditions are computed by MATLAB programming (see Appendix 1) where LMI Control Toolbox is used. The computational results are following:

$$\begin{aligned} A_{0hat} &= \begin{bmatrix} -1.0866 & 1.0866 \\ 1.9134 & -1.9134 \end{bmatrix}; A_{1hat} = \begin{bmatrix} -0.1811 & 0.1811 \\ 0.3189 & -0.3189 \end{bmatrix} \\ G_1 &= \begin{bmatrix} 0.9567 & 1.2933 \end{bmatrix}; A_{0til} = \begin{bmatrix} -3.0000 & -1.5000 \\ 0.0000 & -4.5000 \end{bmatrix}; eigA_{0til} = \begin{bmatrix} -3.0000 \\ -4.5000 \end{bmatrix} \\ eigA_{0hat} &= \begin{bmatrix} 0.0000 \\ -3.0000 \end{bmatrix}; eigA_{1hat} = \begin{bmatrix} 0.0000 \\ -0.5000 \end{bmatrix} \\ lhs &= \begin{bmatrix} -1.8137 & 0.0020 & -0.1392 & 0.1392 \\ 0.0020 & -1.7813 & 0.1382 & -0.1382 \\ -0.1392 & 0.1382 & -1.7364 & 0.0010 \\ 0.1392 & -0.1382 & 0.0010 & -1.7202 \end{bmatrix}; eigsLHS = \begin{bmatrix} -2.0448 \\ -1.7952 \\ -1.7274 \\ -1.4843 \end{bmatrix} \\ P &= \begin{bmatrix} 0.6308 & -0.0782 \\ -0.0782 & 0.3891 \end{bmatrix}; eigP = \begin{bmatrix} 0.3660 \\ 0.6539 \end{bmatrix}; \\ R_1 &= \begin{bmatrix} 1.7364 & -0.0010 \\ -0.0010 & 1.7202 \end{bmatrix}; eigR_1 = \begin{bmatrix} 1.7202 \\ 1.7365 \end{bmatrix} \\ BTP &= [1.1052 \quad 0.6217]; BTPB = 3.4538 \\ invBTPB &= 0.2895; normG_1 = 1.6087 \\ k_0 &= 2.1087; k_1=0.5; \delta \geq 0.3; H < 0; \end{aligned}$$

The networked control time-delay system is robustly asymptotically delay-independent stable.

Example 2: Consider a time-delay system (1), (4) with parameters:

$$\begin{aligned} A_0 &= \begin{bmatrix} -1 & 0.7 \\ 0.3 & 1 \end{bmatrix}, A_1 = \begin{bmatrix} 0.1 & 0.1 \\ 0 & 0.2 \end{bmatrix}, A_2 = \begin{bmatrix} 0.2 & 0 \\ 0 & 0.1 \end{bmatrix}, B = \begin{bmatrix} 1 \\ 1 \end{bmatrix} \\ h_1 &= 0.1, \quad h_2 = 0.2 \end{aligned} \tag{32}$$

$$\Delta A_0 = \begin{bmatrix} 0.2 \sin(t) & 0 \\ 0 & 0.1 \sin(t) \end{bmatrix}, \Delta A_1 = \begin{bmatrix} 0.1 \cos(t) & 0 \\ 0 & 0.2 \cos(t) \end{bmatrix}, \Delta A_2 = \begin{bmatrix} 0.2 \cos(t) & 0 \\ 0 & 0.1 \cos(t) \end{bmatrix}.$$

Matching condition for external disturbances is given by:

$$D = B E = \begin{bmatrix} 1 \\ 1 \end{bmatrix} 0.2 \cos t; \quad f(t) = 0.2 \cos t$$

The LMI stability and sliding mode existence conditions are computed by MATLAB programming (see Appendix 2) where LMI Control Toolbox is used. The computational results are following:

$$\begin{aligned}
A0hat &= \begin{bmatrix} -0.3947 & -0.0911 \\ 0.9053 & 0.2089 \end{bmatrix}; A1hat = \begin{bmatrix} -0.0304 & -0.0304 \\ 0.0696 & 0.0696 \end{bmatrix}; A2hat = \begin{bmatrix} 0.0607 & -0.0304 \\ -0.1393 & 0.0696 \end{bmatrix} \\
Geq &= [0.6964 \quad 0.3036]; G = [-4.5759 \quad 12.7902] \\
A0til &= \begin{bmatrix} 4.1812 & -12.8812 \\ 5.4812 & -12.5812 \end{bmatrix}; eigA0til = \begin{bmatrix} -4.2000 + 0.6000i \\ -4.2000 - 0.6000i \end{bmatrix} \\
eigA0hat &= \begin{bmatrix} -0.1858 \\ 0.0000 \end{bmatrix}; eigA1hat = \begin{bmatrix} 0 \\ 0.0393 \end{bmatrix}; eigA2hat = \begin{bmatrix} 0.0000 \\ 0.1304 \end{bmatrix} \\
lhs &= \begin{bmatrix} -0.7085 & -0.5711 & -0.0085 & -0.0085 & 0.0169 & -0.0085 \\ -0.5711 & -0.8257 & 0.0084 & 0.0084 & -0.0167 & 0.0084 \\ -0.0085 & 0.0084 & -1.0414 & -0.2855 & 0 & 0 \\ -0.0085 & 0.0084 & -0.2855 & -1.1000 & 0 & 0 \\ 0.0169 & -0.0167 & 0 & 0 & -1.0414 & -0.2855 \\ -0.0085 & 0.0084 & 0 & 0 & -0.2855 & -1.1000 \end{bmatrix}; eigsLHS = \begin{bmatrix} -1.3581 \\ -1.3578 \\ -1.3412 \\ -0.7848 \\ -0.7837 \\ -0.1916 \end{bmatrix} \\
P &= \begin{bmatrix} 2.0633 & 0.7781 \\ 0.7781 & 0.4592 \end{bmatrix}; eigP = \begin{bmatrix} 0.1438 \\ 2.3787 \end{bmatrix}; R1 = \begin{bmatrix} 1.0414 & 0.2855 \\ 0.2855 & 1.1000 \end{bmatrix}; R2 = \begin{bmatrix} 1.0414 & 0.2855 \\ 0.2855 & 1.1000 \end{bmatrix} \\
eigR1 &= \begin{bmatrix} 0.7837 \\ 1.3578 \end{bmatrix}; eigR2 = \begin{bmatrix} 0.7837 \\ 1.3578 \end{bmatrix} \\
BTP &= [2.8414 \quad 1.2373]; BTPB = 4.0788 \\
invBTPB &= 0.2452; normG = 13.5841
\end{aligned}$$

$$\alpha_0 = 0.2; \alpha_1 = 0.2; \alpha_2 = 0.2; d = \max\|D\| = 0.2; f_0 = \max\|f(t)\| = 0.2828;$$

$$k_0 = 13.7841; k_1 = 0.2; k_2 = 0.2; \delta \geq 0.2828; H < 0;$$

Thus, we have designed all the parameters of the combined sliding mode controller.

Aircraft control design example 3: Consider the lateral-directional control design of the DC-8 aircraft in a cruise-flight configuration for $M = 0.84$, $h = 33.000\text{ft}$, and $V = 825\text{ft/s}$ with nominal parameters taken from (Schmidt, 1998):

$$\begin{bmatrix} \dot{r} \\ \dot{\beta} \\ \dot{p} \\ \dot{\phi} \end{bmatrix} = \begin{bmatrix} -0.228 & 2.148 & -0.021 & 0.0 \\ -1.0 & -0.0869 & 0.0 & 0.0390 \\ 0.335 & -4.424 & -1.184 & 0.0 \\ 0.0 & 0.0 & 1.0 & 0.0 \end{bmatrix} \begin{bmatrix} r \\ \beta \\ p \\ \phi \end{bmatrix} + \begin{bmatrix} -1.169 & 0.065 \\ 0.0223 & 0.0 \\ 0.0547 & 2.120 \\ 0.0 & 0.0 \end{bmatrix} \begin{bmatrix} \delta_r \\ \delta_a \end{bmatrix} \quad (33)$$

where β is the sideslip angle, deg., p is the roll rate, deg/s, ϕ is the bank angle, deg., r is the yaw rate, deg/s, δ_r is the rudder control, δ_a is the aileron control. However, some small transient time-delay effect in this equation may occur because of influence of sideslip on aerodynamics flow and flexibility effects of aerodynamic airframe and surfaces in lateral-directional couplings and directional-lateral couplings. The gain constants of gyro, rate gyro and actuators are included in to lateral directional equation of motion. Therefore, it is assumed that lateral direction motion of equation contains some delay effect and perturbed parameters as follows:

$$A_1 = \begin{bmatrix} 0 & 0 & -0.002 & 0.0 \\ 0 & 0 & 0.0 & 0.004 \\ 0.034 & -0.442 & 0 & 0 \\ 0.0 & 0.0 & 0 & 0 \end{bmatrix} \quad (34)$$

$$\Delta A_0 = 0.1A_0 \sin(t), \Delta A_1 = 0.1A_1 \cos(t), D = I_4; f = 0.2 \sin(t); h_1 = 0.01 - 0.04s$$

The LMI stability and sliding mode existence conditions are computed by MATLAB programming (see Appendix 3) where LMI Control Toolbox is used. The computational results are following:

$$A0hat = \begin{bmatrix} -0.0191 & -0.0008 & 0.0000 & 0.0007 \\ -1.0042 & -0.0434 & 0.0003 & 0.0390 \\ 0.0006 & 0.0000 & -0.0000 & -0.0000 \\ 0 & 0 & 1.0000 & 0 \end{bmatrix}; A1hat = \begin{bmatrix} -0.0000 & 0.0000 & -0.0000 & 0.0001 \\ -0.0000 & 0.0003 & -0.0000 & 0.0040 \\ 0.0000 & -0.0000 & 0.0000 & -0.0000 \\ 0 & 0 & 0 & 0 \end{bmatrix}$$

$$G = \begin{bmatrix} -0.8539 & 0.0163 & 0.0262 & 0 \\ 0.0220 & -0.0001 & 0.4710 & 0 \end{bmatrix}; G1 = \begin{bmatrix} -0.5925 & 0.0890 & 0.1207 & 0.0501 \\ 0.0689 & -0.0086 & 0.3452 & 0.0485 \end{bmatrix}$$

$$A0til = \begin{bmatrix} -0.7162 & 0.1038 & 0.1187 & 0.0561 \\ -0.9910 & -0.0454 & -0.0024 & 0.0379 \\ -0.1130 & 0.0134 & -0.7384 & -0.1056 \\ 0 & 0 & 1.0000 & 0 \end{bmatrix}$$

$$eigA0til = [-0.5+0.082i \ -0.5-0.082i \ -0.3 \ -0.2]$$

$$eigA0hat = [-0.0621 \ -0.0004 \ -0.0000 \ -0.0000]$$

$$eigA1hat = 1.0e-003 * \begin{bmatrix} 0.2577 \\ -0.0000 + 0.0000i \\ -0.0000 - 0.0000i \\ 0 \end{bmatrix}$$

$$P = \begin{bmatrix} 72.9293 & 39.4515 & -2.3218 & 24.7039 \\ 39.4515 & 392.5968 & 10.8368 & -1.4649 \\ -2.3218 & 10.8368 & 67.2609 & -56.4314 \\ 24.7039 & -1.4649 & -56.4314 & 390.7773 \end{bmatrix}; eigP = [57.3353 \ 66.3033 \ 397.7102 \ 402.2156]$$

$$R1 = \begin{bmatrix} 52.5926 & 29.5452 & 0.3864 & 2.5670 \\ 29.5452 & 62.3324 & 3.6228 & -0.4852 \\ 0.3864 & 3.6228 & 48.3292 & -32.7030 \\ 2.5670 & -0.4852 & -32.7030 & 61.2548 \end{bmatrix}; eigR1 = [21.3032 \ 27.3683 \ 86.9363 \ 88.9010]$$

$$BTP = \begin{bmatrix} -84.5015 & -36.7711 & 6.6350 & -31.9983 \\ -0.1819 & 25.5383 & 142.4423 & -118.0289 \end{bmatrix}$$

$$BTPB = \begin{bmatrix} 98.3252 & 8.5737 \\ 8.5737 & 301.9658 \end{bmatrix}; invBTPB = \begin{bmatrix} 0.0102 & -0.0003 \\ -0.0003 & 0.0033 \end{bmatrix}$$

$$\begin{aligned}
 \text{gnorm} = 0.8545 \text{lhs} = & \begin{bmatrix} -41.4566 & -29.8705 & -0.6169 & -2.3564 & -0.0008 & 0.0105 & -0.0016 & 0.1633 \\ -29.8705 & -51.6438 & -3.8939 & 0.8712 & -0.0078 & 0.1015 & -0.015 & 1.5728 \\ -0.6169 & -3.8939 & -38.2778 & 32.1696 & -0.0002 & 0.0028 & -0.0004 & 0.043 \\ -2.3564 & 0.8712 & 32.1696 & -51.6081 & 0 & -0.0002 & 0 & -0.0038 \\ -0.0008 & -0.0078 & -0.0002 & 0 & -52.593 & -29.545 & -0.3864 & -2.567 \\ 0.0105 & 0.1015 & 0.0028 & -0.0002 & -29.545 & -62.333 & -3.6228 & 0.4852 \\ -0.0016 & -0.015 & -0.0004 & 0 & -0.3864 & -3.6228 & -48.33 & 32.703 \\ 0.1633 & 1.5728 & 0.043 & -0.0038 & -2.567 & 0.4852 & 32.703 & -61.255 \end{bmatrix}; \\
 \text{eigsLHS} = & \begin{bmatrix} -88.9592 \\ -86.9820 \\ -78.9778 \\ -75.8961 \\ -27.3686 \\ -21.3494 \\ -16.0275 \\ -11.9344 \end{bmatrix}
 \end{aligned}$$

$$k_0 = 1.0545; \quad k_1 = 0.5; \quad \delta \geq 0.2; \quad H < 0;$$

Thus, we have designed all the parameters of the aircraft control system and the uncertain time-delay system (1), (4) with given nominal (33) and perturbed (34) parameters are simulated by using MATLAB-SIMULINK. The SIMULINK block diagram of the uncertain time-delay system with variable structure controller (VSC) is given in Fig. 1. Simulation results are given in Fig. 2, 3, 4 and 5. As seen from the last four figures, system time responses to the rudder and aileron pulse functions (0.3 within 3-6 sec) are stabilized very well for example the settling time is about 15-20 seconds while the state time responses of aircraft control action as shown in Fig. 5 are unstable or have poor dynamic characteristics. Notice that, as shown in Fig. 4, control action contains some switching, however it has no high chattering effects because the continuous terms of controller are dominant. Numerical examples and simulation results show the usefulness and effectiveness of the proposed design approach.

5. Robust delay-dependent stabilization

In this section, the existence condition of the sliding manifold and delay-dependent stability analysis of perturbed sliding time-delay systems are presented.

5.1 Robust delay-dependent stabilization on the sliding surface

In this section the sliding manifold is designed so that on it or in its neighborhood in different from existing methods the perturbed sliding time-delay system (16) is globally asymptotically stable with respect to state coordinates. The stability results are formulated in the following theorem.

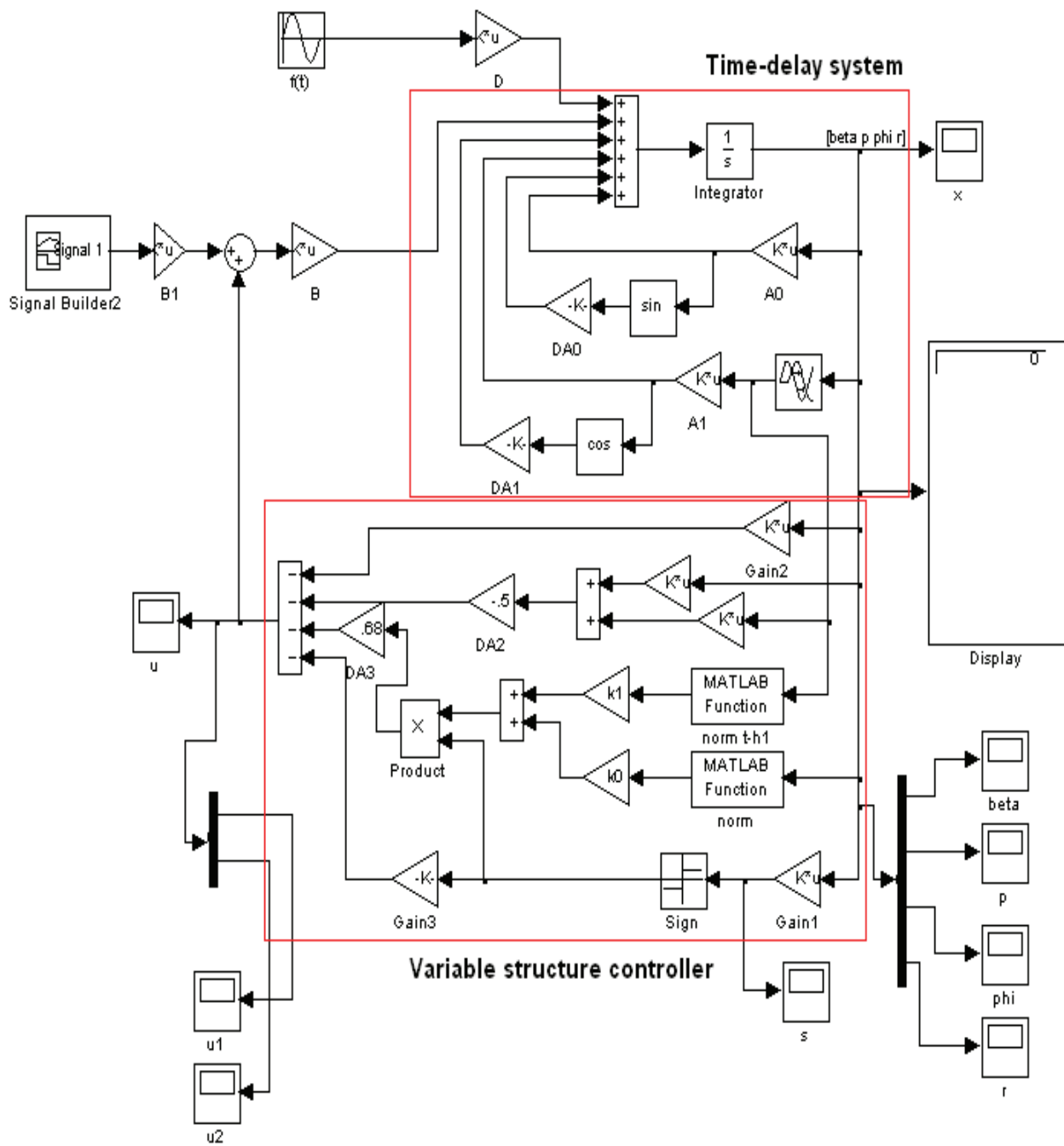

Fig. 1. SIMULINK block diagram of uncertain time-delay system with VSC

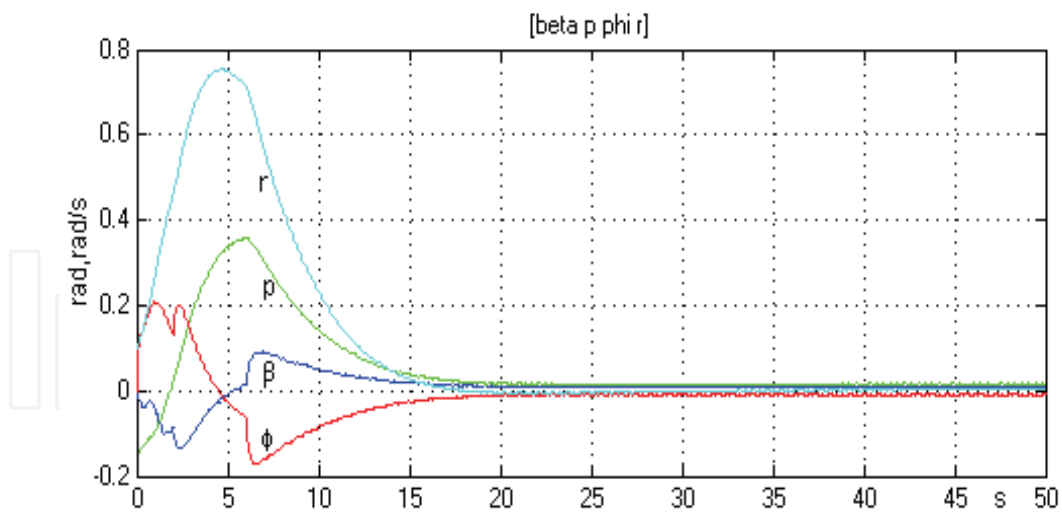

Fig. 2. States' time responses with control

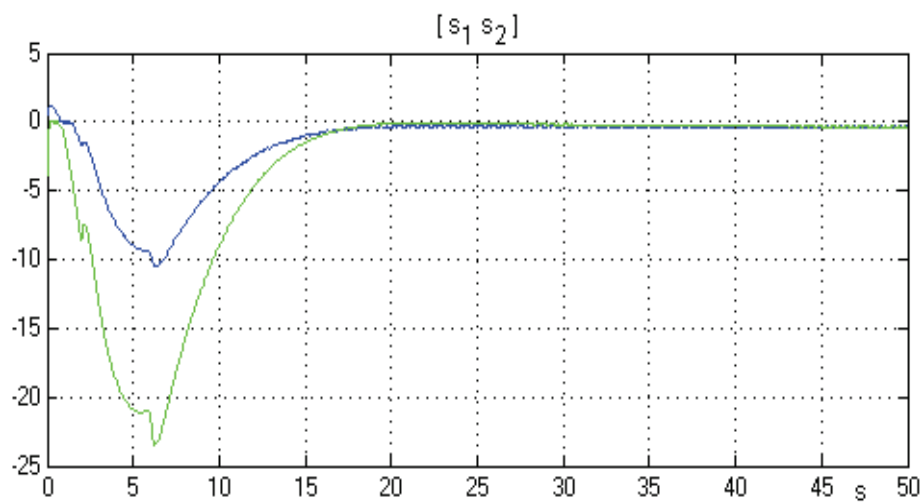

Fig. 3. Sliding functions

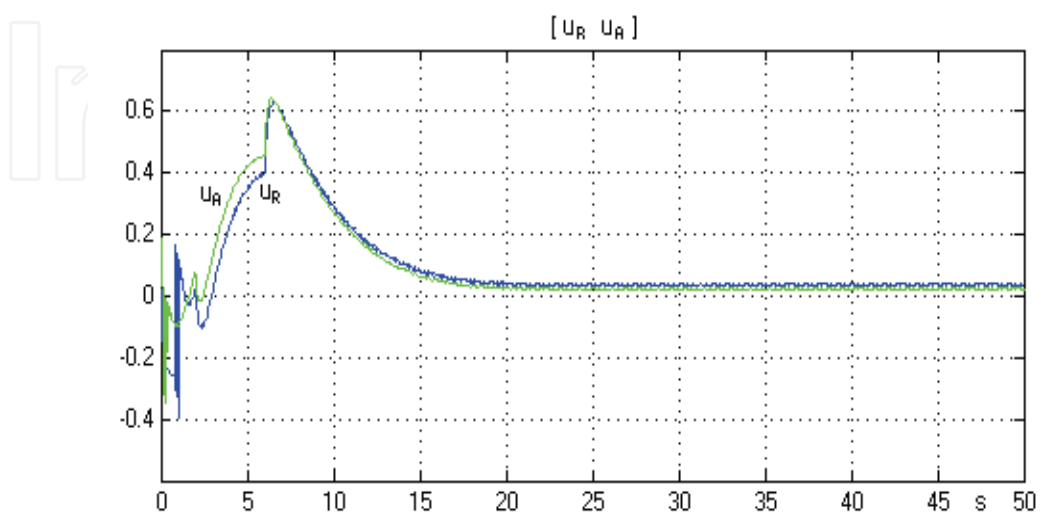

Fig. 4. Control functions

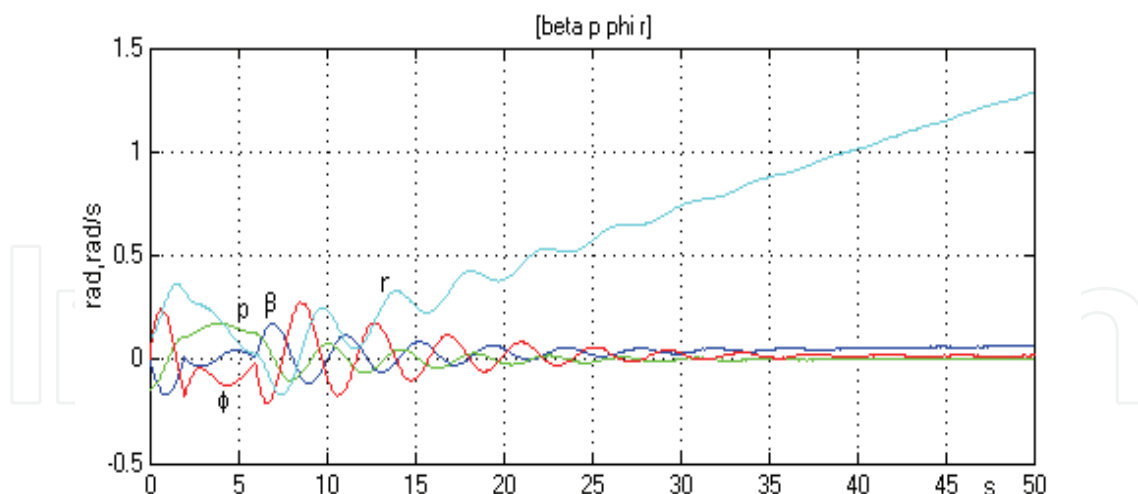

Fig. 5. States' time responses without control

Theorem 3: Suppose that Assumption 1 holds. Then the transformed multivariable sliding time-delay system (16) with matched parameter perturbations and external disturbances driven by combined controller (4) and restricted to the sliding surface $s(t)=0$ is robustly globally asymptotically delay-dependent stable with respect to the state variables, if the following modified LMI conditions and parameter requirements are satisfied:

$$H = \begin{bmatrix}
 H_{11} & -P\bar{A}_1\bar{A}_0 & -P\bar{A}_1^2 & \dots & -P\bar{A}_1\bar{A}_N & -P\bar{A}_N\bar{A}_0 & -P\bar{A}_N\bar{A}_1 & \dots & -P\bar{A}_N^2 & 0 & 0 & 0 & 0 \\
 * & -\frac{1}{h_1}R_1 & 0 & & 0 & 0 & 0 & & 0 & & & & 0 \\
 * & 0 & -\frac{1}{h_1}S_1 & & 0 & & & & & & & & 0 \\
 \vdots & & & \ddots & 0 & & & & & & & & 0 \\
 * & 0 & 0 & 0 & -\frac{1}{h_N}R_N & & & & & & & & 0 \\
 * & 0 & 0 & 0 & 0 & & & & & & & & 0 \\
 \vdots & & & & & & & & & & & & 0 \\
 0 & & & & & & & & -\frac{1}{h_1}S_N & 0 & 0 & 0 & 0 \\
 0 & & & & & & & & 0 & 0 & -T_1 & 0 & 0 \\
 0 & & & & & & & & 0 & 0 & 0 & \ddots & 0 \\
 0 & 0 & 0 & 0 & 0 & 0 & 0 & & 0 & 0 & 0 & 0 & -T_N
 \end{bmatrix} < 0 \quad (35)$$

where

$$H_{11} = (\tilde{A}_0 + \bar{A}_1 + \dots + \bar{A}_N)^T P + P(\tilde{A}_0 + \bar{A}_1 + \dots + \bar{A}_N) + h_1(S_1 + R_1) + \dots + h_N(S_N + R_N) + T_1 + \dots + T_N$$

$$CB = B^T P B > 0 \quad (36)$$

$$k_0 = \alpha_0; k_1 = \alpha_1; \dots; k_N = \alpha_N; \quad (37)$$

$$\delta \geq f_0 \quad (38)$$

where P, R_1, \dots, R_N are some symmetric positive definite matrices which are a feasible solution of modified LMI (35) with (36); $\tilde{A}_0 = A_0 - BG$ is a stable matrix.

Proof: Let us choose a special augmented Lyapunov-Krasovskii functional as follows:

$$V = x^T(t)Px(t) + \sum_{i=1}^N \int_{-h_i}^0 \int_{t+\theta}^t x^T(\rho)R_i x(\rho)d\rho d\theta + \sum_{i=1}^N \int_{-h_i}^0 \int_{t+\theta-h_i}^t x^T(\rho)S_i x(\rho)d\rho d\theta + \sum_{i=1}^N \int_{t-h_i}^t x^T(\theta)T_i x(\theta)d\theta \quad (39)$$

The introduced special augmented functional (39) involves three particular terms: first term V_1 is standard Lyapunov function, second and third are non-standard terms, namely V_2 and V_3 are similar, except for the length integration horizon $[t-h, t]$ for V_2 and $[t+\theta-h, t]$ for V_3 , respectively. This functional is different from existing ones.

The time-derivative of (39) along the perturbed time-delay system (16) can be calculated as:

$$\begin{aligned} \dot{V} = & x^T(t) \left[(\tilde{A}_0 + \bar{A}_1 + \dots + \bar{A}_N)^T P + P(\tilde{A}_0 + \bar{A}_1 + \dots + \bar{A}_N) \right. \\ & \left. + h_1(S_1 + R_1) + \dots + h_N(S_N + R_N) + T_1 + \dots + T_N x(t) \right] \\ & - 2x^T(t)P\bar{A}_1\bar{A}_0 \int_{t-h_1}^t x(\theta)d\theta - 2x^T(t)P\bar{A}_1^2 \int_{t-h_1}^t x(\theta-h_1)d\theta - \dots - 2x^T(t)P\bar{A}_1\bar{A}_N \int_{t-h_1}^t x(\theta-h_N)d\theta \\ & - \dots - 2x^T(t)P\bar{A}_N\bar{A}_0 \int_{t-h_N}^t x(\theta)d\theta - 2x^T(t)P\bar{A}_N\bar{A}_1 \int_{t-h_N}^t x(\theta-h_1)d\theta - \dots - 2x^T(t)P\bar{A}_N^2 \int_{t-h_N}^t x(\theta-h_N)d\theta \\ & - h_1 \int_{t-h_1}^t x^T(\theta)R_1 x(\theta)d\theta - \dots - h_N \int_{t-h_N}^t x^T(\theta)R_N x(\theta)d\theta \\ & - h_1 \int_{t-h_1}^t x^T(\theta-h_1)S_1 x(\theta-h_1)d\theta - \dots - h_N \int_{t-h_N}^t x^T(\theta-h_N)S_N x(\theta-h_N)d\theta \\ & - x^T(t-h_1)T_1 x(t-h_1) - x^T(t-h_N)T_N x(t-h_N) \\ & + 2x^T(t)P\Delta A_1 x(t-h_1) + \dots + 2x^T(t)P\Delta A_N x(t-h_N) - 2x^T(t)PB[k_0 \|x(t)\| + k_1 \|x(t-h_1)\| \\ & + \dots + k_N \|x(t-h_N)\|] \frac{s(t)}{\|s(t)\|} - 2x^T(t)PB\delta \frac{s(t)}{\|s(t)\|} + x^T(t)PDf(t) \end{aligned} \quad (40)$$

Since for some $h > 0$ Noldus inequality holds:

$$\begin{aligned} h_1 \int_{t-h_1}^t x^T(\theta)R_1 x(\theta)d\theta & \geq \left[\int_{t-h_1}^t x(\theta)d\theta \right]^T R_1 \left[\int_{t-h_1}^t x(\theta)d\theta \right] \dots \\ h_N \int_{t-h_N}^t x^T(\theta-h_N)S_N x(\theta-h_N)d\theta & \geq \left[\int_{t-h_N}^t x(\theta-h_N)d\theta \right]^T S_N \left[\int_{t-h_N}^t x(\theta-h_N)d\theta \right] \end{aligned} \quad (41)$$

and $x^T(t)PB = s^T(t)$ then (40) becomes as:

$$\begin{aligned}
 \dot{V} &\leq x^T(t) \left[(\tilde{A}_0 + \bar{A}_1 + \dots + \bar{A}_N)^T P + P(\tilde{A}_0 + \bar{A}_1 + \dots + \bar{A}_N) + h_1(S_1 + R_1) + \dots + h_N(S_N + R_N) + T_1 + \dots + T_N \right] x(t) \\
 &\quad - 2x^T(t)P\bar{A}_1\bar{A}_0 \int_{t-h_1}^t x(\theta)d\theta - 2x^T(t)P\bar{A}_1^2 \int_{t-h_1}^t x(\theta-h_1)d\theta \\
 &\quad - \dots - 2x^T(t)P\bar{A}_1\bar{A}_N \int_{t-h_1}^t x(\theta-h_N)d\theta - \dots - 2x^T(t)P\bar{A}_N\bar{A}_0 \int_{t-h_N}^t x(\theta)d\theta \\
 &\quad - 2x^T(t)P\bar{A}_N\bar{A}_1 \int_{t-h_N}^t x(\theta-h_1)d\theta - \dots - 2x^T(t)P\bar{A}_N^2 \int_{t-h_N}^t x(\theta-h_N)d\theta - \frac{1}{h_1} \left[\int_{t-h_1}^t x(\theta)d\theta \right]^T R_1 \left[\int_{t-h_1}^t x(\theta)d\theta \right] \\
 &\quad - \dots - \frac{1}{h_N} \left[\int_{t-h_N}^t x(\theta)d\theta \right]^T R_N \left[\int_{t-h_N}^t x(\theta)d\theta \right] - \frac{1}{h_1} \left[\int_{t-h_1}^t x(\theta-h_1)d\theta \right]^T S_1 \left[\int_{t-h_1}^t x(\theta-h_1)d\theta \right] \\
 &\quad - \dots - \frac{1}{h_N} \left[\int_{t-h_N}^t x(\theta-h_N)d\theta \right]^T S_N \left[\int_{t-h_N}^t x(\theta-h_N)d\theta \right] - x^T(t-h_1)T_1x(t-h_1) - x^T(t-h_N)T_Nx(t-h_N) \\
 &\quad + 2x^T(t)PBE_1x(t-h_1) + \dots + 2x^T(t)PBE_Nx(t-h_N) - 2x^T(t)PB \left[k_0\|x(t)\| + k_1\|x(t-h_1)\| \right. \\
 &\quad \left. + \dots + k_N\|x(t-h_N)\| \right] \frac{s(t)}{\|s(t)\|} - 2x^T(t)PB\delta \frac{s(t)}{\|s(t)\|} + x^T(t)PBEf(t) \\
 &\leq x^T(t) \left[(\tilde{A}_0 + \bar{A}_1 + \dots + \bar{A}_N)^T P + P(\tilde{A}_0 + \bar{A}_1 + \dots + \bar{A}_N) + h_1(S_1 + R_1) + \dots + h_N(S_N + R_N) + T_1 + \dots + T_N \right] x(t) \\
 &\quad - 2x^T(t)P\bar{A}_1\bar{A}_0 \int_{t-h_1}^t x(\theta)d\theta - 2x^T(t)P\bar{A}_1^2 \int_{t-h_1}^t x(\theta-h_1)d\theta - \dots - 2x^T(t)P\bar{A}_1\bar{A}_N \int_{t-h_1}^t x(\theta-h_N)d\theta \\
 &\quad - \dots - 2x^T(t)P\bar{A}_N\bar{A}_0 \int_{t-h_N}^t x(\theta)d\theta - 2x^T(t)P\bar{A}_N\bar{A}_1 \int_{t-h_N}^t x(\theta-h_1)d\theta - \dots - 2x^T(t)P\bar{A}_N^2 \int_{t-h_N}^t x(\theta-h_N)d\theta \\
 &\quad - \frac{1}{h_1} \left[\int_{t-h_1}^t x(\theta)d\theta \right]^T R_1 \left[\int_{t-h_1}^t x(\theta)d\theta \right] - \dots - \frac{1}{h_N} \left[\int_{t-h_N}^t x(\theta)d\theta \right]^T R_N \left[\int_{t-h_N}^t x(\theta)d\theta \right] \\
 &\quad - \frac{1}{h_1} \left[\int_{t-h_1}^t x(\theta-h_1)d\theta \right]^T S_1 \left[\int_{t-h_1}^t x(\theta-h_1)d\theta \right] - \dots - \frac{1}{h_N} \left[\int_{t-h_N}^t x(\theta-h_N)d\theta \right]^T S_N \left[\int_{t-h_N}^t x(\theta-h_N)d\theta \right] \\
 &\quad - x^T(t-h_1)T_1x(t-h_1) - x^T(t-h_N)T_Nx(t-h_N) + 2s^T(t)E_1x(t-h_1) + \dots + 2s^T(t)E_Nx(t-h_N) \\
 &\quad - 2s^T(t) \left[k_0\|x(t)\| + k_1\|x(t-h_1)\| + \dots + k_N\|x(t-h_N)\| \right] \frac{s(t)}{\|s(t)\|} - 2\delta s^T(t) \frac{s(t)}{\|s(t)\|} + s^T(t)Ef(t) \\
 &= \left[x(t) \int_{t-h_1}^t x(\theta)d\theta \int_{t-h_1}^t x(\theta-h_1)d\theta \int_{t-h_1}^t x(\theta-h_N)d\theta \int_{t-h_N}^t x(\theta)d\theta \int_{t-h_N}^t x(\theta-h_1)d\theta \int_{t-h_N}^t x(\theta-h_N)d\theta \quad x(t-h_1) \quad x(t-h_N) \right]
 \end{aligned}$$

$$\begin{bmatrix}
 H_{11} & -P\bar{A}_1\bar{A}_0 & -P\bar{A}_1^2 & \dots & -P\bar{A}_1\bar{A}_N & -P\bar{A}_N\bar{A}_0 & -P\bar{A}_N\bar{A}_1 & \dots & -P\bar{A}_N^2 & 0 & 0 & 0 & 0 \\
 * & -\frac{1}{h_1}R_1 & 0 & & 0 & 0 & 0 & & 0 & 0 & 0 & 0 & 0 \\
 * & 0 & -\frac{1}{h_1}S_1 & & 0 & & 0 & & 0 & & & & 0 \\
 \vdots & 0 & 0 & \ddots & 0 & & 0 & & 0 & & & & 0 \\
 * & 0 & 0 & & -\frac{1}{h_N}R_N & & 0 & & 0 & & & & 0 \\
 * & 0 & 0 & & 0 & & 0 & & 0 & & & & 0 \\
 * & 0 & 0 & & 0 & & 0 & & 0 & & & & 0 \\
 \vdots & & & & & & \ddots & & 0 & & & & 0 \\
 * & 0 & 0 & & & & -\frac{1}{h_1}S_N & & 0 & 0 & 0 & 0 & 0 \\
 0 & 0 & 0 & & & & 0 & & 0 & -T_1 & 0 & 0 & 0 \\
 0 & 0 & 0 & & & & 0 & & 0 & 0 & 0 & \ddots & 0 \\
 0 & 0 & 0 & & 0 & 0 & 0 & 0 & 0 & 0 & 0 & 0 & -T_N
 \end{bmatrix}
 \begin{bmatrix}
 x(t) \\
 \int_{t-h_1}^t x(\theta)d\theta \\
 \int_{t-h_1}^t x(\theta-h_1)d\theta \\
 \vdots \\
 \int_{t-h_1}^t x(\theta-h_N)d\theta \\
 \int_{t-h_N}^t x(\theta)d\theta \\
 \int_{t-h_N}^t x(\theta-h_1)d\theta \\
 \vdots \\
 \int_{t-h_N}^t x(\theta-h_N)d\theta \\
 x(t-h_1) \\
 \vdots \\
 x(t-h_N)
 \end{bmatrix}$$

$$-[(k_0 - \alpha_0)\|x(t)\|\|s(t)\| + (k_1 - \alpha_1)\|x(t-h_1)\|\|s(t)\| + \dots + (k_N - \alpha_N)\|x(t-h_N)\|\|s(t)\|] - (\delta - f_0)\|s(t)\| \quad (42)$$

Since (35)-(38) hold, then (42) reduces to:

$$\dot{V} \leq z^T(t)Hz(t) < 0 \quad (43)$$

Therefore, we can conclude that the perturbed time-delay system (16), (4) is robustly globally asymptotically delay-dependent stable. Theorem 3 is proved.

Special case: Single state-delayed systems: For single state-delayed systems that are frequently encountered in control applications and testing examples equation of motion and control algorithm can be easily found from (1), (4), (16) letting N=1. Therefore, the modified LMI delay-dependent stability conditions for which are significantly reduced and can be summarized in the following Corollary.

Corollary 1: Suppose that Assumption 1 holds. Then the transformed single-delayed sliding system (16) with matched parameter perturbations and external disturbances driven by combined controller (4) for which N=1 and restricted by sliding surface s(t)=0 is robustly globally asymptotically delay-dependent stable with respect to the state variables, if the following LMI conditions and parameter requirements are satisfied:

$$H = \begin{bmatrix}
 (\tilde{A}_0 + \bar{A}_1)^T P + P(\tilde{A}_0 + \bar{A}_1) & -P\bar{A}_1\bar{A}_0 & -P\bar{A}_1^2 & 0 \\
 +h_1(S_1 + R_1) + T_1 & & & \\
 -(P\bar{A}_1\bar{A}_0)^T & -\frac{1}{h_1}R_1 & 0 & 0 \\
 -(P\bar{A}_1^2)^T & 0 & -\frac{1}{h_1}S_1 & 0 \\
 0 & 0 & 0 & -T_1
 \end{bmatrix} < 0 \quad (44)$$

$$CB = B^T PB > 0 \tag{45}$$

$$k_0 = \alpha_0; k_1 = \alpha_1; \tag{46}$$

$$\delta \geq f_0 \tag{47}$$

Proof: The corollary follows from the proof of the Theorem 3 letting $N=1$.

5.2 Existence conditions

The final step of the control design is the derivation of the sliding mode existence conditions or the reaching conditions for the perturbed time-delay system states to the sliding manifold in finite time. These results are summarized in the following theorem.

Theorem 4: Suppose that Assumption 1 holds. Then the perturbed multivariable time-delay system (1) states with matched parameter uncertainties and external disturbances driven by controller (4) converge to the sliding surface $s(t)=0$ in finite time, if the following conditions are satisfied:

$$k_0 = \alpha_0 + g; k_1 = \alpha_1; \dots, k_N = \alpha_N; \tag{48}$$

$$\delta \geq f_0 \tag{49}$$

Proof: Let us choose a modified Lyapunov function candidate as:

$$V = \frac{1}{2} s^T(t) (CB)^{-1} s(t) \tag{50}$$

The time-derivative of (50) along the state trajectories of time-delay system (1), (4) can be calculated as follows:

$$\begin{aligned} \dot{V} &= s^T(t) (CB)^{-1} \dot{s}(t) = s^T(t) (CB)^{-1} C \dot{x}(t) = s^T(t) (CB)^{-1} C [A_0 x(t) + A_1 x(t-h_1) \\ &\quad + \dots + A_N x(t-h_N) + \Delta A_0 x(t) + \Delta A_1 x(t-h_1) + \dots + \Delta A_N x(t-h_N) + Bu(t) + Df(t)] \\ &= s^T(t) (CB)^{-1} [CA_0 x(t) + CA_1 x(t-h_1) + \dots + CA_N x(t-h_N) + CBE_0 x(t) + CBE_1 x(t-h_1) \\ &\quad + \dots + CBE_N x(t-h_N) - CB((CB)^{-1} [CA_0 x(t) + CA_1 x(t-h) + \dots + CA_N x(t-h_N)] \\ &\quad - [k_0 \|x(t)\| + k_1 \|x(t-h_1)\| + \dots + k_N \|x(t-h_N)\|]) \frac{s(t)}{\|s(t)\|} - Gx(t) - \delta \frac{s(t)}{\|s(t)\|} + CBEf(t)] \tag{51} \\ &= s^T(t) [E_0 x(t) + E_1 x(t-h_1) + \dots + E_N x(t-h_N) \\ &\quad - [k_0 \|x(t)\| + k_1 \|x(t-h_1)\| + \dots + k_N \|x(t-h_N)\|] \frac{s(t)}{\|s(t)\|} - Gx(t) - \delta \frac{s(t)}{\|s(t)\|} + Ef(t)] \\ &\leq -[(k_0 - \alpha_0 - g) \|x(t)\| \|s(t)\| + (k_1 - \alpha_1) \|x(t-h_1)\| \|s(t)\| \\ &\quad + \dots + (k_N - \alpha_N) \|x(t-h_N)\| \|s(t)\|] - (\delta - f_0) \|s(t)\| \end{aligned}$$

Since (48), (49) hold, then (51) reduces to:

$$\dot{V} = s^T(t) (CB)^{-1} \dot{s}(t) \leq -(\delta - f_0) \|s(t)\| \leq -\eta \|s(t)\| \tag{52}$$

where

$$\eta = \delta - f_0 \geq 0 \quad (53)$$

Hence we can evaluate that

$$\dot{V}(t) \leq -\eta \sqrt{\frac{2}{\lambda_{\min}(CB)^{-1}}} \sqrt{V(t)} \quad (54)$$

The last inequality (54) is known to prove the finite-time convergence of system (1),(4) towards the sliding surface $s(t)=0$ (Utkin, 1977), (Perruquetti & Barbot, 2002). Therefore, Theorem 4 is proved.

5.3. Numerical examples

In order to demonstrate the usefulness of the proposed control design techniques let us consider the following examples.

Example 4: Consider a time-delay system (1),(4) with parameters taken from (Li & De Carlo, 2003):

$$A_0 = \begin{bmatrix} 2 & 0 & 1 \\ 1.75 & 0.25 & 0.8 \\ -1 & 0 & 1 \end{bmatrix}; A_1 = \begin{bmatrix} -1 & 0 & 0 \\ -0.1 & 0.25 & 0.2 \\ -0.2 & 4 & 5 \end{bmatrix}; B = \begin{bmatrix} 0 \\ 0 \\ 1 \end{bmatrix};$$

$$\Delta A_0 = 0.2 \sin(t) A_0, \Delta A_1 = 0.2 \cos(t) A_1, f = 0.3 \sin(t)$$

The LMI delay-dependent stability and sliding mode existence conditions are computed by MATLAB programming (see Appendix 4) where LMI Control Toolbox is used. The computational results are following:

$$G_{eq} = \begin{bmatrix} 1.2573 & 2.5652 & 1.0000 \end{bmatrix}$$

$$A0hat = \begin{bmatrix} 2.0000 & 0 & 1.0000 \\ 1.7500 & 0.2500 & 0.8000 \\ -7.0038 & -0.6413 & -3.3095 \end{bmatrix}; A1hat = \begin{bmatrix} -1.0000 & 0 & 0 \\ -0.1000 & 0.2500 & 0.2000 \\ 1.5139 & -0.6413 & -0.5130 \end{bmatrix}$$

$$eigA0hat = \begin{bmatrix} -0.5298 + 0.5383i \\ -0.5298 - 0.5383i \\ 0.0000 \end{bmatrix}; eigA1hat = \begin{bmatrix} -0.2630 & -0.0000 & -1.0000 \end{bmatrix}$$

$$G = \begin{bmatrix} 3.3240 & 10.7583 & 3.2405 \end{bmatrix}; G_{eq} = \begin{bmatrix} 1.2573 & 2.5652 & 1.0000 \end{bmatrix}$$

$$A0til = \begin{bmatrix} 2.0000 & 0 & 1.0000 \\ 1.7500 & 0.2500 & 0.8000 \\ -10.3278 & -11.3996 & -6.5500 \end{bmatrix}; eigA0til = \begin{bmatrix} -2.7000 \\ -0.8000 + 0.5000i \\ -0.8000 - 0.5000i \end{bmatrix}$$

$$P = 1.0e+008 * \begin{bmatrix} 1.1943 & -1.1651 & 0.1562 \\ -1.1651 & 4.1745 & 0.3597 \\ 0.1562 & 0.3597 & 0.1248 \end{bmatrix}; R1 = 1.0e+008 * \begin{bmatrix} 1.9320 & 0.2397 & 0.8740 \\ 0.2397 & 1.0386 & 0.2831 \\ 0.8740 & 0.2831 & 0.4341 \end{bmatrix}$$

$$S1 = 1.0e+008 * \begin{bmatrix} 0.8783 & 0.1869 & 0.2951 \\ 0.1869 & 1.0708 & 0.2699 \\ 0.2951 & 0.2699 & 0.1587 \end{bmatrix}; T1 = 1.0e+007 * \begin{bmatrix} 2.3624 & -0.7303 & 0.7264 \\ -0.7303 & 7.5758 & 1.1589 \\ 0.7264 & 1.1589 & 0.4838 \end{bmatrix}$$

lhs = 1.0e+008 *

$$\begin{bmatrix} -1.1632 & 0.4424 & -0.1828 & 0.1743 & -0.1030 & 0.1181 & -0.4064 & -0.1030 & -0.0824 & 0 & 0 & 0 \\ 0.4424 & -1.6209 & -0.1855 & 0.5480 & 0.2138 & 0.2098 & 0.3889 & 0.2138 & 0.1711 & 0 & 0 & 0 \\ -0.1828 & -0.1855 & -0.0903 & 0.0445 & 0.0026 & 0.0215 & -0.0142 & 0.0026 & 0.0021 & 0 & 0 & 0 \\ 0.1743 & 0.5480 & 0.0445 & -1.9320 & -0.2397 & -0.8740 & 0 & 0 & 0 & 0 & 0 & 0 \\ -0.1030 & 0.2138 & 0.0026 & -0.2397 & -1.0386 & -0.2831 & 0 & 0 & 0 & 0 & 0 & 0 \\ 0.1181 & 0.2098 & 0.0215 & -0.8740 & -0.2831 & -0.4341 & 0 & 0 & 0 & 0 & 0 & 0 \\ -0.4064 & 0.3889 & -0.0142 & 0 & 0 & 0 & -0.8783 & -0.1869 & -0.2951 & 0 & 0 & 0 \\ -0.1030 & 0.2138 & 0.0026 & 0 & 0 & 0 & -0.1869 & -1.0708 & -0.2699 & 0 & 0 & 0 \\ -0.0824 & 0.1711 & 0.0021 & 0 & 0 & 0 & -0.2951 & -0.2699 & -0.1587 & 0 & 0 & 0 \\ 0 & 0 & 0 & 0 & 0 & 0 & 0 & 0 & 0 & -0.2362 & 0.0730 & -0.0726 \\ 0 & 0 & 0 & 0 & 0 & 0 & 0 & 0 & 0 & 0.0730 & -0.7576 & -0.1159 \\ 0 & 0 & 0 & 0 & 0 & 0 & 0 & 0 & 0 & -0.0726 & -0.1159 & -0.0484 \end{bmatrix}$$

$$\text{maxh1} = 1; \text{eigsLHS} = 1.0e+008 * \begin{bmatrix} -2.8124 \\ -2.0728 \\ -1.0975 \\ -0.9561 \\ -0.8271 \\ -0.7829 \\ -0.5962 \\ -0.2593 \\ -0.0216 \\ -0.0034 \\ -0.0000 \\ -0.0000 \end{bmatrix}; \text{NormP} = 4.5946e+008$$

$$G = [3.3240 \quad 10.7583 \quad 3.2405]; \text{NormG} = 11.7171$$

$$\text{invBtPB} = 8.0109e-008; \text{BtP} = 1.0e+007 * [1.5622 \quad 3.5970 \quad 1.2483]$$

$$\text{eigP} = 1.0e+008 * \begin{bmatrix} 0.0162 \\ 0.8828 \\ 4.5946 \end{bmatrix}; \text{eigR1} = 1.0e+008 * \begin{bmatrix} 0.0070 \\ 0.9811 \\ 2.4167 \end{bmatrix}$$

$$\text{eigS1} = 1.0e+008 * \begin{bmatrix} 0.0159 \\ 0.7770 \\ 1.3149 \end{bmatrix}; \text{eigT1} = 1.0e+007 * \begin{bmatrix} 0.0000 \\ 2.5930 \\ 7.8290 \end{bmatrix}$$

$$k_0 = 11.9171; k_1 = 0.2; \delta \geq 0.3; H < 0$$

Considered time-delay system is delay-dependently robustly asymptotically stable for all constant delays $h \leq 1$.

Example 5: Now, let us consider a networked control time-delay system (1), (4) with parameters taken from (Cao et al., 2007):

$$A_0 = \begin{bmatrix} -4 & 0 \\ -1 & -3 \end{bmatrix}, A_1 = \begin{bmatrix} -1.5 & 0 \\ -1 & -0.5 \end{bmatrix}, B = \begin{bmatrix} 2 \\ 2 \end{bmatrix};$$

$$\Delta A_0 = 0.5 \sin(t) A_0, \Delta A_1 = 0.5 \cos(t) A_1, f = 0.3 \sin(t)$$

The LMI delay-dependent stability and sliding mode existence conditions are computed by MATLAB programming (see Appendix 5) where LMI Control Toolbox is used. The computational results are following:

$$\max h_1 = 2.0000; G_{eq} = \begin{bmatrix} 0.4762 & 0.0238 \end{bmatrix}$$

$$A_0 \text{hat} = \begin{bmatrix} -0.1429 & 0.1429 \\ 2.8571 & -2.8571 \end{bmatrix}; A_1 \text{hat} = \begin{bmatrix} -0.0238 & 0.0238 \\ 0.4762 & -0.4762 \end{bmatrix}$$

$$\text{eig} A_0 \text{hat} = \begin{bmatrix} -0.0000 \\ -3.0000 \end{bmatrix}; \text{eig} A_1 \text{hat} = \begin{bmatrix} -0.0000 \\ -0.5000 \end{bmatrix}$$

$$A_0 \text{til} = \begin{bmatrix} -4.1429 & -0.0571 \\ -1.1429 & -3.0571 \end{bmatrix}; \text{eig} A_0 \text{til} = \begin{bmatrix} -4.2000 \\ -3.0000 \end{bmatrix}$$

$$P = 1.0e+004 * \begin{bmatrix} 5.7534 & -0.1805 \\ -0.1805 & 0.4592 \end{bmatrix}; R_1 = 1.0e+004 * \begin{bmatrix} 8.4457 & -0.2800 \\ -0.2800 & 0.6883 \end{bmatrix}$$

$$S_1 = 1.0e+004 * \begin{bmatrix} 7.7987 & 0.2729 \\ 0.2729 & 0.1307 \end{bmatrix}; T_1 = 1.0e+004 * \begin{bmatrix} 6.7803 & 0.3390 \\ 0.3390 & 0.0170 \end{bmatrix}$$

$$\text{lhs} = 1.0e+004 *$$

$$\begin{bmatrix} -8.4351 & 1.2170 & -0.6689 & 0.6689 & -0.1115 & 0.1115 & 0 & 0 \\ 1.2170 & -1.5779 & 0.6689 & -0.6689 & 0.1115 & -0.1115 & 0 & 0 \\ -0.6689 & 0.6689 & -4.2228 & 0.1400 & 0 & 0 & 0 & 0 \\ 0.6689 & -0.6689 & 0.1400 & -0.3442 & 0 & 0 & 0 & 0 \\ -0.1115 & 0.1115 & 0 & 0 & -3.8994 & -0.1364 & 0 & 0 \\ 0.1115 & -0.1115 & 0 & 0 & -0.1364 & -0.0653 & 0 & 0 \\ 0 & 0 & 0 & 0 & 0 & 0 & -6.7803 & -0.3390 \\ 0 & 0 & 0 & 0 & 0 & 0 & -0.3390 & -0.0170 \end{bmatrix}$$

$$\text{eigsLHS} = 1.0\text{e}+004 * \begin{bmatrix} -8.8561 \\ -6.7973 \\ -4.1971 \\ -3.9040 \\ -1.4904 \\ -0.0971 \\ -0.0000 \\ -0.0000 \end{bmatrix}; \quad \text{NormP} = 5.7595\text{e}+004; \quad \text{G} = \begin{bmatrix} 2.0000 & 0.1000 \end{bmatrix}$$

$$\text{NormG} = 2.0025; \quad \text{invBtPB} = 4.2724\text{e}-006; \quad \text{BtP} = 1.0\text{e}+005 * \begin{bmatrix} 1.1146 & 0.0557 \end{bmatrix}$$

$$\text{eigsP} = 1.0\text{e}+004 * \begin{bmatrix} 0.4530 \\ 5.7595 \end{bmatrix}; \quad \text{eigsR1} = 1.0\text{e}+004 * \begin{bmatrix} 0.6782 \\ 8.4558 \end{bmatrix}$$

$$\text{eigsS1} = 1.0\text{e}+004 * \begin{bmatrix} 0.1210 \\ 7.8084 \end{bmatrix}; \quad \text{eigsT1} = 1.0\text{e}+004 * \begin{bmatrix} 0.0000 \\ 6.7973 \end{bmatrix}$$

$$k_0 = 2.5025; \quad k_1 = 0.5; \quad \delta \geq 0.3; \quad H < 0$$

The networked control time-delay system is robustly asymptotically delay-dependent stable for all constant time-delays $h \leq 2.0000$.

Thus, we have designed all the parameters of the combined sliding mode controller.

Numerical examples show the usefulness of the proposed design approach.

6. Conclusion

The problem of the sliding mode control design for matched uncertain multi-input systems with several fixed state delays by using of LMI approach has been considered. A new combined sliding mode controller has been proposed and designed for the stabilization of uncertain time-delay systems with matched parameter perturbations and external disturbances. Delay-independent and delay-dependent global stability and sliding mode existence conditions have been derived by using Lyapunov-Krasovskii functional method and formulated in terms of linear matrix inequality techniques. The allowable upper bounds on the time-delay are determined from the LMI stability conditions. These bounds are independent in different from existing ones of the parameter uncertainties and external disturbances.

Five numerical examples and simulation results with aircraft control application have illustrated the usefulness of the proposed design approach.

The obtained results of this work are presented in (Jafarov, 2008), (Jafarov, 2009).

7. Appendices

A1

clear;

clc;

```

A0=[-4 0; -1 -3];
A1=[-1.5 0; -1 -0.5];
B =[ 2; 2];
setlmis([])
P =lmivar(1,[2 1]);
R1=lmivar(1,[2 1]);
Geq=inv(B'*P*B)*B'*P
A0hat=A0-B*G*A0
A1hat=A1-B*G*A1
G= place(A0hat,B,[-4.5 -3])
A0til=A0hat-B*G1
eigA0til=eig(A0til)
eigA0hat=eig(A0hat)
eigA1hat=eig(A1hat)
ii = 1;
lmiterm([-1 1 1 P],ii,ii)
lmiterm([-2 1 1 R1],ii,ii)
lmiterm([4 1 1 P],1,A0til,'s')
lmiterm([4 1 1 R1],ii,ii)
lmiterm([4 2 2 R1],-ii,ii)
lmiterm([4 1 2 P],1,A1hat)
LMISYS=getlmis;
[copt,xopt]=feasp(LMISYS);
P=dec2mat(LMISYS,xopt,P);
R1=dec2mat(LMISYS,xopt,R1);
evlmi=evallmi(LMISYS,xopt);
[lhs,rhs]=showlmi(evlmi,4);
lhs
P
eigP=eig(P)
R1
eigR1=eig(R1)
eigsLHS=eig(lhs)
BTP=B'*P
BTPB=B'*P*B
invBTPB=inv(B'*P*B)
% recalculate
Geq=inv(B'*P*B)*B'*P
A0hat=A0-B*G*A0
A1hat=A1-B*G*A1
G= place(A0hat,B,[-4.5 -3])
A0til=A0hat-B*G1
eigA0til=eig(A0til)
eigA0hat=eig(A0hat)
eigA1hat=eig(A1hat)

```

```

ii = 1;
setlmis([])
P =lmivar(1,[2 1]);
R1=lmivar(1,[2 1]);
R2=lmivar(1,[2 1]);
lmiterm([-1 1 1 P],ii,ii)
lmiterm([-2 1 1 R1],ii,ii)
lmiterm([4 1 1 P],1,A0til,'s')
lmiterm([4 1 1 R1],ii,ii)
lmiterm([4 2 2 R1],-ii,ii)
lmiterm([4 1 2 P],1,A1hat)
LMISYS=getlmis;
[copt,xopt]=feasp(LMISYS);
P=dec2mat(LMISYS,xopt,P);
R1=dec2mat(LMISYS,xopt,R1);
evlmi=evallmi(LMISYS,xopt);
[lhs,rhs]=showlmi(evlmi,4);
lhs
P
eigP=eig(P)
R1
eigR1=eig(R1)
eigsLHS=eig(lhs)
BTP=B'*P
BTPB=B'*P*B
invBTPB=inv(B'*P*B)
normG1 = norm(G1)

```

A2

```

clear;
clc;
A0=[-1 0.7; 0.3 1];
A1=[-0.1 0.1; 0 0.2];
A2=[0.2 0; 0 0.1];
B=[1; 1]
setlmis([])
P =lmivar(1,[2 1]);
R1=lmivar(1,[2 1]);
R2=lmivar(1,[2 1]);
Geq=inv(B'*P*B)*B'*P
A0hat=A0-B*G*A0
A1hat=A1-B*G*A1
A2hat=A2-B*G*A2
G= place(A0hat,B,[-4.2-.6i -4.2+.6i])
A0til=A0hat-B*G1

```

```

eigA0til=eig(A0til)
eigA0hat=eig(A0hat)
eigA1hat=eig(A1hat)
eigA2hat=eig(A2hat)
ii = 1;
lmiterm([-1 1 1 P],ii,ii)
lmiterm([-2 1 1 R1],ii,ii)
lmiterm([-3 1 1 R2],ii,ii)
lmiterm([4 1 1 P],1,A0til,'s')
lmiterm([4 1 1 R1],ii,ii)
lmiterm([4 1 1 R2],ii,ii)
lmiterm([4 2 2 R1],-ii,ii)
lmiterm([4 1 2 P],1,A1hat)
lmiterm([4 1 3 P],1,A2hat)
lmiterm([4 3 3 R2],-ii,ii)
LMISYS=getlmis;
[copt,xopt]=feasp(LMISYS);
P=dec2mat(LMISYS,xopt,P);
R1=dec2mat(LMISYS,xopt,R1);
R2=dec2mat(LMISYS,xopt,R2);
evlmi=evallmi(LMISYS,xopt);
[lhs,rhs]=showlmi(evlmi,4);
lhs
eigsLHS=eig(lhs)
P
eigP=eig(P)
R1
R2
eigR1=eig(R1)
eigR2=eig(R2)
BTP=B'*P
BTPB=B'*P*B
invBTPB=inv(B'*P*B)
% recalculate
Geq=inv(B'*P*B)*B'*P
A0hat=A0-B*G*A0
A1hat=A1-B*G*A1
A2hat=A2-B*G*A2
G= place(A0hat,B,[-4.2-.6i -4.2+.6i])
A0til=A0hat-B*G1
eigA0til=eig(A0til)
eigA0hat=eig(A0hat)
eigA1hat=eig(A1hat)
eigA2hat=eig(A2hat)
ii = 1;

```

```

setlmiis([])
P =lmivar(1,[2 1]);
R1=lmivar(1,[2 1]);
R2=lmivar(1,[2 1]);
lmiterm([-1 1 1 P],ii,ii)
lmiterm([-2 1 1 R1],ii,ii)
lmiterm([-3 1 1 R2],ii,ii)
lmiterm([4 1 1 P],1,A0til', 's')
lmiterm([4 1 1 R1],ii,ii)
lmiterm([4 1 1 R2],ii,ii)
lmiterm([4 2 2 R1],-ii,ii)
lmiterm([4 1 2 P],1,A1hat)
lmiterm([4 1 3 P],1,A2hat)
lmiterm([4 3 3 R2],-ii,ii)
LMISYS=getlmiis;
[copt,xopt]=feasp(LMISYS);
P=dec2mat(LMISYS,xopt,P);
R1=dec2mat(LMISYS,xopt,R1);
R2=dec2mat(LMISYS,xopt,R2);
evlmi=evallmi(LMISYS,xopt);
[lhs,rhs]=showlmi(evlmi,4);
lhs
eigsLHS=eig(lhs)
P
eigP=eig(P)
R1
R2
eigR1=eig(R1)
eigR2=eig(R2)
BTP=B'*P
BTPB=B'*P*B
invBTPB=inv(B'*P*B)
normG1 = norm(G1)

A3
clear;
clc;
A0=[-0.228 2.148 -0.021 0; -1 -0.0869 0 0.039; 0.335 -4.424 -1.184 0; 0 0 1 0];
A1=[0 0 -0.002 0; 0 0 0 0.004; 0.034 -0.442 0 0; 0 0 0 0];
B=[-1.169 0.065; 0.0223 0; 0.0547 2.120; 0 0];
setlmiis([])
P =lmivar(1,[4 1]);
R1=lmivar(1,[4 1]);
G=inv(B'*P*B)*B'*P
A0hat=A0-B*G*A0

```

```

A1hat=A1-B*G*A1
G1= place(A0hat,B,[-.5+.082i -.5-.082i -.2 -.3])
A0til=A0hat-B*G1
eigA0til=eig(A0til)
eigA0hat=eig(A0hat)
eigA1hat=eig(A1hat)
%break
ii = 1;
lmiterm([-1 1 1 P],ii,ii)
lmiterm([-2 1 1 R1],ii,ii)
lmiterm([4 1 1 P],1,A0til,'s')
lmiterm([4 1 1 R1],ii,ii)
lmiterm([4 2 2 R1],-ii,ii)
lmiterm([4 1 2 P],1,A1hat)
LMISYS=getlmis;
[copt,xopt]=feasp(LMISYS);
P=dec2mat(LMISYS,xopt,P);
R1=dec2mat(LMISYS,xopt,R1);
evlmi=evallmi(LMISYS,xopt);
[lhs,rhs]=showlmi(evlmi,4);
lhs
P
eigP=eig(P)
R1
eigR1=eig(R1)
eigsLHS=eig(lhs)
BTP=B'*P
BTPB=B'*P*B
invBTPB=inv(B'*P*B)
gnorm=norm(G)

```

```

A4
clear;
clc;
A0=[2 0 1; 1.75 0.25 0.8; -1 0 1]
A1=[-1 0 0; -0.1 0.25 0.2; -0.2 4 5]
B =[0;0;1]
%break
h1=1.0;
setlmis([]);
P=lmivar(1,[3 1]);
Geq=inv(B'*P*B)*B'*P
A0hat=A0-B*Geq*A0
A1hat=A1-B*Geq*A1
eigA0hat=eig(A0hat)
eigA1hat=eig(A1hat)

```

```

DesPol = [-2.7 -.8+.5i -.8-.5i];
G= place(A0hat,B,DesPol)
A0til=A0hat-B*G
eigA0til=eig(A0til)
R1=lmivar(1,[3 1]);
S1=lmivar(1,[3 1]);
T1=lmivar(1,[3 1]);
lmiterm([-1 1 1 P],1,1);
lmiterm([-1 2 2 R1],1,1);
lmiterm([-2 1 1 S1],1,1);
lmiterm([-3 1 1 T1],1,1);
lmiterm([4 1 1 P],[A0til+A1hat]',1,'s');
lmiterm([4 1 1 S1],h1,1);
lmiterm([4 1 1 R1],h1,1);
lmiterm([4 1 1 T1],1,1);
lmiterm([4 1 2 P],-1,A1hat*A0hat);
lmiterm([4 1 3 P],-1,A1hat*A1hat);
lmiterm([4 2 2 R1],-1/h1,1);
lmiterm([4 3 3 S1],-1/h1,1);
lmiterm([4 4 4 T1],-1,1);
LMISYS=getlmis;
[copt,xopt]=feasp(LMISYS);
P=dec2mat(LMISYS,xopt,P);
R1=dec2mat(LMISYS,xopt,R1);
S1=dec2mat(LMISYS,xopt,S1);
T1=dec2mat(LMISYS,xopt,T1);
evlmi=evallmi(LMISYS,xopt);
[lhs,rhs]=showlmi(evlmi,4);
lhs,h1,P,R1,S1,T1
eigsLHS=eig(lhs)
% repeat
clc;
Geq=inv(B'*P*B)*B'*P
A0hat=A0-B*Geq*A0
A1hat=A1-B*Geq*A1
eigA0hat=eig(A0hat)
eigA1hat=eig(A1hat)
G= place(A0hat,B,DesPol)
A0til=A0hat-B*G
eigA0til=eig(A0til)
setlmis([]);
P=lmivar(1,[3 1]);
R1=lmivar(1,[3 1]);
S1=lmivar(1,[3 1]);
T1=lmivar(1,[3 1]);

```

```

lmiterm([-1 1 1 P],1,1);
lmiterm([-1 2 2 R1],1,1);
lmiterm([-2 1 1 S1],1,1);
lmiterm([-3 1 1 T1],1,1);
lmiterm([4 1 1 P],[A0til+A1hat]',1,'s');
lmiterm([4 1 1 S1],h1,1);
lmiterm([4 1 1 R1],h1,1);
lmiterm([4 1 1 T1],1,1);
lmiterm([4 1 2 P],-1,A1hat*A0hat);
lmiterm([4 1 3 P],-1,A1hat*A1hat);
lmiterm([4 2 2 R1],-1/h1,1);
lmiterm([4 3 3 S1],-1/h1,1);
lmiterm([4 4 4 T1],-1,1);
LMISYS=getlmis;
[copt,xopt]=feasp(LMISYS);
P=dec2mat(LMISYS,xopt,P);
R1=dec2mat(LMISYS,xopt,R1);
S1=dec2mat(LMISYS,xopt,S1);
T1=dec2mat(LMISYS,xopt,T1);
evlmi=evallmi(LMISYS,xopt);
[lhs,rhs]=showlmi(evlmi,4);
lhs,h1,P,R1,S1,T1
eigLHS=eig(lhs)
NormP=norm(P)
G
NormG = norm(G)
invBtPB=inv(B'*P*B)
BtP=B'*P
eigP=eig(P)
eigR1=eig(R1)
eigS1=eig(S1)
eigT1=eig(T1)

A5
clear; clc;
A0=[-4 0; -1 -3];
A1=[-1.5 0; -1 -0.5];
B =[ 2; 2];
h1=2.0000;
setlmis([]);
P=lmivar(1,[2 1]);
Geq=inv(B'*P*B)*B'*P
A0hat=A0-B*Geq*A0
A1hat=A1-B*Geq*A1
eigA0hat=eig(A0hat)

```

```

eigA1hat=eig(A1hat)
% DesPol = [-.8+.5i -.8-.5i]; G= place(A0hat,B,DesPol);
avec = [2 0.1];
G = avec;
A0til=A0hat-B*G1
eigA0til=eig(A0til)
R1=lmivar(1,[2 1]);
S1=lmivar(1,[2 1]);
T1=lmivar(1,[2 1]);
lmiterm([-1 1 1 P],1,1);
lmiterm([-1 2 2 R1],1,1);
lmiterm([-2 1 1 S1],1,1);
lmiterm([-3 1 1 T1],1,1);
lmiterm([4 1 1 P],[A0til+A1hat]',1,'s');
lmiterm([4 1 1 S1],h1,1);
lmiterm([4 1 1 R1],h1,1);
lmiterm([4 1 1 T1],1,1);
lmiterm([4 1 2 P],-1,A1hat*A0hat);
lmiterm([4 1 3 P],-1,A1hat*A1hat);
lmiterm([4 2 2 R1],-1/h1,1);
lmiterm([4 3 3 S1],-1/h1,1);
lmiterm([4 4 4 T1],-1,1);
LMISYS=getlmis;
[copt,xopt]=feasp(LMISYS);
P=dec2mat(LMISYS,xopt,P);
R1=dec2mat(LMISYS,xopt,R1);
S1=dec2mat(LMISYS,xopt,S1);
T1=dec2mat(LMISYS,xopt,T1);
evlmi=evallmi(LMISYS,xopt);
[lhs,rhs]=showlmi(evlmi,4);
lhs,h1,P,R1,S1,T1
eigsLHS=eig(lhs)
% repeat
Geq=inv(B*P*B)*B'*P
A0hat=A0-B*Geq*A0
A1hat=A1-B*Geq*A1
eigA0hat=eig(A0hat)
eigA1hat=eig(A1hat)
G = avec;
A0til=A0hat-B*G
eigA0til=eig(A0til)
setlmis([]);
P=lmivar(1,[2 1]);
R1=lmivar(1,[2 1]);
S1=lmivar(1,[2 1]);

```



```

T1=lmivar(1,[2 1]);
lmiterm([-1 1 1 P],1,1);
lmiterm([-1 2 2 R1],1,1);
lmiterm([-2 1 1 S1],1,1);
lmiterm([-3 1 1 T1],1,1);
lmiterm([4 1 1 P],[A0til+A1hat]',1,'s');
lmiterm([4 1 1 S1],h1,1);
lmiterm([4 1 1 R1],h1,1);
lmiterm([4 1 1 T1],1,1);
lmiterm([4 1 2 P],-1,A1hat*A0hat);
lmiterm([4 1 3 P],-1,A1hat*A1hat);
lmiterm([4 2 2 R1],-1/h1,1);
lmiterm([4 3 3 S1],-1/h1,1);
lmiterm([4 4 4 T1],-1,1);
LMISYS=getlmis;
[copt,xopt]=feasp(LMISYS);
P=dec2mat(LMISYS,xopt,P);
R1=dec2mat(LMISYS,xopt,R1);
S1=dec2mat(LMISYS,xopt,S1);
T1=dec2mat(LMISYS,xopt,T1);
evlmi=evallmi(LMISYS,xopt);
[lhs,rhs]=showlmi(evlmi,4);
lhs,h1,P,R1,S1,T1
eigsLHS=eig(lhs)
NormP=norm(P)
G
NormG = norm(G)
invBtPB=inv(B'*P*B)
BtP=B'*P
eigsP=eig(P)
eigsR1=eig(R1)
eigsS1=eig(S1)
eigsT1=eig(T1)

```

8. References

- Utkin, V. I. (1977), Variable structure system with sliding modes, *IEEE Transactions on Automatic Control*, Vol. 22, pp. 212-222.
- Sabanovic, A.; Fridman, L. & Spurgeon, S. (Editors) (2004). *Variable Structure Systems: from Principles to Implementation*, The Institution of Electrical Engineering, London.
- Perruquetti, W. & Barbot, J. P. (2002). *Sliding Mode Control in Engineering*, Marcel Dekker, New York.
- Richard J. P. (2003). Time-delay systems: an overview of some recent advances and open problems, *Automatica*, Vol. 39, pp. 1667-1694.

- Young, K. K. O.; Utkin, V. I. & Özgüner, Ü. (1999). A control engineer's guide to sliding mode control, *Transactions on Control Systems Technology*, Vol. 7, No. 3, pp. 328-342.
- Spurgeon, S. K. (1991). Choice of discontinuous control component for robust sliding mode performance, *International Journal of Control*, Vol. 53, No. 1, pp. 163-179.
- Choi, H. H. (2002). Variable structure output feedback control design for a class of uncertain dynamic systems, *Automatica*, Vol. 38, pp. 335-341.
- Jafarov, E. M. (2009). *Variable Structure Control and Time-Delay Systems*, Prof. Nikos Mastorakis (Ed.), 330 pages, A Series of Reference Books and Textbooks, WSEAS Press, ISBN: 978-960-474-050-5.
- Shyu, K. K. & Yan, J. J. (1993). Robust stability of uncertain time-delay systems and its stabilization by variable structure control, *International Journal of Control*, Vol. 57, pp. 237-246.
- Koshkouei, A. J. & Zinober, A. S. I. (1996). Sliding mode time-delay systems, *Proceedings of the IEEE International Workshop on Variable Structure Control*, pp. 97-101, Tokyo, Japan.
- Luo, N.; De La Sen N. L. M. & Rodellar, J. (1997). Robust stabilization of a class of uncertain time-delay systems in sliding mode, *International Journal of Robust and Nonlinear Control*, Vol. 7, pp. 59-74.
- Li, X. & De Carlo, R. A. (2003). Robust sliding mode control of uncertain time-delay systems, *International Journal of Control*, Vol. 76, No. 1, pp. 1296-1305.
- Gouisbaut, F.; Dambrine, M. & Richard, J. P. (2002). Robust control of delay systems: a sliding mode control design via LMI, *Systems and Control Letters*, Vol. 46, pp. 219-230.
- Fridman, E.; Gouisbaut, F.; Dambrine, M. & Richard, J. P. (2003). Sliding mode control of systems with time-varying delays via descriptor approach, *International Journal of Systems Science*, Vol. 34, No. 8-9, pp. 553-559.
- Cao, J.; Zhong, S. & Hu, Y. (2007). Novel delay-dependent stability conditions for a class of MIMO networked control systems with nonlinear perturbation, *Applied Mathematics and Computation*, doi: 10.1016/j.amc.2007.05.013, pp. 1-13.
- Jafarov, E. M. (2005). Robust sliding mode controllers design techniques for stabilization of multivariable time-delay systems with parameter perturbations and external disturbances, *International Journal of Systems Science*, Vol. 36, No. 7, pp. 433-444.
- Hung, J. Y.; Gao, & Hung, W. J. C. (1993). Variable structure control: a survey, *IEEE Transactions on Industrial Electronics*, Vol. 40, No. 1, pp. 2 - 22.
- Xu, J.-X.; Hashimoto, H.; Slotine, J.-J. E.; Arai, Y. & Harashima, F. (1989). Implementation of VSS control to robotic manipulators-smoothing modification, *IEEE Transactions on Industrial Electronics*, Vol. 36, No. 3, pp. 321-329.
- Tan, S.-C.; Lai, Y. M.; Tse, C. K.; Martinez-Salamero, L. & Wu, C.-K. (2007). A fast-response sliding-mode controller for boost-type converters with a wide range of operating conditions, *IEEE Transactions on Industrial Electronics*, Vol. 54, No. 6, pp. 3276-3286.

- Li, H.; Chen, B.; Zhou, Q. & Su, Y. (2010). New results on delay-dependent robust stability of uncertain time delay systems, *International Journal of Systems Science*, Vol. 41, No. 6, pp. 627-634.
- Schmidt, L. V. (1998). *Introduction to Aircraft Flight Dynamics*, AIAA Education Series, Reston, VA.
- Jafarov, E. M. (2008). Robust delay-dependent stabilization of uncertain time-delay systems by variable structure control, *Proceedings of the International IEEE Workshop on Variable Structure Systems VSS'08*, pp. 250-255, June 2008, Antalya, Turkey.
- Jafarov, E. M. (2009). Robust sliding mode control of multivariable time-delay systems, *Proceedings of the 11th WSEAS International Conference on Automatic Control, Modelling and Simulation*, pp. 430-437, May-June 2009, Istanbul, Turkey.

IntechOpen

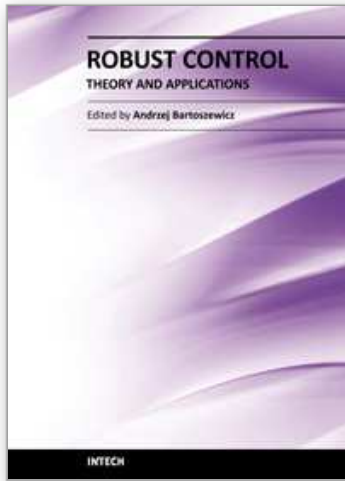

Robust Control, Theory and Applications

Edited by Prof. Andrzej Bartoszewicz

ISBN 978-953-307-229-6

Hard cover, 678 pages

Publisher InTech

Published online 11, April, 2011

Published in print edition April, 2011

The main objective of this monograph is to present a broad range of well worked out, recent theoretical and application studies in the field of robust control system analysis and design. The contributions presented here include but are not limited to robust PID, H-infinity, sliding mode, fault tolerant, fuzzy and QFT based control systems. They advance the current progress in the field, and motivate and encourage new ideas and solutions in the robust control area.

How to reference

In order to correctly reference this scholarly work, feel free to copy and paste the following:

Elbrous M. Jafarov (2011). Robust Delay-Independent/Dependent Stabilization of Uncertain Time-Delay Systems by Variable Structure Control, Robust Control, Theory and Applications, Prof. Andrzej Bartoszewicz (Ed.), ISBN: 978-953-307-229-6, InTech, Available from: <http://www.intechopen.com/books/robust-control-theory-and-applications/robust-delay-independent-dependent-stabilization-of-uncertain-time-delay-systems-by-variable-structu>

INTECH
open science | open minds

InTech Europe

University Campus STeP Ri
Slavka Krautzeka 83/A
51000 Rijeka, Croatia
Phone: +385 (51) 770 447
Fax: +385 (51) 686 166
www.intechopen.com

InTech China

Unit 405, Office Block, Hotel Equatorial Shanghai
No.65, Yan An Road (West), Shanghai, 200040, China
中国上海市延安西路65号上海国际贵都大饭店办公楼405单元
Phone: +86-21-62489820
Fax: +86-21-62489821

© 2011 The Author(s). Licensee IntechOpen. This chapter is distributed under the terms of the [Creative Commons Attribution-NonCommercial-ShareAlike-3.0 License](#), which permits use, distribution and reproduction for non-commercial purposes, provided the original is properly cited and derivative works building on this content are distributed under the same license.

IntechOpen

IntechOpen