

We are IntechOpen, the world's leading publisher of Open Access books Built by scientists, for scientists

5,300

Open access books available

132,000

International authors and editors

160M

Downloads

Our authors are among the

154

Countries delivered to

TOP 1%

most cited scientists

12.2%

Contributors from top 500 universities



WEB OF SCIENCE™

Selection of our books indexed in the Book Citation Index
in Web of Science™ Core Collection (BKCI)

Interested in publishing with us?
Contact book.department@intechopen.com

Numbers displayed above are based on latest data collected.
For more information visit www.intechopen.com



Phytoplankton Biomass Impact on the Lake Water Quality

Ozden Fakioglu

Additional information is available at the end of the chapter

<http://dx.doi.org/10.5772/55361>

1. Introduction

Phytoplankton is a plant plankton which cannot move actively and changes location depending on the movement of water. Phytoplankton communities are widely spreaded from aquatic to terrestrial lands. Plankton form the first ring of food chain in aquatic environment effecting the efficiency of this environment. Daily, seasonally and yearly changes are important for calculating efficiency in aquatic fields. Phytoplankton composition is a trophic indication of the water mass. In addition, phytoplankton species are used as an indicator for determining the nutrient level which is the basis for preparing and monitoring the strategies of the lake management in the lakes. Using phytoplankton communities or other aquatic organisms for evaluating water quality is based on very ancient times. Saprobic and trophic indicator types are used in many researches [1-3]. In addition, various numerical indices have been developed [1-2]. However, none of them have been accepted extensively. This is caused by several reasons. Those reasons are:

- a. Differences in phytoplankton groups and group concept
- b. Dynamic properties of phytoplankton groups
- c. Habitat diversity of freshwater ecosystems
- d. Phylogeographical differences [4].

Phytoplankton communities are influenced by significant changes every year. The competitive environment known as seasonal succession has been changing [5]. If the conditions don't change, this process results in the choice of communities dominated by one or more species. Phytoplankton responds rapidly to the condition changes. Conditional changes will result the formation of high compositional diversity [6].

The first approaches to classify algal communities don't have wide range of application in determining water quality. Pankin's approaches to classify algal communities in 1941 and 1945 weren't generally accepted [4]. Reynold's [7-8] applied a classic phytosociological

approach to phytoplankton data obtained from the lakes in northeast England and classified them into various communities. Sommer [5] found high similarities among the compositions of species and seasonal succession of Alpine lakes. Mason [9] reported that oligotrophic and eutrophic lakes have the communities of characteristic phytoplankton.

There are qualitative differences among phytoplankton communities in oligotrophic and eutrophic lakes. The composition and the amount of phytoplankton communities are affected by environmental conditions. For example, a numerical decrease is observed in *Anabaena* and *Aphanizomenon* species from heterocyst blue-green algae found in mesotrophic lake layers with a decrease of nitrogen saturation in the lakes. In addition, there are differences among the environmental conditions preferred by *Diatoms*, *Dinoflagellate* or *Cosmarium*, *Pandorina* and *Gemmellicystis* species, even though they can be found in the lakes with same level of nutrients [10].

In the works related with phytoplankton communities used for predicting the ecological structure of aquatic systems, it has been tried to develop functional groups by improving the systematic investigation. Furthermore, some indices were developed according to numerical and biovolume values of phytoplankton (Palmer Index (1969), Descy Index (1979), TDI Index (1995) etc.). HPLC pigment analysis is used for the diagnosis of phytoplankton species in recent years [11].

The methods we will mention for examination of plankton in aquatic environments are summarized by compiling researchers' methods and techniques. The main target of these suggested methods is to obtain values close to the actual volume and weight of plankton in freshwater and to calculate the volume and weight (biomass) of these organisms by this method.

Besides, the methods and techniques in this subject are sensitive, determining ecological parameters which are characterizing the aquatic environment are important for the researches. Sampling error in this review may cause errors far beyond the susceptibility of calculations. In addition, vertically and horizontally distributions of plankton may show big changes against the effects of wind and light. For this reason, evaluating various samples collected as vertically and horizontally causes to get more reliable results from each sample.

Many techniques have been developed depending on the number, volume and cell structures of fresh water phytoplankton. In this section, studies conducted by calculating biovolume of phytoplankton used for estimating ecological characteristics of freshwater ecosystems will be summarized.

2. Changes in biomass of phytoplankton in lakes

The composition and biomass of phytoplankton are very important parameters for understanding the structure and trophic level of aquatic systems. Phytoplankton cell size, carbon content and functional structure are investigated by many researchers. Phytoplankton communities can have cell size from a few microns to a few millimeters depending on the groups they belong to. Biovolume measurements are estimated by

automatic or semi-automatic methods. For example, morphometric methods, holographic method etc. In addition to these, the commonly used one is geometric method [12]. In addition to these methods, the most common method for calculating biomass is measuring chlorophyll *a* value. Chlorophyll *a* is an important photosynthetic pigment for plant organisms. Environmental factors affect the amount of ambient phytoplankton and chlorophyll *a* value changes depending on the amount of phytoplankton [13].

Coulter Counter method is based on measuring electrical conductivity among cells. Electric current flowing through the cells placed in physiological saline varies depending on the cell size. Thus, the cell size is determined.

Morphometric methods is used in determining the quantitative properties of cells. With this method, cell density is calculated depending on cell wall, chloroplast, vacuole, depot material and cytoplasmic content [14].

Holographic scanning technology which is used in conjunction with one curved mirror to passively correct focal plane position errors and spot size changes caused by the wavelength instability of laser diodes [15].

Geometric method is based on estimating biomass of phytoplankton via geometric shapes and mathematical equations. This model was found by Kovada and Larrance. 20 geometric models developed by Hillebrand *et al.* [16] are used for calculating biomass of algae. Each model was designed depending on cell structure with the shapes like sphere, cone, triangle etc. This method was applied to phytoplankton species found in sea waters in China and 31 geometric models were developed in this study [12].

Phytoplankton communities show vertical changes from time to time. Chlorophyll *a* is a pigment used for estimating biomass of phytoplankton. Seasonal changes cause variation in chlorophyll *a* value. For this reason, water affects the production of column light transmittance, hence, the value of chlorophyll *a* [18]. In determining chlorophyll *a*, fiber glass filter papers used for filtering water samples are waited for 3-4 hours then they are decomposed and kept in 10 ml 90% acetone one night, centrifuged and optical density of the extract is made by reading from spectrophotometer with 630, 645 and 665 nm wavelength [17].

The first step for calculating phytoplankton biomass is to store and protect the phytoplankton samples.

3. Storing and protecting phytoplankton samples

Before collecting phytoplankton samples from the lake, turbidity and temperature of the water were measured by Secchi disk. Phytoplankton samples have to be stored in 100-150 ml glass or polyethylene containers with 2% Lugol's solution or 4% Buffere formalin solution [32].

4. Identification of phytoplankton

Water samples taken by phytoplankton scoop were identified according to world literature [19-29].

5. Phytoplankton counting

Water samples put into hydrobios plankton counting chambers depending on phytoplankton density, after standing overnight by dropping lugol's solution, counting phytoplankton were made by using inverted microscope [30-31].

Following formula was used to calculate the number of phytoplankton [31]:

$$\text{Number of phytoplankton (piece/ml)} = \frac{C \times TA}{F \times A \times V}$$

Here;

C= The number of organisms found by counting (number),

TA= Bottom area of the cell count (mm²),

F= Counted field number (number),

A= Field of view of the microscope (mm²),

V= Volume of precipitated sample (ml).

6. Estimation of phytoplankton biomass

Phytoplankton analysis is possible by a simple Kolkwitz chamber. Except deposited plankton in sample bottle, liquid at the top pour a few millilitres and centrifuged and their volumes are measured in sedimentation tubes then they are transferred to Kolkwitz chamber for analysis. In this method, phytoplankton analysis is the first, semi-field analysis of Kolkwitz chamber is the second and the third one is the analysis of the various fields.

Biovolume was estimated in the measurement of phytoplankton biomass. Phytoplankton were emulated to the geometric shapes like sphere, cylinder and cone and necessary measurements were taken from the phytoplankton while counting [32]. Geometric shapes and calculations used for calculating biovolume was done according to the formulas (Table 1) stated by [12] and [16]. After calculating average volume of every species, total volume were calculated by multiplying with the number of species. Following formula was used to calculate total cell volume of phytoplankton [31];

$$HH = \sum_{i=1}^n (HN_i \times SH_i)$$

Here;

HH= Total biovolume of plankton (mm/l),

HN_i= the number of organisms belongs to i. species /l,

SH_i= Average cell volume of i. species.

Biovolume is calculated by assuming cell volume is equal to 1mg age weight/m³ algal biovolume for 1mm/ m³ [33].

Shape	Biovolume	Samples
	$V = \frac{\pi}{6} \cdot a^3$	<i>Crucigeniella apiculata</i> <i>Gomphosphaeria</i> sp. <i>Anabeana</i> sp.
	$V = \frac{\pi}{6} \cdot b^2 \cdot a$	<i>Coelastrum microporum</i> <i>Actinastrum hantzschii</i> <i>Dinobryon divergens</i> <i>Cryptomonas</i> sp. <i>Pandorina</i> sp.
	$V = \frac{\pi}{6} \cdot a \cdot b \cdot c$	<i>Trachelomonas caudata</i> <i>Peridinium</i> sp. <i>Botryococcus braunii</i> <i>Cocconeis placentula</i> <i>Phacus tortus</i>
	$V = \frac{\pi}{4} \cdot a^2 \cdot c$	<i>Cyclotella</i> sp. <i>Mougeotia</i> sp.

Table 1. Geometrical shapes and formulas for calculating biovolume (continued)

Shape	Biovolume	Samples
	 $V = \pi \cdot b^2 \cdot \left(\frac{a}{4} - \frac{b}{12} \right)$	<i>Stephanopyxis</i> sp.
	 $V = \frac{\pi}{4} \cdot b^2 \cdot \left(a - \frac{b}{3} \right)$	<i>Stephanopyxis</i>
	 $V = \frac{\pi}{12} \cdot a \cdot b^2$	<i>Monoraphidium contortum</i> <i>Actinastrum hantzschii</i>
	 $V = \frac{\pi}{12} \cdot a \cdot b^2$	<i>Spiraulax</i> sp.

Table 1. Geometrical shapes and formulas for calculating biovolume (continued)

Shape	Biovolume	Samples
 	 $V = \frac{\pi}{4} \cdot b^2 \cdot a$  $V = a \cdot b \cdot c$	<p><i>Chroomonas</i> sp.</p> <p><i>Asterionella</i> sp. <i>Synedra</i> sp. <i>Merismopedia</i> sp. <i>Epithemia zebra</i> var. <i>saxonica</i></p>
   	 $V = \frac{\pi}{4} \cdot a \cdot b \cdot c$  $V = \frac{\pi}{4} \cdot a \cdot b \cdot c$  $V = \frac{1}{2} \cdot a \cdot b \cdot c$  $V = \frac{\pi}{4} \cdot a \cdot b \cdot c$	<p><i>Pediastrum</i> sp. <i>Navicula</i> sp.</p> <p><i>Cymatopleura</i> sp.</p> <p><i>Nitzschia</i> sp.</p> <p><i>Phaeodactylum</i> sp.</p>

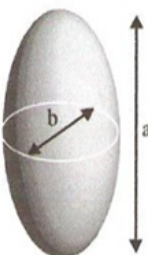
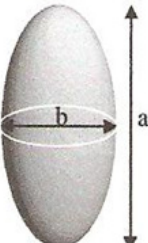
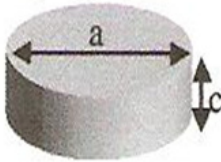
Table 1. Geometrical shapes and formulas for calculating biovolume (continued)

Shape	Biovolume	Samples
	 $V \cong \frac{\pi}{4} \cdot a \cdot b \cdot c$ $V \cong \frac{\pi}{6} \cdot a \cdot b^2$	<p><i>Monorophidium</i> sp. <i>Eunotia</i> sp.</p>
	 $V = a \cdot c^2 \cdot a \sin\left(\frac{b}{2c}\right)$	<p><i>Cymbella</i> sp. <i>Amphora ovalis</i> <i>Epithemia</i> sp. <i>Rhopalodia gibba</i></p>
	 $V = \frac{\sqrt{3}}{4} \cdot c \cdot a^2$	<p><i>Hydrosera</i> sp.</p>
	 $V = \frac{1}{6} \cdot a^2 \cdot c$	<p><i>Tetradinium</i></p>

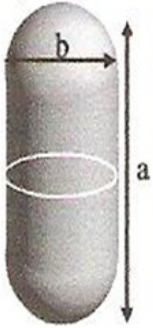
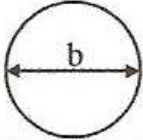
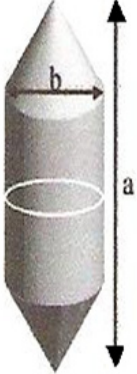
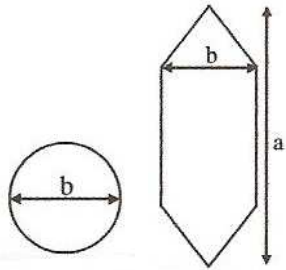
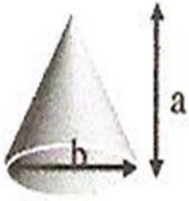
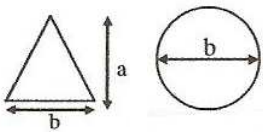
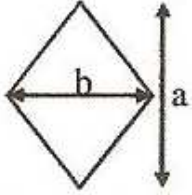
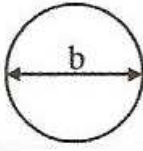
Table 1. Geometrical shapes and formulas for calculating biovolume (continued)

Shape	Biovolume	Samples
	$V \cong \frac{\pi}{4} \cdot a \cdot b \cdot c$	<i>Tabellaria</i> sp.
	$V \cong \frac{a \cdot b}{4} \cdot \left[a + \left(\frac{\pi}{4} - 1 \right) \cdot b \right] \cdot a \sin \left(\frac{c}{2a} \right)$	<i>Gomphonema constrictum</i>
	$V = \frac{\pi}{3} \cdot (a_1 + a_2) \cdot b_1^2 + \frac{\pi}{4} \cdot (a_2 + b_2) \cdot b_2^2 + \frac{\pi}{12} \cdot a_2 \cdot b_1 \cdot b_2$	<i>Euglena</i> sp.

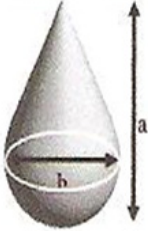
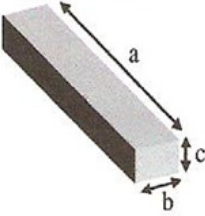
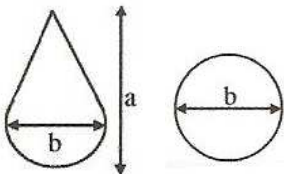
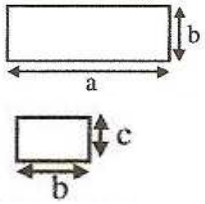
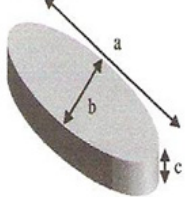
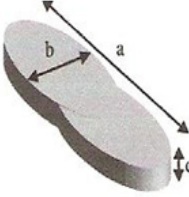
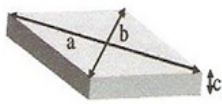
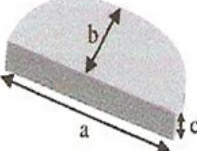
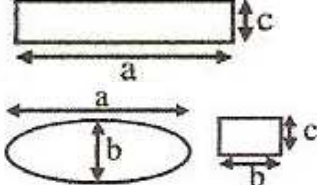
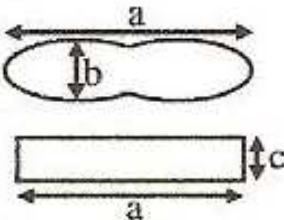
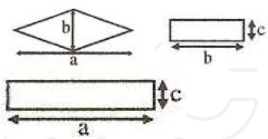
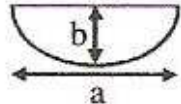
Table 1. Geometrical shapes and formulas for calculating biovolume (continued)

Shape	Biovolume	Samples	
		$V = \frac{\pi}{4} \cdot a_1 \cdot b_1 \cdot c_1 + \frac{\pi}{3} \cdot a_2 \cdot b_2^2$	<i>Climacodium</i> sp.
		$V \cong \frac{\pi}{4} \cdot a \cdot b \cdot c$	<i>Caloneis</i> sp.
		$V = \frac{\pi}{12} \cdot a^3$	<i>Cosmarium</i> sp.
		$b_2 = b_3 = b_4$ $V = \frac{\pi}{4} \cdot a_2 \cdot b_2^2 \cdot \frac{\pi}{12} \cdot (a_3 + a_4) \cdot b_2^2 + \frac{\pi}{6} \cdot a_1 \cdot b_1 \cdot b_2$	<i>Staurastrum</i> sp.

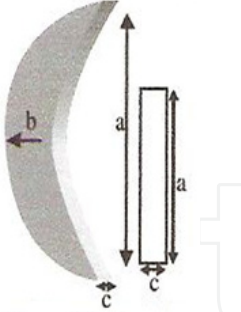
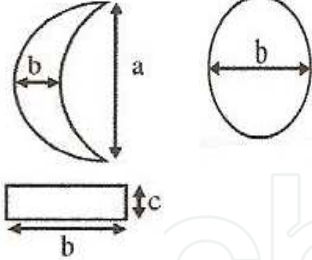
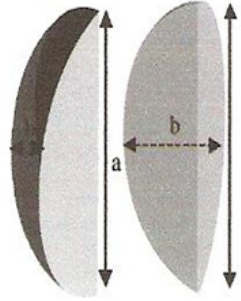
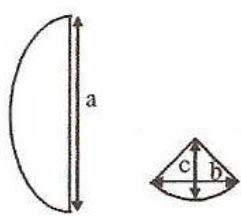
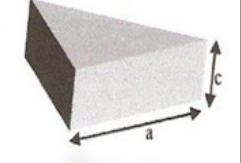
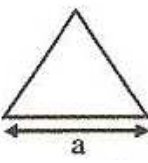
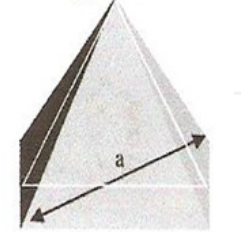
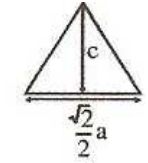
Table 1. Geometrical shapes and formulas for calculating biovolume (continued)

Shape	Biovolume	Samples
	 $V = \frac{\pi}{4} \cdot a_2 b_2^2 + \frac{\pi}{2} \cdot a_3 \cdot b_3^2 + \frac{\pi}{12} \cdot a_1 \cdot (b_1^2 + b_1 \cdot b_2 + b_2^2)$	<p><i>Ceratium hirundinella</i></p>
	 $V = \frac{\pi}{4} \cdot b^2 \cdot a$	<p><i>Pleurosira</i> sp.</p>
	 $V = \frac{\pi}{4} \cdot a \cdot b \cdot c$	<p><i>Fragilaria crotonensis</i></p>
	 $V = \frac{\sqrt{3}}{4} \cdot a \cdot b^2$	<p><i>Ditylum</i> sp.</p>

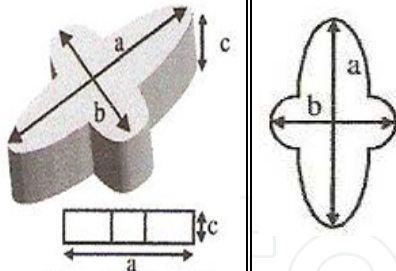
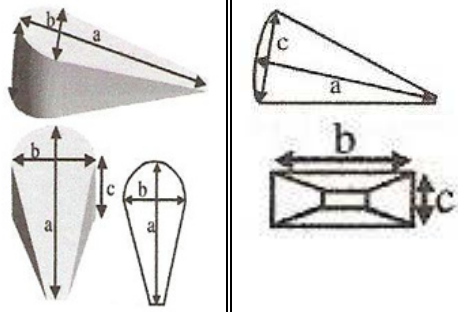
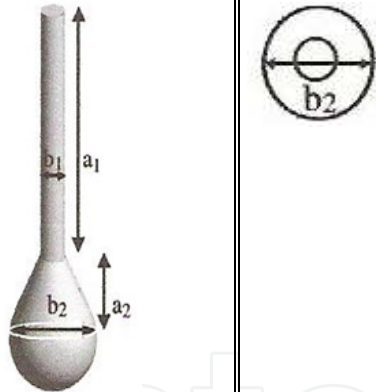
Table 1. Geometrical shapes and formulas for calculating biovolume (continued)

Shape	Biovolume	Samples
	$V \cong c \cdot \left(a_1 \cdot b_1 + \frac{\pi}{4} \cdot a_2 \cdot b_2 \right)$	<i>Climacosphenia</i> sp.

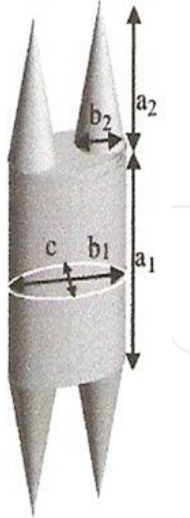
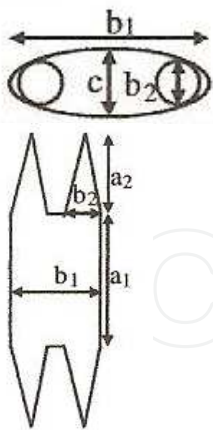
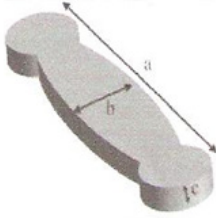
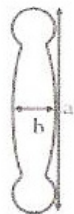
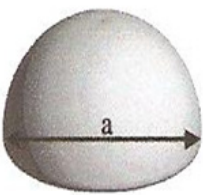
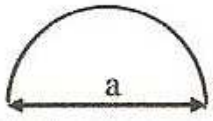
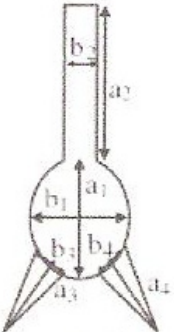
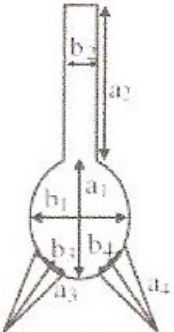
Table 1. Geometrical shapes and formulas for calculating biovolume (continued)

7. Case studies conducted to phytoplankton biomass

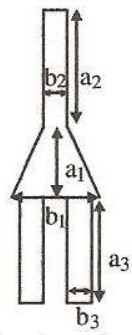
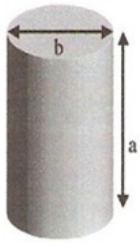
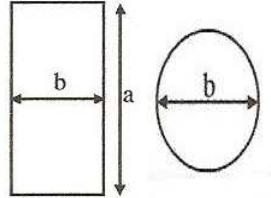
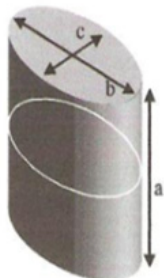
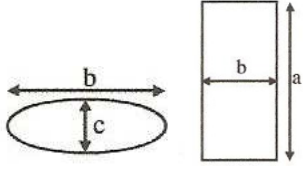
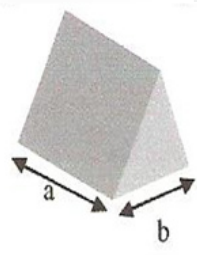
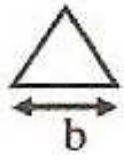
There is a significant correlation between biomass of phytoplankton with the concentration of phosphorus. Changes are seen in phytoplankton biomass or production rate with the changes of the concentration of phosphorus in the lakes. It has been showed in the field studies that light and temperature play a significant role in the relationship between the extinction rate and biomass and carrying capacity of the composition of species [34].

In a study conducted in Lake Erie, samples have been collected from three different points in spring, summer and fall season for five years; 49 species were determined at the end of the study [35].

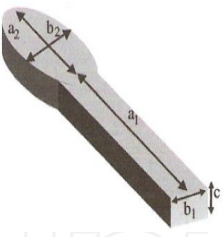
In a lake with 25000 km² surface area, phytoplankton biomass showed local changes and it was determined as 1.88 ± 0.12 g/m³, 1.04 ± 0.07 g/m³ and 0.63 ± 0.071 g/m³ in west, mid and east part of the lake respectively. It was determined that algal biomass decreased and biomasses of *Aphanizomenon flos-aque*, *Stephanodiscus binderounus*, *S. niagarae*, *S. tenuis*, *Rhodomonas minuta* decreased in the rate of 70-98% from 1970 to 1983-1987 [35].

Phytoplankton communities and distributions were investigated from the samples taken weekly from two dam lake with different nutrient levels in Sicily. Lake Arancio is a shallow eutrophic lake and Lake Rosamarina is a deep mezotrofik lake. It was stated that the increment in the concentration of nutrients in Lake Arancio doesn't change the composition of phytoplankton but increase biomass of phytoplankton [36].

In a study examining 27 lakes in Russia; plankton biomass and total phosphorus concentration were investigated and it is stated that total phosphorus concentration changes between 10-137 mg/m³ and biomass changes between 0.4-20 g/m³. Total 160 phytoplankton species were identified and it was reported that most of those are belong to the blue-green algae and euglenophyceae classes. The lakes were determined to be hypertrophic and acidic [37].

In a study conducted with Lake Dorani, it was determined that the most common class in the lake was chlorophyceae followed by cyanophyceae. Total phytoplankton biomass is found similar to eutrophic lakes. While, nanoplankton biomass constitute 90% of total phytoplankton biomass in spring but it is 10% throughout the year. It is found that total biomass is high in summer, low in winter and changes between 0.43-30.30 mg/l [38].

Seasonal changes of phytoplankton communities in Lake Managua are investigated, it is reported that blue-green algae are dominant during the research period. Seasonal biomass are measured monthly for two years and the lowest phytoplankton biomass was found at the end of the rainy seasons (October, November). In short term studies (3-14 days), important changes in biomass were reported. Nutrient levels of the lake were estimated as hypertrophic according to chlorophyll *a* value (79 µg/l yearly average, 1987-1988) [39].

During the research conducted with Lake Beysehir, diatoms and green algae are found dominant. throughout the research *Aulacoseira granulata* and *Cyclotella meneghiniana* from centric diatom, *Asterionella formosa*, *Cocconeis placentula*, *Cymbella affinis* and *Ulnaria acus* from pennate diatoms, *Monoraphidium* spp., *Mougeotia* sp. and *Scenedesmus linearis* from Chlorophyta, *Dinobryon divergens* from Chrysophyta and *Cryptomonas marssonii*, *Rhodomonas lacustris* from Cryptophyta, *Merismopedia glauca* from Cyanophyta are commonly found and partly numerical increases are observed. Phytoplankton biomass in the lake changes between 0.40 ± 0.11 and 6.43 ± 1.00 mg/l. The lake is in mesotrophic nutrients level according to average phytoplankton biomass (1.98 ± 0.2 mg/l) and it is in good ecological quality class [40].

8. Results and suggestions

When the comparison was made between geometrical and other models, geometrical model is used more. Trials for other models in computer environment still continue. Techniques used for calculating biomass have some advantages and disadvantages. For example, *Strombomonas gibberosa* is phytoplankton with complex shape. For this reason, some different opinions arise for choosing proper geometric shape for calculating biovolume.

Three problem stands out in the estimation of biomass.

1. The shapes of phytoplankton cells has irregular and complex structure which makes it hard to measure them under microscope
2. Cell dimensions changes in the study of dead cells. In addition, it makes hard to determine chloroplast and vacuollarin.
3. Physiological state of a cell (light, temperature, nutrient) may affect cell height and intracellular volume [14].

Calculating biomass is important for determining ecological status of aquatic ecosystems. There is a relationship between cell structure of phytoplankton communities and many Physico-chemical parameters. For this reason, physical and chemical changes of water have to be considered in biomass calculaions.

Since some species show physiological changes with the changes in environmental conditions, characteristics of phytoplankton groups should be well known. In some species in group of cyanobacteria, fringes observed depending on the increase of the value of nitrogen and phosphorus in the medium. This causes changes in cell dimensions. For this reason, it is suggested to support biomass usage for classifying freshwater ecological systems with physico-chemical parameters.

Author details

Ozden Fakioglu
Atatürk University, Turkiye

Acknowledgement

The author would like to acknowledge Prof. Nilsun DEMİR and Prof. Muhammed ATAMALP for their insightful comments on this chapter.

9. References

- [1] Thunmark S (1945) Zur Soziologie Des Süßwasserplankton. Eine Methodisch-Ökologische Studie. Folia Limnologica Skandinavica. 3; 1–66.
- [2] Nygaard G (1949) Hidrobiological studies on some Danish ponds and lakes. Part II: The quotient hypothesis and some little known plankton organisms. Kongelige Danske Videnskaberne Selskab Biologiske Skrifter 7; 1-293.
- [3] Lepistö L., Rosenström U (1998) The most typical phytoplankton taxa in four lakes in Finland. Hydrobiologia, 369/370; 89–97.
- [4] Padisak J, Grigorczyk I, Borics G, Soroczki-Pinter E (2006) Use of phytoplankton assemblages for monitoring ecological status of lakes within the Water Framework Directives: the assemblage index. Hydrobiologia, 1-14.
- [5] Sommer U (1986) The periodicity of phytoplankton in Lake Constance (Bodensee) in comparison to other deep lakes of central Europe. Hydrobiologia, 138; 1–7.
- [6] Scheffer M, Reinaldi S, Huisman J, Weissing FJ (2003) Why plankton communities have no equilibrium: solutions to the paradox. Hydrobiologia, 491; 9- 18.
- [7] Reynolds CS (1980) Phytoplankton assemblages and their periodicity in stratifying lake systems. Holarctic Ecology, 3; 141–159.
- [8] Reynolds CS (1997) Vegetation processes in the pelagic. Ecology Institute, Oldendorf/Luhe, Germany.
- [9] Mason CF (1991) Biology of Freshwater Pollution. 2nd ed. Longman, 351 s., Great Britain.
- [10] Reynolds C, Dokulil M, Padisak J (2000) Understanding the assembly of phytoplankton in relation to the trophic spectrum: where are now? Hydrobiologia, 424; 147-152.
- [11] Ediger D, Soydemir N, Kideys AE (2006) Estimation of Phytoplankton Biomass Using HPLC Pigment Analysis in the South-western Black Sea. Deep-sea Research II. 53: 1911-1922.
- [12] Sun J, Liu D (2003) Geometric models for calculating cell biovolume and surface area for phytoplankton. Journal of Phytoplankton Research. 25; 1331-1346.
- [13] Kayaalp GT, Polat S (2001) Tüm Gözlemlen ve Eksik Gözlemlen Regresyon Modelinde Klorofil-a miktarının tahmini. E.Ü. Su Ürünleri Dergisi, 18; 529-535.
- [14] Sicko-Goad L, Stoermer EF, Ladewski BG (1977) A Morphometric Method for Correcting Phytoplankton Cell Volume Estimates. Protoplasm. 93: 147-163.

- [15] Rowe DM (1997) Developments in Holographic-Based Scanner Designs, SPIE Conference on Optical Scanning System. San Diego, CA.
- [16] Hillebrand H, Dürselen CD, Kirschtel D, Pollinger U, Zohary T (1999) Biovolume calculation for pelagic and benthic microalgae, *J. Phycol.*, 35, 403-424.
- [17] Strickland JDH, Parsons TR (1972) A Practical Handbook Of Seawater Analysis. 2nd Ed. Bull. Fish. Res. Board. Can., p311, Canada.
- [18] Wetzel RG (2001) Limnology. 3rd Edition, Saunders College, 767 p., Philadelphia.
- [19] Hustedt F (1930) Bacillariophyta (Diatomeae). Heft 10. In: A. Pascher (Ed), Die Süßwasser-Flora Mitteleuropas, Verlag von Gustav Fisher, Jena, p466.
- [20] Huber-Pestalozzi G (1938) Das Phytoplankton des Süßwassers, 1 Teil. Blaualgen, Bakterien, Pilze. In: A. Thienemann (Ed), Die Binnengewässer, E. Schweizerbart'sche Verlagsbuchhandlung, 342 p., Stuttgart.
- [21] Huber-Pestalozzi G (1942) Das Phytoplankton des Süßwassers, 2 Teil. Diatomeen. In: A. Thienemann (Ed), Die Binnengewässer, E. Schweizerbart'sche Verlagsbuchhandlung, p549., Stuttgart.
- [22] Huber-Pestalozzi G (1950) Das Phytoplankton des Süßwassers, 3 Teil. Cryptophyceen, Chloromonadien, Peridineen. In: A. Thienemann (Ed), Die Binnengewässer, E. Schweizerbart'sche Verlagsbuchhandlung, 310 p., Stuttgart.
- [23] Cox EJ (1996) Identification of Freshwater Diatoms from Live Material. Chapman and Hall, p158, London.
- [24] Prescott GW (1973) Algae of the Western Great Lakes Area, 5th ed. WM. C. Brown Co. Publ, 977, Dubuque.
- [25] Lind ME, Brook AJ (1980) A key to the Commoner Desmids of the English Lake District. Freshwater Biol. Assoc. Publ., 123, Cumbria.
- [26] Komarek J, Fott B (1983) Chlorococcales, 7. Teil. 1.Hälfte. In: J. Elster and W. Ohle (Eds), Das Phytoplankton des Süßwassers, E. Schweizerbart'sche Verlagsbuchhandlung, p1043., Stuttgart.
- [27] Komarek J, Anagnostidis K (1999) Cyanoprokaryota 1. Teil: Chroococcales. In: H. Ettl, G. Gartner, H. Heynig, D. Mollenhauer (Eds), Süßwasserflora von Mitteleuropa, Spektrum Akademischer Verlag, p548., Heidelberg.
- [28] John DM, Whitton BA, Brook AJ (2002) The Freshwater Algal Flora of The British Isles. Cambridge Univ. Press, Cambridge, p702.
- [29] Popovski J, Pfiester LA (1990) Dinophyceae (Dinoflagellida), Band 6. In: H. Ettl, J. Gerloff, H. Heynig, D. Mollenhauer (Eds). Süßwasserflora von Mitteleuropa, Gustav Fisher Verlag, 243, Jena.
- [30] Utermöhl H (1958) Zur Vervollkommnung der quantitativen Phytoplankton-Methodik. Mitteilungen der Internationale Vereinigung der theoretische und Angewandte Limnologie, 5; 567-596.
- [31] Anonymous (1995) Standard Methods for the Examination of Water and Wastewater. 19th ed., American Public Health Association (APHA), p1193., Washington.
- [32] Wetzel RG, Likens GE (1991) Limnological Analysis. 2nd ed. Springer Verlag, New York.

- [33] Rott E (1981) Some results from phytoplankton counting intercalibrations. *Schweiz. Z. Hydrol.* 43; 34-59.
- [34] Heyman U, Lundgren A (1988) Phytoplankton biomass and production in relation to phosphorus. *Hydrobiologia*, 170; 211-227.
- [35] Makarewicz JC (1993) Phytoplankton Biomass and Species Composition in Lake Erie, 1970 to 1987. *J. Great Lakes Res*, 19(2); 258–274.
- [36] Naselli-Flores L, Barone R (1998) Phytoplankton dynamics in two reservoirs with different trophic state (Lake Rosamarina and Lake Arancio, Sicily, Italy) *Hydrobiologia*, 369/370; 163-178.
- [37] Trifonova IS (1998) Phytoplankton composition and biomass structure in relation to trophic gradient in some temperate and subarctic lakes of Northwestern Russia and the Prebaltic. *Hydrobiologia*, 369/370; 99–108,
- [38] Temponeras M, Kristiansen J, Moustaka-Gouni M (2000) Seasonal variation in phytoplankton composition and physical-chemical features of the shallow Lake Doirani, Macedonia, Greece *Hydrobiologia*, 424; 109–122.
- [39] Hooker E, Hernandez S (2006) Phytoplankton biomass in Lake Xolotlán (Mamagua): Its seasonal and horizontal distribution. *Aquatic Ecology*, 25 (2); 125–131.
- [40] Fakıoğlu O, Demir N (2011) The Spatial and Seasonal Variations of Phytoplankton Biomass in Beyşehir Lake. *Ekoloji*. 80; 23-32.