

We are IntechOpen, the world's leading publisher of Open Access books Built by scientists, for scientists

5,600

Open access books available

138,000

International authors and editors

170M

Downloads

Our authors are among the

154

Countries delivered to

TOP 1%

most cited scientists

12.2%

Contributors from top 500 universities



WEB OF SCIENCE™

Selection of our books indexed in the Book Citation Index
in Web of Science™ Core Collection (BKCI)

Interested in publishing with us?
Contact book.department@intechopen.com

Numbers displayed above are based on latest data collected.

For more information visit www.intechopen.com



Chromatography in Bioactivity Analysis of Compounds

Sylwester Czaplicki

Additional information is available at the end of the chapter

<http://dx.doi.org/10.5772/55620>

1. Introduction

Chromatographic techniques have led to considerable development in mixture ingredient analysis. With the development of stationary-phase and high-pressure module technologies, new possibilities have emerged for the separation of complex systems whose components are characterised by similar structures and properties. Modern detection systems now allow detection and identification of individual ingredients. Data on their electrical properties, characteristic ways of molecule ionisation, and their ability to absorb or emit electromagnetic waves are used for this purpose (among others). The possibilities offered by chromatographic techniques are also used to isolate mixture ingredients for further analysis or to compose mixtures with predesigned properties. Appropriate tests preceded by isolation of analysed ingredients from the biological matrix are applied to determine the characteristics of components of analysed biological samples. In some circumstances this can be very arduous because the separation process itself is time- and cost-consuming or it is necessary to have appropriate infrastructure. Preparative-scale chromatographic separation can be conducted using the techniques of preparative thin-layer chromatography (prep-TLC), preparative column chromatography (prep-LC) as well as preparative-scale high-performance liquid chromatography (prep-HPLC). Isolated fractions or purified compounds can serve as material for determination of their biological properties. Currently, researchers are greatly interested in methods of analysis and identification for compounds which are antioxidants or inhibitors of specific transformations in the biochemistry of living organisms. Ingredients isolated from the material are purified by solid-phase extraction (SPE), thin-layer chromatography (TLC), preparative column chromatography (prep-LC) and preparative-scale high performance liquid chromatography (prep-HPLC). The obtained compounds or fractions are the subject of research to determine their biological properties in tests with DPPH, ABTS, AAPH radicals, the Folin-Ciocalteu reagent, etc. This procedure is cost-, time- and labour-consuming and the obtained results may be uncertain. This uncertainty is connected with the fact that during

isolation, compounds are exposed to environmental factors such as oxygen, light, increased temperature. As a result the isolated compound may not have such a chemical structure as before isolation. This can cause a change in the biological activity of the examined substances. A combination of chromatographic ingredient separation methods with the detection of biochemical properties provides great possibilities for examination of the compounds present in complex biological systems. Methods have emerged which use the advantages of a solution to determine the ingredients of analysed mixtures with regard to both quality and the antioxidant activity detection. These methods have become very useful, e.g. during identification of the biological activity of plant extracts. The search for chemical compounds with desired biological properties by coupling chromatographic methods with biochemical detection has immense possibilities. The merits of this solution are currently used to an increasing extent.

This paper presents analysis methods for compounds to determine their general biological activity. Characteristics of the methods in model systems using different antioxidant reaction mechanisms are also described. Both colorimetric methods and those with fluorometric detection as well as chemiluminescence testing are included.

The main element in the paper is presentation of the possibilities for using the liquid chromatography technique for screening compounds with regard to their biological properties. Examples of different uses of chromatographic methods in on-line analysis of the bioactivity of mixture ingredients are also described.

2. Separation of components by means of gas chromatography

Chromatographic techniques are based on separation of substances between a stationary and a mobile phase. The mobile phase moves relative to the stationary one. Components of a mixture to be separated move together with the mobile phase due to their different interactions with the phases.

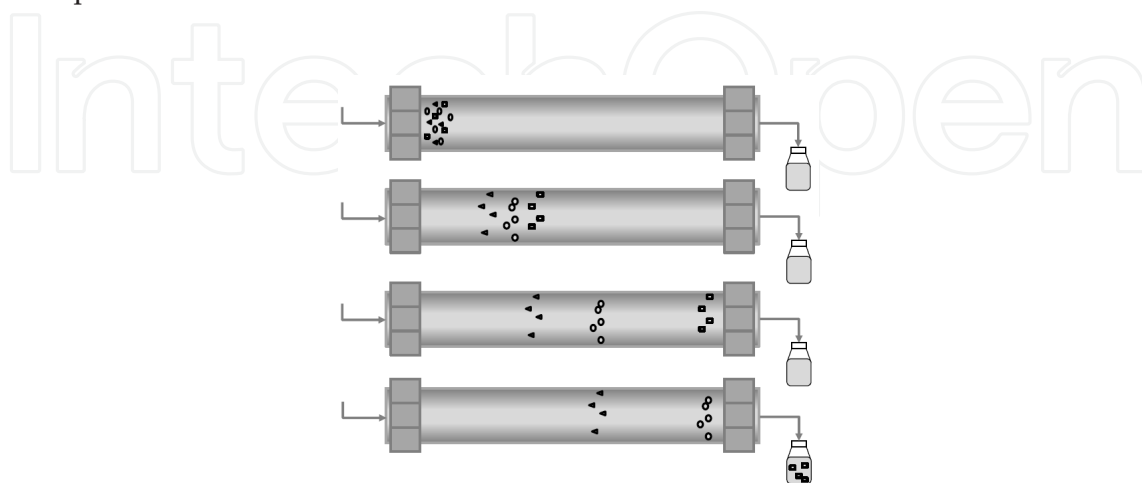

Figure 1. Separation of a compound on a chromatographic column

Depending on the technique applied, the stationary phase can be: column packing (column chromatography), thin layer of active substances put onto a plate (alumina or predominately silica gel) (thin-layer chromatography) or absorbent paper (paper chromatography). A mobile phase is a liquid which moves relative to the stationary phase. To be separable by this technique, components of a mixture must be soluble in the mobile phase. Depending on the interactions between the components and individual phases, the components move faster or more slowly together with the mobile phase along the stationary phase. The speed of movement depends on the strength of interactions between the components and each of the phases.

Such interactions cause sorption and desorption of the components from the mobile to the stationary phase. For the separation to be effective, the speeds of movement of components relative to the stationary phase must be different. The simplest solutions are based on free flow of solvent, but the system effectiveness can be improved by using pressurised flow. Upon leaving the chromatographic system, the separated components flow to detectors, where their specific properties are used to observe their presence, amount, and sometimes even to identify them. UV-Vis detectors, measuring absorbance of the solution which leaves a chromatographic column, are among the most widely-used devices. Components of a solution are observed as increased light absorption by the solution flowing through a quartz flow cell. With a detector of this type, it is possible to observe elution of individual mixture components on the “present-absent” basis. An analyst is presented with better capabilities when using a version of the detector with a photodiode matrix. Owing to a photodiode detector (PDA), it is possible to observe light absorption within the UV-Vis range at different wavelengths simultaneously. Moreover, it is possible to conduct observations of the absorption spectrum within a selected part of the UV and visible range. Owing to that property, it is possible to conduct simultaneous observation of elution of compounds which absorb light to a different extent at different wavelengths and, additionally, the detector is more selective. It is very important that identification of the separated compounds can be conducted based on the spectra. This is possible because individual compounds have specific absorption spectra depending on the bond structures and function groups. A less popular detection technique makes use of the ability of compounds to emit light. Fluorescence detectors are used where separated compounds specifically emit energy after their excitation. These detectors are highly selective and sensitive, which is essential when other mixture components are co-eluted with the substances being determined. In such cases, the detection parameters are set to make the excitation or emission wavelength match the analysed compounds. Mentioned detectors make use of the ability to absorb or emit light, but other detection techniques are also used depending on the properties of the analysed compounds. These include the following types of detectors: refractometric – the signal is measured as a change of the light refraction coefficient caused by optically active substances; electrochemical – recording a change of the electric potential; detector of dispersed light – measuring the intensity of dispersion of a laser beam by molecules of the substance being separated; mass detectors – analysing compounds following their ionisation [1]. Apart from those mentioned here, which are the most popular, other techniques of detection are also applied, with different selectivity and using different properties of the analyte and with different degrees of sample degradation. If liquid chromatography is used to obtain mixture components with a view to further analysis, a method of detection must be

used which does not change the structure or properties of the compounds under analysis. The most popular one in such cases is a UV-Vis detector. Spots of substances being separated by paper or thin-layer chromatography are observed under visual or UV light, in their natural form or after transformation into a coloured compound. Both TLC and column chromatography are used in analysis of antioxidant compounds. In TLC, substances previously separated on the plate affect the intensity of colour of the radical placed on it. In liquid chromatography, tests of antioxidant activity of different components can be performed after they are separated in a pure state, by performing post-column off-line reactions or during the chromatographic separation on-line.

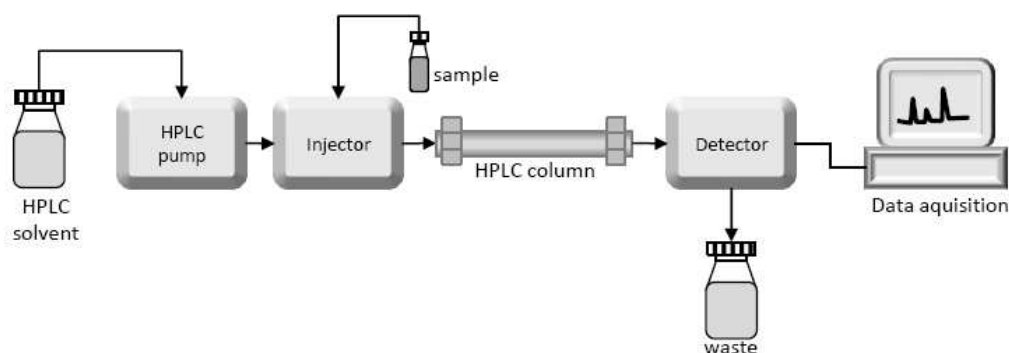

Figure 2. Schematic diagram of the High Performance Liquid Chromatography (HPLC) system

3. In vitro analysis of biological activity of substances.

In search of bioactive substances, researchers have directed their interest towards substances found in plants. Parts of plants which have been used in natural medicine have proved to be a rich source of bioactive compounds; however, to make use of them, they have to be isolated and their properties determined. Using selective techniques of extraction has resulted in obtaining concentrated preparations of bioactive substances. To achieve comprehensive knowledge of their properties, it was necessary to develop methods of isolation of individual components and testing these methods. This could be done with chromatographic techniques. Isolated compounds were tested in order to show which of them (and to what extent) are responsible for bioactivity of plant preparations from which they were obtained. Due to the fact that many of the substances have the opposite effect, it is frequently impossible to use extracts without isolating individual compounds.

In vitro tests, used in evaluation of antioxidant properties make use of the ability of antioxidants to quench free radicals. Based on this mechanism, the methods are divided into two groups: SET – single electron transfer, and HAT – hydrogen atom transfer. Reactions with antioxidants in assays with the DPPH radical, ABTS and the Folin-Ciocalteu reagent both operate according to the SET and HAT mechanism. Due to the kinetics of the reaction, they are included in the

group of SET assays. The HAT mechanism is of lesser importance in those assays [2]. SET assays include: DPPH, TEAC, FRAP, CUPRAC, DMPD, Folin-Ciocalteu; HAT assays include: ORAC, TRAP, CBA, β -carotene – linoleic model system. Those classified as “other” in literature include: cellular antioxidant activity (CAA), chemiluminescence, electrochemiluminescence, Total Oxyradical Scavenging Capacity Assay (TOSCA) and others [3].

3.1. Single Electron Transfer (SET) methods

3.1.1. 2,2-diphenyl-1-picrylhydrazyl (DPPH[•]) assay

Analysis of antioxidant properties relative to the DPPH[•] radical involves observation of colour disappearance in the radical solution in the presence of the solution under analysis which contains antioxidants. A solution of extract under analysis is introduced to the environment containing the DPPH[•] radical at a specific concentration. A methanol solution of the DPPH[•] radical is purple, while a reaction with antioxidants turns its colour into yellow. Colorimetric comparison of the absorbance of the radical solution and a solution containing an analysed sample enables one to make calculations and to express activity as the percent of inhibition (IP) or the number of moles of a radical that can be neutralised by a specific amount of the analysed substance (mmol/g). In another approach, a range of assays are conducted with different concentrations of the analysed substance to determine its amount which inactivates half of the radical in the test solution (EC₅₀). The duration of such a test depends on the reaction rate and observations are carried out until the absorbance of the test solution does not change [4]. If the solution contains substances whose absorbance disturbs the measurement, the concentration of DPPH[•] radical is measured directly with the use of electron paramagnetic resonance (EPR) spectroscopy.

The disadvantage of the method is the fact that there are numerous modifications in the literature. These include using radical solutions at different concentrations, different reaction times and sometimes even a different reaction environment. The effect of exposure to light, the presence of oxygen, pH and the type of solution on the stability of the DPPH[•] radical have been studied by Ozcelik and co-workers [5]. The study methods developed so far employ radical concentrations ranging from 6×10^{-5} to 2.0×10^{-4} mol/dm³ [6, 7, 8, 9, 10]. Depending on the method, absorbance of the reaction mixture is measured at the wavelength ranging from 515 nm to 550 [11, 12] after a specified reaction time, e.g. 5 min [13], 10 min [14], 16 min. [9], 20 min [7] 30 min [15], 60 min [16]. As Sánchez-Moreno and coworkers [17] found in their study, the time after which the absorbance of the analysed solution takes place depends on various factors, e.g. on the antioxidant concentration. For individual standards, they determined the time needed to reach the plateau at an antioxidant concentration of EC₅₀, i.e. such that is necessary to achieve 50% inactivation of the DPPH[•] radical. In order to make the results comparable, researchers frequently express them as Trolox equivalent [18]. The application of the assay is limited by the fact that the DPPH[•] radical is non-polar and as such, it is soluble in organic solvents. Noipa and co-workers [19] proposed to modify the method by using a cationic surfactant, which enabled analysis of the antioxidant activity of hydrophilic antioxidants contained in water extracts in the micelles formed in a solution.

3.1.2. Trolox Equivalent Antioxidant Capacity (TEAC) assay

An assay employing the ABTS^{•+} cation-radical was proposed by Miller and co-workers [20]. It is based on a colour reaction, in which the stable cation-radical ABTS^{•+} is formed from 2,2'-azinobis-(3-ethyl-benzothiazoline-6-sulfonic) acid (ABTS) with metmyoglobin and hydrogen peroxide. The reaction runs in phosphate-buffered saline, pH 7.4 (PBS). In a modification of the method proposed by Ozgen and co-workers [21], pH is equal to 4.5, which is to make it closer to that of the materials under analysis. A solution of the prepared radical turns blue-green, with the absorption spectrum within the range from approx 490 to 900 nm. When the antioxidants contained in the solution quench the ABTS^{•+} cation-radical, the solution absorbance decreases, which is observed by colorimetry after 6 minutes of the reaction at the temperature of 30°C and the wavelength of 734 nm. In the method modification proposed by Re and co-workers [22], the ABTS^{•+} radical is generated in the reaction of 2,2'-azinobis-(3-ethyl-benzothiazoline-6-sulfonic acid) diammonium salt and potassium persulfate in dark at room temperature for 12-16 hours. The analysis results are expressed as an equivalent of the reference substance, e.g. vitamin C, gallic acid, and, most frequently, Trolox. Trolox, which is water-soluble vitamin E analogue, is used to plot the standard curve. Due to this, it is possible to express the strength of antioxidants under analysis in a unified scale TEAC and to compare the results achieved by different researchers.

3.1.3. Ferric Ion Reducing Antioxidant Power (FRAP) assay

Analysis of antioxidant activity by performing a FRAP assay was proposed by Benzie and Strain [23]. It involves colorimetric determination of the reaction mixture in which the oxidants contained in the sample reduce Fe³⁺ ions to Fe²⁺. At low pH, Fe(III)-TPTZ (ferric-tripyridyltriazine) complex is reduced to the ferrous (Fe²⁺) form and intense blue colour at 593 nm can be observed. The FRAP reagent is prepared by mixing 2.5 ml of TPTZ (2,4,6-tris (1-pyridyl)-5-triazine) solution (10 mM in 40mM HCl), 25 ml acetate buffer, pH 3.6, and 2.5 ml FeCl₃•H₂O (20 mM). The colour of Fe(II)(TPTZ)₂ which appears in the solution is measured colorimetrically after incubation at 37°C. The measurement results are compared to those of a blank sample, which contains deionised water instead of the analysed sample. The duration of the assay differs from one study to another: 4 min [23, 24], 10 min [25] to 15 min [26]. The analysis results are converted and expressed with reference to a standard substance, which can be ascorbic acid [26], FeSO₄ [23, 25], Trolox [27,18].

3.1.4. CUPric Reducing Antioxidant Capacity (CUPRAC) assay

The CUPRAC assay, developed by Turkish researchers from Istanbul University [28], has undergone many modifications by which it has been adapted to wider applications [29, 30]. The mechanism of monitoring the antioxidant activity of the sample has remained unchanged. The assay is based on a coloured reaction during which copper ions in the CUPRAC reagent, Cu(II)-neocuproine (2,9-dimethyl-1,10-phenanthroline (Nc)), are reduced by antioxidants contained in the analysed sample. Chelates Cu(I)-Nc formed during the reaction have the maximum light absorption at the wavelength of 450 nm. The reaction runs at pH 7, which – as

the authors of the method have pointed out – is closer to the natural physiological environment, unlike in the FRAP assay (pH 3.6) and the Folin-Ciocalteu assay (pH 10) [29, 30]. Those same authors have pointed out the low cost of the method, its simplicity, response to thiol groups of antioxidants and, importantly, its flexibility, which enables using it – by changing a solvent – to examine both lipophilic and hydrophilic antioxidants. The reaction of Cu(II)-Nc with an antioxidant runs vigorously at 37°C, but certain compounds, such as naringine, require previous acidic hydrolysis.

3.1.5. DMPD (*N,N*-dimethyl-*p*-phenylenediamine) radical cation decolorization assay

A method of analysing antioxidant activity with respect to the DMPD^{•+} cation-radical (*N,N*-dimethyl-*p*-phenylenediamine cation radical) has been proposed by Fogliano and co-workers [31]. The determination principle involves colorimetric observation of the disappearance of the cation-radical colour at the absorbed light wavelength of 505 nm after a reaction time of 10 min. Coloured cation-radical DMPD^{•+} in the assay is obtained by reaction of DMPD with iron chloride in an acetate buffer at pH 5.25. The decrease in absorbance of the reaction mixture caused by antioxidants is compared to the calibration curve, prepared with a series of dilutions of Trolox [32].

Asghar and Khan [33] modified the method by adding K₂S₂O₈ (potassium persulfate) in an acetate buffer at pH 5.6 as the initiator of DMPD^{•+}. They abandoned ferric chloride, due to the presence of metal ions in the analysed material which could – as a result of the Fenton Reaction – induce formation of hydroxyl radicals, which affects the antioxidant activity which is being determined. They also noted that the DMPD^{•+} radical obtained in the reaction with K₂S₂O₈ is more stable than that obtained with FeCl₃ as iron ions are susceptible to oxidation by atmospheric oxygen.

The improved DPMD^{•+} decolorization assay is suitable for water-soluble as well as lipid-soluble antioxidants [33]. A stock solution of DMPD cation radical is diluted to $A_{517.5\text{nm}}=0.7\pm 0.8$ and after equilibration at 25°C stabilized with ethanol or an acetate buffer (pH 5.6). The experiment is conducted at 30°C and the absorbance of the reaction mixture is read out after 6 minutes. The measurement values obtained by the method with the cation radical DMPD are comparable with those obtained in the ABTS assay. As the cost of the DPMD is several times lower, it could be successfully used as an alternative for the ABTS assay [33].

3.1.6. Folin-Ciocalteu assay

The Folin-Ciocalteu reagent (FCR) is a complex formed in a reaction between sodium tungstate and sodium molybdenate in hydrochloric acid and phosphoric acid, which turns yellow after lithium sulphate is added. The reagent reacts in an alkaline environment with reducing compounds. Such a reaction gives a blue chromophore which is observed by colorimetry. The Folin-Ciocalteu method is highly sensitive – both to phenolic and non-phenolic compounds, e.g. proteins, vitamin C, vitamin B₁, folic acid, Cu(I). The method is applied most frequently to determine the total content of phenolic compounds [34, 35]. If that is the case, a sample for determination should be prepared in a proper manner to minimise the effect of non-phenolic

compounds on the assay results. One such method is to remove the solvent from the sample and to dissolve phenolic compounds in alcohol, which eliminates the compounds insoluble in that environment or ones which become denatured.

Performing the assay is reduced to putting an alcoholic solution of the analysed sample, Folin-Ciocalteu reagent and solution of sodium carbonate into a reaction tube, which brings the pH of the reaction environment to approx. 10. According to various literature reports, the reaction runs in the darkness for 10 to 120 minutes. After that time, the blue colour of the solution is observed colorimetrically at 725 nm – 760 nm [34, 35, 36, 37, 38]. The results are expressed based on calibration curves prepared for catechol and gallic acid.

3.2. Hydrogen Atom Transfer (HAT) methods

3.2.1. Total Radical Trapping Antioxidant Parameter (TRAP) assay

This method is based on the measurement of the fluorescence of a molecular sample. Canadian researchers proposed this method to determine total peroxy radical-trapping antioxidant capability of plasma [39]. They used a water-soluble azo compound, such as AAPH [2,2'-azobis-(2-amidinopropane)]. They measured the induction time electrochemically by measuring the time in which the antioxidants contained in the analysed sample prevent the capture of oxygen atoms. Four years later, DeLange and Glazer [40] proposed R-phycoerythrin in an induction measurement as a fluorescence indicator. They observed the time in which antioxidants in the sample protect R-phycoerythrin from oxidation and compared it with the time by which Trolox, added at a known amount, prevented a decrease in fluorescence. The reaction kinetics curve was monitored at the excitation wavelength of 495 and emission wavelength of 575, and antioxidant properties were expressed as Trolox equivalent. However, the method is time-consuming and rather complicated, which makes it susceptible to considerable errors, especially in inter-laboratory studies. Another modification of the method was developed by Valkonen and Kuusi [41], who used dichlorofluorescein diacetate (DCFH-DA) as an indicator of oxidation progress. DCFH-DA is hydrolysed in the presence of AAPH to highly fluorescent dichlorofluoresceine (DCF). An increase in fluorescence is a sign that the antioxidant activity of the analysed sample is exhausted.

3.2.2. Oxygen Radical Absorbance Capacity (ORAC) assay

The ORAC method was first proposed by Cao and co-workers in 1993. Like in the TRAP method, they used a fluorescent indicator. Determination of antioxidant activity by this method is based on measurement of decreasing fluorescence of the indicator caused by the radicals generated in the system. The reaction mixture in their proposal consisted of a fluorescent indicator β -phycoerythrin (β -PE), 2,2'-azobis(2-amidinopropane) dihydrochloride (AAPH) as a peroxy radical generator and the analysed sample [42]. Attributing the low purity of β -phycoerythrin (approx. 30%) to the low reproducibility of fluorescence and the occurrence of different forms of phycoerythrin, Ou and co-workers [43] modified the method by replacing the indicator with fluorescein (3',6'-dihydroxyspiro[isobenzofuran-1[3H],9'[9H]-xanthen]-3-one).

The reaction of antioxidants in a sample with the radicals generated by AAPH and fluorescein is conducted in a phosphate buffer at pH 7.4 and at the temperature of 37°C. As the reaction progresses, antioxidants in the analysed sample react with the radicals. With an excess of radicals, the ability of antioxidants to reduce them becomes exhausted and radicals react with fluorescein, oxidising it to a non-fluorescing form. Observation of the fluorescence of the reaction mixture is conducted at the excitation wavelength of 485 nm and emission wavelength of 525 nm. Measurements are conducted every 60-90 seconds until the resulting curve reaches a plateau.

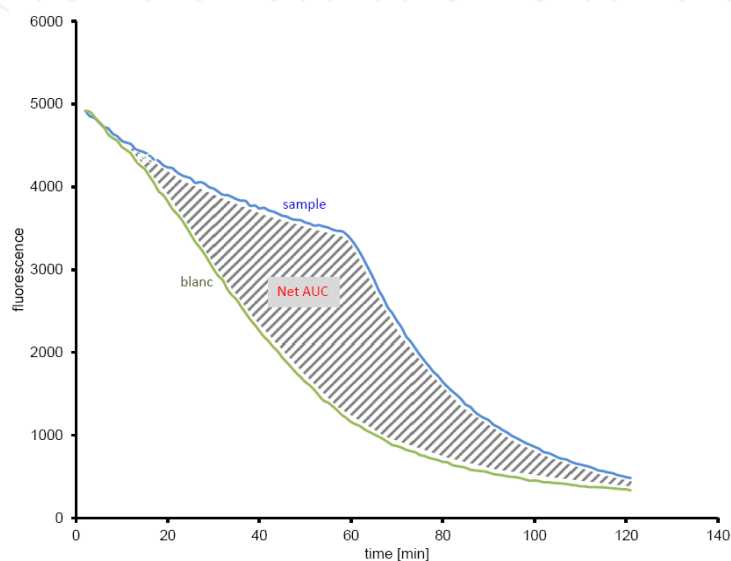

Figure 3. ORAC antioxidant activity determination of *Echium vulgare* defatted seeds methanolic extract expressed as net area under the curve (net AUC)

Surface area under the curve (AUC) was calculated by Ou and co-workers [43] from the following formula:

$$AUC = 1 + f_1/f_0 + f_2/f_0 + f_3/f_0 + f_4/f_0 + \dots + f_{34}/f_0 + f_{35}/f_0$$

where f_0 denotes fluorescence read out at the beginning of the assay and f_i denoted the value of fluorescence read after the time i .

The area under curve for the sample (AUC_{sample}), reduced by the area under curve plotted for the blank sample (AUC_{blanc}) is referred to as “net AUC”. Moreover, the net AUC is calculated for a series of dilutions of Trolox and a calibration curve is plotted, showing the relationship between net AUC and the concentration of Trolox. The results of the assay which refer the net AUC of the sample to the calibration curve are expressed as Trolox equivalent.

3.2.3. β -carotene bleaching test

Determination of the antioxidant activity in the system comprising β -carotene and linoleic acid is based on competitive oxidation of β -carotene during heat-induced auto-oxidation of linoleic

acid. In the method proposed by Miller [44], a decrease in the absorbance of aqueous emulsion of “ β -carotene – linoleic acid – analysed sample” depends on the antioxidant activity of the sample components. The antioxidant under study reacts with the radicals generated by linoleic acid in an incubated sample. As the ability of the analyte to scavenge radicals decreases, the oxidative effect on β -carotene increases. Measurement results of absorbance at 470 nm are read out every 15 minutes until the plateau is reached. The oxidative strength of the analyte is presented as the amount of β -carotene which was protected against oxidation.

3.2.4. Crocin Bleaching Assay (CBA)

Crocin is one of carotenoids present in saffron. It is present there as several isomers, differing by biological activity. The method of determination of antioxidant activity using crocin as an indicator was proposed in 1984 by Bors and co-workers [45]. In order to determine the antioxidant activity of the components of an analysed sample, it is put into a reaction tube together with solution of crocin diluted with phosphate buffer at pH 7.4. Thus obtained, the mixture is treated with radicals generated by solution of AAPH. The reaction runs at the temperature of 40°C. Decrease in the absorbance of the solution is measured colorimetrically at the wavelength of 443 nm and recorded for 10 minutes relative to the blank sample. The method has been modified many times [46, 47, 48]. Considering the problem of the unrepeatability of the composition of the saffron dye extract and, consequently, the differences in biological activity of the mixture of crocin isomers, Bathaie and co-workers [48] used α -crocin in their modification of the method. The results are expressed as “percent of inhibition of crocin degradation” (% Inh) and refer to the calibration curve prepared with Trolox and expressed as its equivalent (% Inh_{Trolox}).

3.3. Other methods

3.3.1. Cellular Antioxidant Activity (CAA) assay

A novel method of determination of antioxidant activity was proposed in 2007 by Wolfe and Liu of Cornell University [49]. They devised a method which is based on reactions running inside cells. According to them, the method better reflects reality than in-vitro methods due to the intake, metabolism and distribution of antioxidants in cells and, consequently, in a live organism. In a CAA assay, a solution of DCFH-DA (2',7'-Dichlorofluorescein diacetate) and a solution of the substances under analysis in PBS (phosphate buffered saline) at pH 7.4 is added to human hepatocarcinoma (HepG2) cells. Cells are incubated at 37°C and, during the incubation, DCFH-DA and components of the sample diffuse through the cell membrane into the cell. After that, the unabsorbed remainder is washed out with PBS and a solution of AAPH is added which – after its infiltration into a cell – generates free radicals oxidising DCFH-DA to DCF. Antioxidants quench the radicals, which reduces the amount of DCF, whose fluorescence is measured at 485 nm (ex.) and 520 nm (em.) during the analysis. The area under the fluorescence curve can be compared to the calibration curve prepared for a standard antioxidant, e.g. Trolox, and expressed as its equivalent. There are also modifications of the method, in which blood erythrocytes are used instead of HepG2 cells.

3.3.2. Total Oxyradical Scavenging Capacity (TOSCA) assay

Total Oxyradical Scavenging Capacity assay was proposed by Winston and co-workers as a rapid gas chromatographic method. They used this assay as a method of quantifiable measurement of the ability of sample antioxidants to quench free radicals [3]. The assay is based on the reaction between free radicals (peroxyl, hydroxyl, alkoxy) and α -keto- γ -methiolbutyric acid (KMBA). The reaction yields ethylene, which can be simply analysed by gas chromatography. The assay involves incubation of solutions of AAPH, KMBA and the analysed sample at 39°C, with resulting ethylene production. Its content is determined every 12 minutes for the 96–120 minute period of the assay. The values obtained in the measurement form the basis for plotting the curve illustrating the changes in ethylene content. Quantitative determination of TOSC is possible only by comparison of the area under the curve for the analysed sample (J_{SA}) and the control sample (J_{CA}). The value of TOSC was calculated by Winston and co-workers as the difference between 100 and the ratio of the area for the analysed sample and the control sample, multiplied by 100.

$$TOSC = 100 - 100 * \left(\frac{J_{SA}}{J_{CA}} \right)$$

When the radical inhibition reaches its theoretical maximum, ethylene is not produced and the value of TOSC is equal to 100 [3].

4. On-line liquid chromatography in bioactivity determination of compounds

The methods of determination of antioxidant activity are popular, which does not mean that they are only used in scientific research. A number of modifications of those methods along with methods which are not presented here are still used in analytical procedures applied in examination of bioactive substances. Owing to constantly broadening knowledge on the mechanism of oxidation and action of antioxidants, the choice and development of analytical methods is also changing. Increasing awareness of biological activity and the availability of analytical methods has changed the way substances are analysed. Regarding the different transport mechanisms of substances in organisms, observations have been conducted with different test cells. An analysis of different substances in mixtures has revealed differences in their biological activity. Due to such differences within a sample, it may contain both strong antioxidants and biologically inactive compounds as well as pro-oxidants. Their separation may obtain individual substances, or their mixtures, with beneficial biological properties. In search of rich sources of bioactive substances, screening studies are conducted in which isolated components of mixtures are analysed for their activity, e.g. as antioxidants. Time and money which must be spent on such analyses, as well as new testing capabilities, combined with chromatographic methods have made looking for such sources much cheaper and easier. Examples of using different chromatographic methods to inhibit or promote oxidation reactions are presented below.

4.1. TLC-methods for antioxidant activity analysis

Analysis of the biological activity of extracts by the methods presented above provides a researcher with a pooled result of the activities of all the components of a mixture. When analysing extracts of evening-primrose and starflower, Wettasinghe and Shahidi [50] made use of the experience gathered by Amarowicz and co-workers in fractionation of plant extracts [51, 52, 53] to achieve more precise characteristics of components of the extracts under analysis. They separated extracts by column chromatography with Sephadex LH20 column packing. As a result, they obtained six fractions, which they further analysed to determine their biological activity [50].

Separation of analyte fractions by column chromatography requires time, labour and money and the results show only properties of the properties of compounds in individual fractions. Using thin-layer chromatography in analysis of antioxidant activity of mixture components made it unnecessary to isolate them prior to analysis. Researchers from Kansas State University made use of the experience gathered by Marco [54] and Taga and co-workers [55] and proposed a method of determination of antioxidant activity of individual components of mixtures using the β -carotene bleaching assay for substances previously separated by TLC. They sprinkled β -carotene solution with linoleic acid on substances separated on a plate. They exposed the prepared plates to light and observed the disappearance of the orange colour of β -carotene. Spots with antioxidants were visible as ones with more intense colour because of their protective effect on β -carotene [56].



Figure 4. Compounds resolved on the TLC plate after spraying with DPPH methanolic solution.

Glavind and Holmer proposed a method of determination of antioxidants by TLC using the DPPH \cdot radical. They sprinkled a plate with separated substances with methanol solution of the radical and observed discoloration where substances able to quench radicals were present [57]. The TLC-DPPH assay allows a researcher to access the analysed substances and to assess the biological activity of individual compounds. Another advantage of the method is the possibili-

ty of conducting screening analyses in which many extracts can be analysed. This enables effective and cheap searching for bioactive substances in unknown samples [58, 59, 60, 61].

4.2. The use of high performance liquid chromatography as a tool for bioactivity analysis

When seeking a tool which could be used to determine the biological activity of mixture components in a more precise way, researchers directed their attention towards high-performance liquid chromatography (HPLC). Its advantage over TLC is its higher resolution, which helps to avoid false results caused by the co-elution of different compounds.

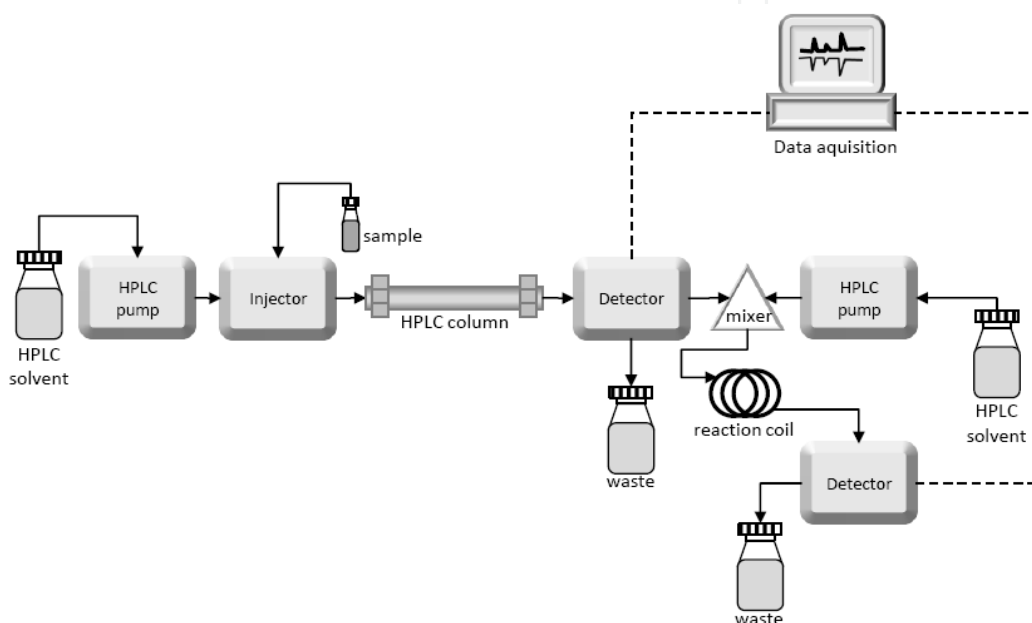

Figure 5. Instrumental setup for on-line HPLC radical scavenging assay

4.2.1. HPLC-DPPH[•] stable radicals decolorization

Initially, the use of HPLC in analysis of antioxidant properties with the DPPH[•] radical was restricted to chromatographic analysis of the radical content in solution. An assay was performed in which a solution of the radical was treated with the extract under analysis. The reaction ran in a reaction tube and the remainder of the radical after the reaction was analysed chromatographically. A comparison of the radical content in the blank sample and in the extract sample showed the amount of radical that was quenched by antioxidants in the analysed sample [62, 63]. However, the method did not provide more information than the colorimetric method. Much better results are obtained in a post-column on-line reaction in which substances separated on a chromatographic column react with a radical in a reaction coil.

A detector records a signal at 515 or 517 nm [64, 65]. Depending on the antioxidant activity of the separated substances, greater or smaller signal fading can be observed, resulting in a negative peak. The surface area of the peak, proportional to the antioxidant activity (compared

to the standard curve plotted for Trolox) is the basis for expressing the result as its equivalent. An apparatus which can be used to conduct such an analysis should – like the basic HPLC set – consist of the main pump (feeding mobile phase to the system), an injecting device (injecting the sample), a column (which may be placed in a thermostat), a detector and a recording device. However, additional equipment must be used apart from the HPLC set. A solution of the DPPH• is fed through an additional pump and, together with eluate, leaves the HPLC system to the mixer. Mixed substances are transferred to the reaction coil. A reaction coil, which is a capillary tube with a length ranging from 0.2 to 15 m, is where a reaction takes place between the mixture components and the DPPH reagent.

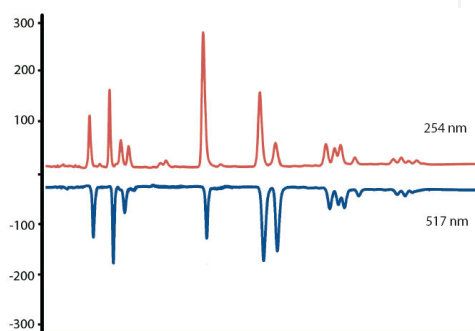

Figure 6. UV and DPPH radical quenching chromatogram of a plant methanolic extract.

Bartasiute and co-workers [66] analysed the method with capillaries of different lengths. The shortest capillary used in their experiment (0.2 m) ensured sufficient reaction time. However, specific properties of analysed mixtures should be taken into account, whose components may react differently. The last element is another detector which records the characteristic signal of the DPPH• solution [65, 66, 67, 68]. Fading of a radical signal after reaction with an antioxidant (visible as a negative peak) is proportional to its oxidative force. Comparison of the surface area of the peak with the calibration curve prepared for Trolox shows the activities of the substances as equivalents of the antioxidant.

4.2.2. On-line HPLC-ABTS^{•+} stable radical decolorization

Using the ABTS^{•+} cation radical in the analysis of activity of mixture components in conjunction with HPLC was proposed in 2001 [69]. That method is similar to the HPLC-DPPH• assay described above, but its sensitivity is higher. Components separated on an analytical column are transferred with a solution of the ABTS^{•+} cation radical to the reaction coil. A capillary with a length ranging from 1.5 to 15 metres is placed where the flow-through reaction of the radical quenching by the oxidants present in the sample takes place. The capillary length is selected depending on the expected reaction time. The signal characteristics of the ABTS^{•+} radical solution are recorded at 734 nm [69, 70] and in subsequent modifications – at 720 nm and 747 nm [16, 71, 72]. The antioxidant activity of individual compounds is determined based on the size of negative peaks which show the compound's ability to inactivate the radical. Comparison of the surface area of a negative peak caused by the presence of the analysed compound

with the curve prepared for Trolox enables the activity of compounds to be expressed as the Trolox equivalent.

4.2.3. *On-line HPLC-CUPRAC assay*

An on-line HPLC-CUPRAC assay has been proposed by Çelik and co-workers. They used a chromatographic set with configuration used in on-line analysis of antioxidant properties with the DPPH• and ABTS•+ radicals. Unlike the methods with the DPPH• and ABTS•+ radicals, the assay is based on measurement of the growth of the solution colour intensity [73]. As in the off-line method, the Cu(II)-Nc reagent reacts with an antioxidant and is reduced to a yellow complex Cu(I)-Nc. The solution containing the complex has the absorbance with the maximum at 450 nm. The compounds separated chromatographically in the developed on-line method are mixed with the Cu(II)-Nc reagent in a mixer and are subsequently transferred to the reaction coil where a oxidation-reduction reaction takes place during its flow through the capillary. The antioxidant activity of individual compounds is observed as an increase in the signal on the detector at 450 nm. When a calibration curve is plotted with data obtained for Trolox, it is possible to express the compound's activity as an equivalent of Trolox activity [73].

4.2.4. *On-line HPLC Crocin Bleaching Assay (HPLC-CBA)*

The Crocin Bleaching Assay (CBA) in an off-line colorimetric version provided the base for developing the On-line HPLC-Crocin Bleaching Assay [74]. When a high-resolution method of compound separation is used, CBA can be used to determine the activities of each mixture component. The results are not affected by other mixture components, which improves the usability of the method for an objective assessment of bioactive components of mixtures. Like the off-line method described earlier, the authors of this method proposed crocin as the oxidation indicator and the AAPH reagent as the source of the radical. Antioxidants in a sample prevent oxidation of crocin by inactivating radicals generated by the AAPH reagent, as was the case in the colorimetric method. The signal recorded by the detector for 440 nm shows the antioxidant activity of each compound as chromatographic peaks with a surface area proportional to their activity. The mixture of crocin and the AAPH reagent was kept at 0°C before being transferred to the system. The reaction mixture was combined on-line with eluate from the chromatographic column and the reaction between compounds ran during their flow through the reaction coil at 90°C. The reaction parameters have a great effect on the interference caused by the detector; hence, the authors optimised the method, showing that the interference is affected by: instability of the reaction temperature, change of the AAPH:crocin ratio, the presence of air or nitrogen bubbles in the reaction coil and changes in the mobile phase composition [74]. Like other methods, it seems justified to express the results in a universal unit, i.e. the equivalent of a standard antioxidant, e.g. Trolox.

4.2.5. *On-line chemiluminescence detection (HPLC-CL)*

A sensitive on-line chemiluminescence method, "on-line HPLC-CL", was developed by Toyo'oka and co-workers [75]. This method helps to determine with high sensitivity the antioxidant activity of the separated compounds relative to H₂O₂ and O₂•-. In order to deter-

mine the activity of compounds relative to H_2O_2 , a solution of luminol and H_2O_2 must be prepared. The activity of the analysed components relative to $\text{O}_2^{\cdot-}$ is measured in the system of reagents containing a mixture of luminol and hypoxanthine as well as a mixture of xanthine oxidase and catalase. The solutions, fed with two pumps, are mixed in a mixer before being joined with a stream of chromatographically-separated components which leave the column. Combining the streams of reagents and the analyte starts the reaction of radical quenching of the analysed sample by antioxidants. A decrease in the amount of radicals results in a decrease in the luminol luminescence intensity recorded by the detector. The compounds able to quench the radicals cause the signal to deviate from the base line, which is observed as negative peaks. The surface area of the peaks is proportional to the antioxidant activity of the analysed compounds. As is shown in the description, the method requires proper apparatus. The HPLC set, necessary to separate the mixture components under analysis has to be fitted out with two separate pumps and a mixer. The stream of eluate from the analytic column and the reagents are joined in a mixing module, after which the mixture is transferred to the reaction coil. When it flows through the reaction coil, radical capture reaction takes place and the other radicals react with luminol. The radiation generated in this way is recorded by a photomultiplier. A negative chromatogram generated in this manner is used as the basis for assessment of antioxidant activity of the separated compounds. Like the methods described above, the assessment is based on a comparison of surface area of peaks with the calibration curve prepared for a standard antioxidant, e.g. Trolox.

5. Conclusion

People have made use of the properties of different compounds without realising their existence for a long time. Since science found ways to determine the nature of the effects exerted by bioactive compounds (e.g. medicinal plants) analytical methods have been perfected to enable more detailed analysis of the material. Analyses have focused on determination of the intensity of biological activity and on identification of the components responsible for the activity. Many materials have been analysed in search of bio-components. Mastering chromatographic methods has provided the possibility of high-resolution analysis of compounds, including their biological activity. The analytical methods which have been characterised here are the result of several dozen years of research into improving analytical methods in the search for biologically active compounds. The proposed classification is based on the mechanism of reaction observed in assays. The methods make use of reactions induced by the presence of radicals generated as initiators of oxidation reactions prevented by analysed bioactive compounds. It is not the only possible approach to looking for and analysing bioactive compounds. Various methods of analysing antioxidant activity which have not been mentioned above have been applied on a marginal scale due to their drawbacks. Apart from that, there are methods of analysing biological activity which analyse substances capable of inhibition of/affinity to certain enzymes, e.g. acetylcholinesterase, phosphodiesterase, glutathione-S-transferase (EAD – Enzyme Activity/Affinity Detection), affinity of bioactive substances receptors, e.g. estrogen receptor (RAD – Receptor Affinity Detection) [76, 77, 78, 79, 80,

81, 82]. Conjunction of the chromatographic methods of component separation with methods of analysis of biological properties provides great opportunities in their analysis. This has made the search for bioactive substances easier and will aid the future development of new research methods.

Acknowledgements

This study was supported by the Grant N N312 466340 from the National Science Centre, Poland.

Author details

Sylwester Czaplicki

Chair of Food Plant Chemistry and Processing, Faculty of Food Sciences, University of Warmia and Mazury in Olsztyn, Olsztyn, Poland

References

- [1] Witkiewicz Z, Kałużna-Czaplińska J. Basics of chromatography and electromigration techniques. Warsaw: WNT; 2012.
- [2] Prior RL, Wu X, Schaich K. Standardized methods for the determination of antioxidant capacity and phenolics in foods and dietary supplements. *Journal of Agricultural and Food Chemistry*. 2005; 53(10) 4290–4302.
- [3] Winston GW, Regoli F, Dugas AJ Jr, Fong JH, Blanchard KA. A rapid gas chromatographic assay for determining oxyradical scavenging capacity of antioxidants and biological fluids. *Free Radic Biol Med*. 1998; 24(3) 480-493.
- [4] Brand-Williams W, Cuvelier ME, Berset C. Use of a free radical method to evaluate antioxidant activity. *Food Science and Technology*. 1995; 28 25-30.
- [5] Ozcelik B, Lee JH, Min DB. Effects of Light, Oxygen, and pH on the Absorbance of 2,2-Diphenyl-1-picrylhydrazyl. *Journal of Food Science*. 2003; 68(2) 487–490.
- [6] Bondet V, Brand-Williams W, Berset C. Kinetics and Mechanisms of Antioxidant Activity using the DPPH• Free Radical Method. *Food Science and Technology*. 1997; 30, 609–615.

- [7] Locatelli M, Gindro R, Travaglia F, Coisson J-D, Rinaldi M, Arlorio M. Study of the DPPH-scavenging activity: Development of a free software for the correct interpretation of data. *Food Chemistry*. 2009; 114 889–897.
- [8] Stankevičius, M.; Akuneca, I.; Jākobsone, I.; Maruška, A. Analysis of phenolic compounds and radical scavenging activities of spice plants extracts. *Food Chemistry and Technology*. 2010; 44(2) 85-91.
- [9] Moure A, Franco D, Sineiro J, Dominguez H, Nunez MJ, Lema JM. Antioxidant activity of extracts from *Gevuina avellana* and *Rosa rubiginosa* defatted seeds. *Food Research International*. 2001; 34(2/3) 103-109.
- [10] Hatano T, Kagawa H, Yasuhara T, Okuda T. Two new flavonoids and other constituents in licorice root: their relative astringency and radical scavenging effects. *Chemical & Pharmaceutical Bulletin*. 1988; 36(6) 2090-2097.
- [11] Müller L, Fröhlich K, Böhm V. Comparative antioxidant activities of carotenoids measured by ferric reducing antioxidant power (FRAP), ABTS bleaching assay (α TEAC), DPPH assay and peroxy radical scavenging assay. *Food Chemistry*. 2011; 129 139–148
- [12] Marxen K, Vanselow KH, Lippemeier S, Hintze R, Ruser A, Hansen U-P. Determination of DPPH Radical Oxidation Caused by Methanolic Extracts of Some Microalgal Species by Linear Regression Analysis of Spectrophotometric Measurements. *Sensors*. 2007; 7, 2080-2095.
- [13] Mandal P, Misra TK, Ghosal M. Free-radical scavenging activity and phytochemical analysis in the leaf and stem of *Drymaria diandra* Blume. *International Journal of Integrative Biology*. 2009; 7(2) 80-84.
- [14] Wojdyło A, Oszmiański J, Czemerys R. Antioxidant activity and phenolic compounds in 32 selected herbs. *Food Chemistry*. 2007; 105 940–949.
- [15] Wu JH, Huang CY, Tung YT, Chang ST. Online RP-HPLC-DPPH screening method for detection of radical-scavenging phytochemicals from flowers of *Acacia confusa*. *Journal of Agricultural and Food Chemistry*. 2008; 56(2) 328-332.
- [16] Gong Y, Liu X, He W-H, Xu H-G, Yuan F, Gao Y-X. Investigation into the antioxidant activity and chemical composition of alcoholic extracts from defatted marigold (*Tagetes erecta* L.) residue. *Fitoterapia* 2012; 83 481–489.
- [17] Sánchez-Moreno C, Larrauri JA, Saura-Calixto F. A Procedure to Measure the Antiradical Efficiency of Polyphenols. *Journal of the Science of Food and Agriculture*. 1998; 76 270-276.
- [18] Michel T, Destandau E, GLe Floch G, Lucchesi ME, Elfakir C. Antimicrobial, antioxidant and phytochemical investigations of sea buckthorn (*Hippophaë rhamnoides* L.) leaf, stem, root and seed. *Food Chemistry*. 2012; 131 754–760.

- [19] Noipa T, Srijaranai S, Tuntulani T, Ngeontae W. New approach for evaluation of the antioxidant capacity based on scavenging DPPH free radical in micelle systems. *Food Research International*. 2011; 44(3) 798–806.
- [20] Miller NJ, Rice-Evans C, Davies MJ, Gopinathan V, Milner A. A novel method for measuring antioxidant capacity and its application to monitoring the antioxidant status in premature neonates. *Clinical Science*. 1993; 84 407-412.
- [21] Ozgen M, Reese RN, Tulio AZ Jr, Scheerens JC, Miller AR. Modified 2,2-azino-bis-3-ethylbenzothiazoline-6-sulfonic acid (abts) method to measure antioxidant capacity of Selected small fruits and comparison to ferric reducing antioxidant power (FRAP) and 2,2'-diphenyl-1-picrylhydrazyl (DPPH) methods. *Journal of Agricultural and Food Chemistry*. 2006; 54(4) 1151-1157.
- [22] Re R, Pellegrini N, Proteggente A, Pannala A, Yang M, Rice-Evans C. Antioxidant activity applying an improved ABTS radical cation decolorization assay. *Free Radical Biology & Medicine*, 1999; 26(9/10) 1231–1237.
- [23] Benzie IFF, Strain JJ. The Ferric Reducing Ability of Plasma (FRAP) as a Measure of “Antioxidant Power”: The FRAP Assay. *Analytical Biochemistry*. 1996; 239 70–76.
- [24] Panda N, Kaur H, Mohanty TK. Reproductive performance of dairy buffaloes supplemented with varying levels of vitamin E. *Asian Australasian Journal of Animal Sciences*. 2006; 19(1) 19-25.
- [25] Oveisi MR, Sadeghi N, Jannat B, Hajimahmoodi M, Behfar A, Jannat F, Nasaba FM. Human Breast Milk Provides Better Antioxidant Capacity than Infant Formula. *Iranian Journal of Pharmaceutical Research*. 2010; 9(4) 445-449.
- [26] Valvi SR, Rathod VS, Yesane DP. Screening of three wild edible fruits for their antioxidant potential. *Current Botany*. 2011; 2(1) 48-52.
- [27] Thaipong K, Boonprakob U, Crosby K, Cisneros-Zevallos L, Byrne DH. Comparison of ABTS, DPPH, FRAP, and ORAC assays for estimating antioxidant activity from guava fruit extracts. *Journal of Food Composition and Analysis*. 2006; 19 669–675.
- [28] Apak R, Güçlü K, Özyürek M, Karademir SE. Novel Total Antioxidant Capacity Index for Dietary Polyphenols and Vitamins C and E, Using Their Cupric Ion Reducing Capability in the Presence of Neocuproine: CUPRAC Method. *Journal of Agricultural and Food Chemistry*. 2004; 52 (26) 7970–7981.
- [29] Çelik SE, Özyürek M, Güçlü K, Apak R. CUPRAC total antioxidant capacity assay of lipophilic antioxidants in combination with hydrophilic antioxidants using the macrocyclic oligosaccharide methyl b-cyclodextrin as the solubility enhancer. *Reactive & Functional Polymers*. 2007; 67 1548–1560.
- [30] Çelik SE, Özyürek M, Güçlü K, Apak R. Solvent effects on the antioxidant capacity of lipophilic and hydrophilic antioxidants measured by CUPRAC, ABTS/persulphate and FRAP methods. *Talanta* 2010; 81 1300–1309.

- [31] Fogliano V, Verde V, Randazzo G, Ritieni A. Method for measuring antioxidant activity and its application to monitoring the antioxidant capacity of wines. *Journal of Agricultural and Food Chemistry*. 1999; 47(3) 1035-40.
- [32] Busuricu F, Negranu-Pârjol T, Balaban DP, Popescu A, Anghel A. The evaluation of the wines antioxidant activity. *Innovative Romanian Food Biotechnology*. 2008; 2(2) 10-18.
- [33] Asghar MN, Khan IU, Arshad MN, Sherin L. Evaluation of antioxidant activity using an improved dmpd radical cation decolorization assay. *Acta Chimica Slovenica*. 2007; 54(2) 295-300.
- [34] Huang D, Ou B, Prior RL. The chemistry behind antioxidant capacity assays. *Journal of Agricultural and Food Chemistry*. 2005; 53(6) 1841-1856.
- [35] Agbor GA, Oben JE, Ngogang JY, Xinxing C, Vinson JA. Antioxidant Capacity of Some Herbs/Spices from Cameroon: A Comparative Study of Two Methods. *Journal of Agricultural and Food Chemistry*. 2005; 53(17) 6819-6824.
- [36] Krishnaiah D, Sarbatly R, Nithyanandam R. A review of the antioxidant potential of medicinal plant species. *Food and Bioproducts Processing*. 2011; 89 217-233.
- [37] Abe LT, Lajolo FM, Genovese MI. Comparison of phenol content and antioxidant capacity of nuts. *Ciência e Tecnologia de Alimentos* 2010; 30(1) 254-259.
- [38] Habib R, Rahman M, Mannan A, Zulfiker AH, Uddin ME, Sayeed MA. Evaluation of antioxidant, cytotoxic, antibacterial potential and phytochemical screening of chloroform extract of *Phyllanthus acidus*. *International Journal of Applied Biology and Pharmaceutical Technology*. 2011; 2(1) 420-427.
- [39] Wayner DD, Burton GW, Ingold KU, Locke S. Quantitative measurement of the total, peroxy radical-trapping antioxidant capability of human blood plasma by controlled peroxidation. The important contribution made by plasma proteins. *Federation of European Biochemical Societies Letters* 1985; 187(1) 33-37.
- [40] DeLange RJ, Glazer AN. Phycoerythrin fluorescence-based assay for peroxy radicals: a screen for biologically relevant protective agents. *Analytical Biochemistry*. 1989; 177(2) 300-306.
- [41] Valkonen M, Kuusi T. Spectrophotometric assay for total peroxy radical-trapping antioxidant potential in human serum. *Journal of Lipid Research*. 1997; 38(4) 823-33.
- [42] Cao G, Alessio HM, Cutler RG. Oxygen-radical absorbance capacity assay for antioxidants. *Free Radical Biology & Medicine*. 1993; 14(3) 303-11.
- [43] Ou B, Hampsch-Woodill M, Prior RL. Development and Validation of an Improved Oxygen Radical Absorbance Capacity Assay Using Fluorescein as the Fluorescent Probe. *Journal of Agricultural and Food Chemistry*. 2001; 49 4619-4626.

- [44] Miller HE. A simplified method for the evaluation of antioxidants, *Journal Of The American Oil Chemists' Society*. 1971; 48(2) 91.
- [45] Bors W, Michel C, Saran M. Inhibition of the bleaching of the carotenoid crocin a rapid test for quantifying antioxidant activity. *Biochimica et Biophysica Acta (BBA)/Lipids and Lipid Metabolism*. 1984; 796(3) 312-319.
- [46] Tubaro F, Micossi E, Ursini F. The antioxidant capacity of complex mixtures by kinetic analysis of crocin bleaching inhibition. *Journal of the American Oil Chemists' Society*. 1996; 73(2) 173-179.
- [47] Ordoudi SA, Tsimidou MZ. Crocin bleaching assay (CBA) in structure-radical scavenging activity studies of selected phenolic compounds. *Journal of Agricultural and Food Chemistry*. 2006; 54(25) 9347-9356.
- [48] Bathaie SZ, Kermani FMZ, Shams A. Crocin Bleaching Assay Using Purified Di-gentiobiosyl Crocin (α -crocin) from Iranian Saffron. *Iranian Journal of Basic Medical Sciences*. 2011; 14(5) 399-406.
- [49] Wolfe KL, Liu RH. Cellular Antioxidant Activity (CAA) Assay for Assessing Antioxidants, Foods, and Dietary Supplements. *Journal of Agricultural and Food Chemistry*. 2007; 55(22) 8896-8907.
- [50] Wettasinghe M, Shahidi F. Scavenging of reactive-oxygen species and DPPH free radicals by extracts of borage and evening primrose meals. *Food Chemistry*. 2000; 70 17-26.
- [51] Amarowicz R, Koslowska H, Shimoyamada M. Chromatographic analysis of rapeseed glucosides fractions. *Polish Journal of Food and Nutrition*. 1992; 1 89-93.
- [52] Amarowicz R, Wanasundara U, Wanasundara J, Shahidi F. Antioxidant activity of ethanolic extracts of faxseed in a β -carotene-linoleate model system. *Journal of Food Lipids*. 1993; 1 111-117.
- [53] Amarowicz R, Shahidi F. A rapid chromatographic method for separation of individual catechins from green tea. *Food Research International* 1996; 29 71-76.
- [54] Marco JG. A rapid method for evaluation of antioxidants. *Journal Of The American Oil Chemists' Society*. 1968; 45(9) 594-598.
- [55] Taga SM, Miller EE, Pratt DE. Chia Seeds as a Source of Natural Lipid Antioxidants. *Journal of the American Oil Chemists' Society*. 1984; 61(5) 928-931.
- [56] Mehta RL, Zayas JF, Yang S-S. Ajowan as a Source of Natural Lipid Antioxidant. *Journal of Agricultural and Food Chemistry*. 1994; 42(7) 1420-1422.
- [57] Glavind J, Holmer G. Thin-layer chromatographic determination of antioxidants by the stable free radical α , α' -diphenyl- β -picrylhydrazyl. *Journal of the American Oil Chemists' Society*. 1967; 44(9) 539 - 542.

- [58] Masoko P, Eloffa JN. Screening of Twenty-Four South African Combretum and Six Terminalia Species (Combretaceae) for Antioxidant Activities. *African Journal of Traditional, Complementary and Alternative medicines*. 2007; 4(2) 231–239.
- [59] Jothy SL, Zuraini Z, Sasidharan S. Phytochemicals screening, DPPH free radical scavenging and xanthine oxidase inhibitory activities of Cassia fistula seeds extract. *Journal of Medicinal Plants Research*. 2011; 5(10) 1941-1947.
- [60] Cieśła Ł, Kryszeń J, Stochmal A, Oleszek W, Waksmundzka-Hajnos M. Approach to develop a standardized TLC-DPPH• test for assessing free radical scavenging properties of selected phenolic compounds. *Journal of Pharmaceutical and Biomedical Analysis*. 2012; 70 126– 135.
- [61] Olech M, Komsta Ł, Nowak R, Cieśła Ł, Waksmundzka-Hajnos M. Investigation of antiradical activity of plant material by thin-layer chromatography with image processing. *Food Chemistry*. 2012; 132 549–553.
- [62] Yamaguchi T, Takamura H, Matoba T, Terao J. HPLC method for evaluation of the free radical-scavenging activity of foods by using 1,1-diphenyl-2-picrylhydrazyl. *Bio-science, Biotechnology, and Biochemistry*. 1998; 62(6) 1201-1204.
- [63] Bhandari P, Kumar N, Singh B, Ahuja PS. Online HPLC-DPPH method for antioxidant activity of *Picrorhiza kurroa* Royle ex Benth. and characterization of kutkoside by Ultra-Performance LC-electrospray ionization quadrupole time-of-flight mass spectrometry. *Indian Journal of Experimental Biology*. 2010; 48 323-328.
- [64] Bandoniene D, Murkovic M. On-Line HPLC-DPPH Screening Method for Evaluation of Radical Scavenging Phenols Extracted from Apples (*Malus domestica* L.). *Journal of Agricultural and Food Chemistry*. 2002; 50, 2482-2487.
- [65] Koleva II, Niederländer HA, van Been TA. An on-line HPLC method for detection of radical scavenging compounds in complex mixtures. *Analytical Chemistry*. 2000; 72(10) 2323-2328.
- [66] Bartasiute A, Westerink BHC, Verpoorte E, Niederländer HAG. Improving the in vivo predictability of an on-line HPLC stable free radical decoloration assay for antioxidant activity in methanol–buffer medium. *Free Radical Biology & Medicine*. 2007; 42 413–423.
- [67] Dapkevicius A, van Beek TA, Niederländer HAG. Evaluation and comparison of two improved techniques for the on-line detection of antioxidants in liquid chromatography eluates. *Journal of Chromatography A*. 2001; 912 73–82.
- [68] Zhang Q, van der Klift EJ, Janssen HG, van Beek TA. An on-line normal-phase high performance liquid chromatography method for the rapid detection of radical scavengers in non-polar food matrixes. *Journal of Chromatography A*. 2009; 1216 7268–7274.

- [69] Koleva II, Niederländer HA, van Been TA. Application of ABTS radical cation for selective on-line detection of radical scavengers in HPLC eluates. *Analytical Chemistry*. 2001; 73(14) 3373–3381.
- [70] Yildiz L, Başkan KS, Tütem E, Apak R. Combined HPLC-CUPRAC (cupric ion reducing antioxidant capacity) assay of parsley, celery leaves, and nettle. *Talanta*. 2008; 77(1) 304-313.
- [71] Stalmach A, Mullen W, Nagai C, Crozier A. On-line HPLC analysis of the antioxidant activity of phenolic compounds in brewed, paper-filtered coffee. *Brazilian Journal of Plant Physiology*. 2006; 18(1) 253-262.
- [72] Stewart AJ, Mullen W, Crozier A. On-line high-performance liquid chromatography analysis of the antioxidant activity of phenolic compounds in green and black tea. *Molecular Nutrition & Food Research*. 2005; 49(1) 52–60.
- [73] Çelik SE, Özyürek M, Güçlü K, Apak R. Determination of antioxidants by a novel on-line HPLC-cupric reducing antioxidant capacity (CUPRAC) assay with post-column detection. *Analytica Chimica Acta*. 2010; 674 79–88.
- [74] Bountagkidoua O, van der Klift EJC, Tsimidou MZ, Ordoudi SA, van Beek TA. An on-line high performance liquid chromatography-crocin bleaching assay for detection of antioxidants. *Journal of Chromatography A*. 2012; 1237 80– 85.
- [75] Toyo'oka T, Kashiwazaki T, Kato M. On-line screening methods for antioxidants scavenging superoxide anion radical and hydrogen peroxide by liquid chromatography with indirect chemiluminescence detection. *Talanta*. 2003; 60 467-475.
- [76] Ingkaninan K, de Best CM, van der Heijden R, Hofte AJ, Karabatak B, Irth H, Tjaden UR, van der Greef J, Verpoorte R. High-performance liquid chromatography with on-line coupled UV, mass spectrometric and biochemical detection for identification of acetylcholinesterase inhibitors from natural products. *Journal of Chromatography A*. 2000; 872(1-2) 61-73.
- [77] Andrisano V, Bartolini M, Gotti R, Cavrini V, Felix G. Determination of inhibitors' potency (IC_{50}) by a direct high-performance liquid chromatographic method on an immobilised acetylcholinesterase column. *Journal of Chromatography B*. 2001; 753 375–383.
- [78] Schobel U, Frenay M, van Elswijk DA, McAndrews JM, Long KR, Olson LM, Bobzin SC, Irth H. High resolution screening of plant natural product extracts for estrogen receptor alpha and beta binding activity using an online HPLC-MS biochemical detection system. *Journal of Biomolecular Screening*. 2001; 6(5) 291-303.
- [79] van Liempd SM, Kool J, Niessen WM, van Elswijk DE, Irth H, Vermeulen NP. On-line formation, separation, and estrogen receptor affinity screening of cytochrome P450-derived metabolites of selective estrogen receptor modulators. *Drug Metabolism and Disposition*. 2006;34(9) 1640-1649.

- [80] Alphonse MP, Saffar AS, Shan L, HayGlass KT, Simons FER, Gounni AF. Regulation of the High Affinity IgE Receptor (FceRI) in Human Neutrophils: Role of Seasonal Allergen Exposure and Th-2 Cytokines. *PLoS ONE*. 2008; 3(4) e1921. doi:10.1371/journal.pone.0001921.
- [81] Mroczek T. Highly efficient, selective and sensitive molecular screening of acetylcholinesterase inhibitors of natural origin by solid-phase extraction-liquid chromatography/electrospray ionisation-octopole-orthogonal acceleration time-of-flight-mass spectrometry and novel thin-layer chromatography-based bioautography. *Journal of Chromatography A*. 2009; 1216 2519–2528.
- [82] Shi S-Y, Zhou H-H, Zhang Y-P, Jiang X-Y, Chen X-Q, Huang K-L. Coupling HPLC to on-line, post-column (bio)chemical assays for high-resolution screening of bioactive compounds from complex mixtures. *Trends in Analytical Chemistry*. 2009; 28(7) 865-877.