

We are IntechOpen, the world's leading publisher of Open Access books Built by scientists, for scientists

4,500

Open access books available

119,000

International authors and editors

135M

Downloads

Our authors are among the

154

Countries delivered to

TOP 1%

most cited scientists

12.2%

Contributors from top 500 universities



WEB OF SCIENCE™

Selection of our books indexed in the Book Citation Index
in Web of Science™ Core Collection (BKCI)

Interested in publishing with us?
Contact book.department@intechopen.com

Numbers displayed above are based on latest data collected.
For more information visit www.intechopen.com



Unsteady Flows in Turbines

Lei Qi and Zhengping Zou
*Beihang University
China*

1. Introduction

In order to satisfy the growing requirements of high performance aircraft, especially the civil aircraft, for increasing the economy, safety and environment protection, etc., it is imperative to understand the noise generation and control. Engine noise is one of the most important sources of aircraft noise. The main sources of noise in a high-by-pass turbofan engine, which is widely used in modern civil transport, include fan/compressor noise, combustion noise, turbine noise and jet noise. The periodic relative motion of the adjacent rows of blades is the essence of turbomachinery as used in aero engine. Fans, compressors and turbines each can generate significant tonal and broadband noise. The generation mechanisms of the noise include inlet distortion, wakes, potential interaction, tip leakage vortex, shock waves, separation flow, and so on. The interactions between rotating and stationary blade rows can cause unsteady aerodynamic force on blade surface, and thus cause the blade-passing-frequency tonal noise. And the broadband noise is generated by the interaction of the blades with random turbulence in boundary layers, wakes, vortex shedding, separation flow, etc. In turbomachinery, the interaction noise is sensitive to axial spacing between rotor and stator and choice of blade counts. Research indicates that increasing the axial spacing between rotors and stators or choosing appropriate blade number can effectively reduce the interaction noise (Crigler & Copeland, 1965; Benzakein, 1972; Tyler & Sofrin, 1962; Duncan et al., 1975). Besides, changing the phase distribution of rotor-stator interaction or using three-dimensional blade design can both reduce the interaction tonal noise in turbomachinery (Nemec, 1967; Schaub & Krishnappa, 1977; Mellin & Sovran, 1970; Suzuki & Kanemitsu, 1971).

Therefore, one of the most significant contributions to the gas turbine engine noise is due to the unsteady interactions in turbomachinery. An in-depth understanding of the unsteady flow mechanism is crucial for the effective control and reduction of the engine noise, which is especially important for the development of high performance aircraft engine. The aim of this chapter is to briefly introduce an overview of the published work about the unsteady flow in turbomachines. With a brief discussion of the basic concepts and characteristic parameters of unsteady flow, the chapter focuses on the primary unsteady flow phenomena in turbine components, including in low-pressure turbines and in high-pressure turbines. This chapter also discusses briefly the numerical methods that are applied to unsteady flow in turbomachinery. It is important to note that the contents are mainly based on the knowledge and experience of the authors. No attempt of a comprehensive overview is intended.

1.1 Turbomachinery flows

Turbomachinery flows are among the most complex flows encountered in fluid dynamic practice (Lakshminarayana, 1991). The complexity is mainly reflected in the following areas (Chen, 1989): (1) Various forms of secondary flow caused by viscosity and complex geometry, which is dominated by vortex flows: passage, leakage, corner, trailing, horseshoe and scraping vortices, etc. These form three-dimensional and rotational nature of the flow. (2) Inherent unsteadiness due to the relative motion of rotor and stator blade rows in a multi stage environment. (3) The flow pattern in the near-wall region includes: laminar, transitional and turbulent flows; besides separated flows are often exist. (4) The flow may be incompressible, subsonic, transonic or supersonic; some turbomachinery flows include all these flow regimes. (5) Due to the limitation of flow space, there are strong interactions of the solid wall surfaces with above complicated phenomena. Besides, in gas turbines, the use of cooling gas makes the flow more complex.

1.2 Unsteady flow phenomena in turbines

Flow in turbine blade rows is highly unsteady because of the periodically encountered flow distortions generated by the upstream and downstream blade rows. This unsteadiness has important consequences for the turbine stage efficiency, blade loading, mechanical fatigue due to blade flutter, heat transfer issues, thermal fatigue and noise generation. The induced unsteady flow depends on the scale of the disturbances. Usually in turbomachinery it includes two meanings (Xu, 1989): The first is the instability of the flow field. Such as the rotating stall, surge, flutter and flow distortion, etc, which must be avoided in design. The second is the inherent unsteadiness mainly due to the relative motion of rotor/stator blade rows in a multistage environment. These form unsteady characteristics with broad spectrum, as shown in Fig. 1. In this chapter the discussion will focus on the second category unsteady flows. The main generating factors of these unsteady flows can be classified based on the physical mechanisms involved as:

1. **Potential interaction.** The potential field associated with a blade row can propagate both upstream and downstream. The magnitude of this effect depends on the Mach number and the axial distance from the blade row. In high Mach number flows, potential interactions will tend to be stronger than at lower Mach numbers.
2. **Wakes.** Unlike the potential influence, a blade wake is only convected downstream. A wake profile can be characterized by a velocity deficit, and the static pressure in it does usually not vary significantly. It can influence the surface pressure, heat transfer and boundary layer nature of the downstream blades.
3. **Shock wave interaction.** When a turbine operates in the transonic regime, shock wave occurs. In addition to the losses produced by the periodic movement of the shock itself, the shock wave can cause intense unsteady effect.
4. **Streamwise vortices.** In low aspect ratio blade rows, the secondary flow and tip leakage flow, etc, in the form of streamwise vortices are significant. These vortices are convected downstream towards the next blade row where they interact with the main flow. They have an important effect on the flow distribution for the downstream blade rows.
5. **Hot streaks.** At the exit of combustor, there is a hot streak with temperature non-uniformities in both radial and azimuthal directions. It is convected downstream and will have significant effects on both the aerodynamic and the heat transfer for the downstream blade rows.

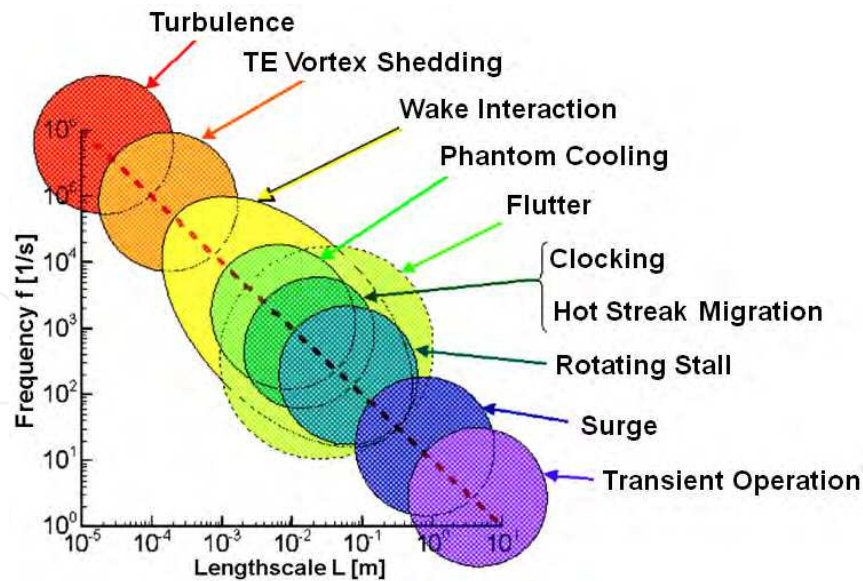

Fig. 1. Flow structures with 5 to 6 orders of magnitudes variations in length and time scales (LaGraff et al., 2006)

1.3 Unsteady flow effects on turbine performance

The impact of unsteady flow on turbomachinery performance has been extensively studied in recent decades. For the unsteady flow effects in turbomachinery, it is a source of aerodynamic noise to the acoustics experts, and it is a source of mechanical vibration to the aeroelasticity experts. For the aerodynamic designers, however, the interpretation of the unsteady flow effects in turbomachinery is still a controversial subject, which means that it can both have favorable or unfavorable influence on performance. In the past, the common opinion says that unsteadiness always brings a decrease in efficiency (Boletis & Sieverding, 1991; Sharma et al., 1992; Funazaki et al., 1997; Schulte & Hodson, 1998), such as the increase of losses, resistance and measurement errors, etc. With the deepening of understanding about the unsteady mechanisms, people gradually realize that the unsteady flow effects has a kind of latent benefit, such as the wake recovery effect, wake-boundary layer interaction (calming effect), clocking effect and hot steaks, etc.

So far, the design systems of turbomachinery are mostly based on the assumption of steady flow. Due to the lack of the realistic models for loss generation in the unsteady flow environment, designers rely on the use of experience factors for steady state loss correlations to account for these unsteady effects (Dunham, 1996). However, these factors do not necessarily reflect the true physical nature of the loss generation mechanisms in the unsteady environment. In most instances, the method based on the steady flow assumption captures the main features of the flow and we can get a high performance result. However, in high-load or off-design conditions, the performance is not satisfactory. One of the main reasons is the neglect of flow unsteadiness in actual turbomachinery. In turbine stage environment, the flow is periodic unsteady due to the relative motion of the blade rows. As modern engine design philosophy places emphasis on higher blade loading and smaller engine length, the effects of these unsteady interactions become even more important. The turbine design, up to now, has developed to a rather high level with the increasingly mature of the design technology. It is hard to make further improvement on the turbine performance under present design concept.

Therefore, it is necessary to consider the effects of unsteady flow, which have been neglected in present design and do have great effects on the performance. At present the problems we need to resolve are as follows. Which unsteady effects are the most significant ones and need to be given special consideration? How can we introduce these unsteady effects into the turbomachinery design system?

2. Basic concepts and characteristic parameters of unsteady flows

2.1 Definitions of loss coefficient

In a turbomachinery, any flow feature that reduces the efficiency will be called loss (Denton, 1993). There are many different definitions of loss coefficient in regular use for individual blade rows. Denton (1993) has given a detailed description about the loss coefficient definitions. The most useful loss coefficient for design purposes is the energy or enthalpy loss coefficient. For a turbine blade it is defined as,

$$\zeta = \frac{h_2 - h_{2s}}{h_{o2} - h_2} \quad (1)$$

where the isentropic final enthalpy, h_{2s} , is the value obtained in an isentropic expansion or compression to the same final static pressure as the actual process.

Entropy rise is one of the most commonly definitions of loss coefficient. Denton (1993) clearly illustrates that the only accurate measure of loss in a flow is entropy. Entropy is a particularly convenient measure because, unlike stagnation pressure, stagnation enthalpy or the kinetic energy, its value does not depend upon the frame of reference. It can be derived from the second law of thermodynamics that the entropy rise can be written as,

$$\Delta s = c_p \ln \frac{T}{T_{ref}} - R \ln \frac{p}{p_{ref}} \quad (2)$$

For adiabatic flow through a stationary blade row stagnation temperature is a constant and entropy rise depends only on stagnation pressure changes. So Equation 2 can be written as,

$$\Delta s = -R \ln \left(\frac{p_{o2}}{p_{o1}} \right) \quad (3)$$

For a turbine blade, another commonly definition is the stagnation pressure loss coefficient:

$$\gamma = \frac{p_{o1} - p_{o2}}{p_{o2} - p_2} \quad (4)$$

The reason that this definition of loss coefficient is so common is that it is easy to calculate it from cascade test data and not because it is the most convenient to use in design. However, the stagnation pressure loss coefficient can only be used in a stationary blade row in which the temperature is constant, but cannot be used in a rotational blade row. In addition, there are many other loss coefficient definitions, which are presented by Denton (1993).

It should be pointed out that in steady flow, the entropy rise and the stagnation pressure loss coefficient can both be used to estimate the loss. However, in real turbomachinery the flow is unsteady, and both the relative stagnation pressure and temperature can change. It

follows that the loss coefficient should be expressed in terms of entropy, which accounts for both pressure and temperature changes. For example, experiment research by Mansour et al. (2008) showed that the overall losses and the loss distributions are misrepresented by the stagnation pressure loss coefficient. The overall losses are overestimated by more than 69% using the stagnation pressure loss coefficient. Furthermore the entropy loss coefficient identifies the tip leakage vortex as the most loss region, followed by the lower passage vortex, and then the upper passage vortex. On the other hand in terms of the stagnation pressure loss coefficient, the order of decreasing loss generation is lower passage vortex, upper passage vortex and tip leakage vortex.

The reason for this phenomenon is the isentropic rearrangement of the temperature and pressure, known as energy separation (Greitzer et al., 2004; Hodson & Dawes, 1998). It is well known that the stagnation enthalpy of a particle changes as it traverses an inviscid flow where the static pressure fluctuates. This may be written as,

$$\frac{Dh_o}{Dt} = \frac{1}{\rho} \frac{\partial p}{\partial t} \quad (5)$$

And the second law of thermodynamics relates changes in stagnation pressure and stagnation enthalpy by,

$$T_o ds = dh_o - \frac{1}{\rho_o} dp_o \quad (6)$$

From Equation (5) and (6) it can be seen that pressure changes with time not only influence the distribution of stagnation temperature, but also influence the stagnation pressure distribution by stagnation enthalpy. A detailed interpretation of the energy separation is presented by Greitzer et al. (2004). Thus, in unsteady flow field, we can only use entropy loss coefficient to represent a loss, due to the energy separation effect.

A better parameter of loss definition is the entropy generation, which is computed locally and has not to be given a reference value. The advantage of using entropy generation is to assess if and where the design could be improved. By evaluating the entropy generation in a control volume and summing many such control volumes in a blade passage, it is also possible to calculate the entropy increase for the whole blade row. Chaluvadi et al. (2003) introduced one of the methods to compute the entropy generation. According to the energy equation (Hughes & Gaylord, 1964), for a volume of "V", with a surface area "A", the rate of entropy production due to viscous dissipation can be written as,

$$\int_V \sigma dvol + \int_A \frac{k \nabla T}{T} \vec{n} dA = \frac{\partial}{\partial t} \int_V \rho s dvol + \int_A \rho s \vec{V} \vec{n} dA \quad (7)$$

where σ is the entropy production rate per unit volume due to viscous shear and k is the thermal conductivity. The unit normal vector \vec{n} is positive when directed out of the volume and the velocity vector is denoted as \vec{V} .

2.2 Characteristic parameters of unsteady flows

The strength of flow unsteadiness can be evaluated by the Strouhal number, as

$$St = L / V_0 t_0 \quad (8)$$

where L , V_0 , t_0 is the characteristic length, velocity and time, respectively. To a periodic vibration situation, for a frequency of " f ", the Strouhal number can be written as,

$$St = fL / V_0 \quad (9)$$

In turbomachinery, the Strouhal number is equivalent to the frequency of unsteady disturbing sources, known as the reduced frequency. The reduced frequency is the ratio of time taken by the given particle for convection through the blade passage to the time taken for the rotor to sweep past one stator passage. It is expressed as (Lighthill, 1954):

$$\bar{f} = \frac{f \cdot s}{V_x} = \frac{\text{Convection time}}{\text{Disturbance time}} \quad (10)$$

where f is the blade passing frequency, s is the blade pitch, and V_x is the axial velocity at the blade exit. The magnitude of the reduced frequency is a measure of the degree of unsteady effects compared to quasi-steady effects. If $\bar{f} \gg 1$, unsteady effects are significant and dominate the flow field, when $\bar{f} \approx 1$, unsteady and quasi-steady effects coexist. The reduced frequency \bar{f} also represents the number of wakes (or other upstream unsteady features) found in a single blade passage at any instant in time.

3. Unsteady flows in low-pressure turbines

3.1 Introduction

Denton (1993) said: "The historical breakdown of loss into 'profile loss,' 'endwall loss,' and 'leakage loss' continues to be widely used although it is now clearly recognized that the loss mechanisms are seldom really independent." In low-pressure turbine blades, the profile loss is generally the largest single contributor to the total loss of efficiency, because of high aspect ratio of the blades. And the magnitude of the profile loss depends mainly on the development of the blade boundary layers, especially those on the suction surfaces.

The flow in low-pressure turbines is inherently unsteady caused by the relative motion of adjacent blade rows. There are two primary forms of periodic unsteadiness: the wakes from the upstream blade rows and the potential fields of blade rows both upstream and downstream. Potential interactions are weaker than wake interactions in most low-pressure turbines (Hodson & Howell, 2005). However, research indicates that only small changes in the static pressure field may alter the behavior of boundary layers that are close to separation or have separated on the rear of the suction surface of a blade (Opoka et al., 2006; Opoka & Hodson, 2007). Thus, care must be taken when dismissing the significance of potential interactions entirely. We will focus our discussion on the wake interactions in the present contents. This is because the wake interaction plays an important role in the development of the blade boundary layers, and with it the profile loss of the blades.

3.2 Wake transport mechanisms

The wake can be defined as any velocity deficit in the body-relative frame of reference occurring in a space much smaller than the one analyzed. There is a tendency for the wake fluid to be separated from the inviscid flow rather than mix (Casciaro, 2000). If the instantaneous velocity field is decrease of the undisturbed value, a wake looks like a facing backward jet, which is the so-called "negative jet". Many researchers have confirmed the

negative jet theory in axial turbine as being the main unsteady transport mechanism. Meyer (1958) was one of the first to use the negative jet theory to explain the unsteady behavior in compressor stages. Kerrebrock & Mikolajczak (1970) observed that in a compressor the pressure side presence hinders the wake transport and consequently the stator wake fluid accumulates on the rotor pressure side, tending to decrease the load on a compressor blade. On the contrary in turbines, it looks like that the negative jet of the wake impinges on the rotor suction side, tending to increase the blade loads.

The convection of the upstream wake segment within the blade row is characterized by bowing, reorientation, elongation, and stretching (Smith, 1966; Stieger & Hodson, 2005), as Fig. 2 shows. Bowing of the wake fluid originates near the leading edge plane where the mid-passage velocities are higher than the velocities near the blade surfaces. The reorientation of the wake segment occurs due to the circulation of the blade. The velocities near the suction surface are higher than near the pressure surface, and therefore, fluid near the suction surface convects through the passage more rapidly, resulting in a reorientation of the wake segment. The difference in convection velocities also causes the wake segment to elongate, and this, in turn, decreases the wake width to conserve the vorticity of the wake fluid. Stretching occurs as the first part of the wake reaches the leading edge.

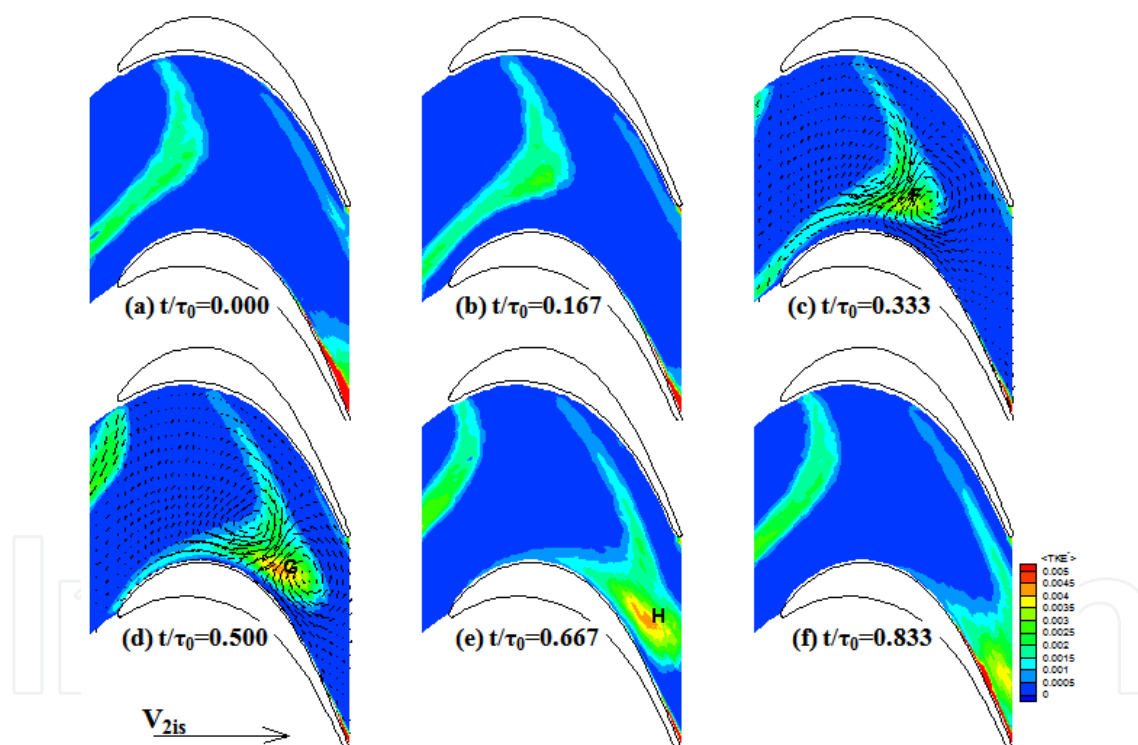

Fig. 2. Unsteady wakes convecting in blade passage (Stieger & Hodson, 2005)

The concept of the “wake avenue” was first introduced by Binder et al. (1989). Fig. 3 shows the progress of wakes through downstream blade rows. It can be seen from the plot that in the relative frame, the wake segments from the same rotor are arranged along a fixed path towards the downstream rotor. Differences in the number of rotor blades in the upstream and downstream blade rows cause the downstream flow field to be dependent upon the relative position of the upstream blade. This phenomenon is quasi-steady in the relative frame. It has also been observed in the tests carried out by other researchers (Miller et al., 2003).

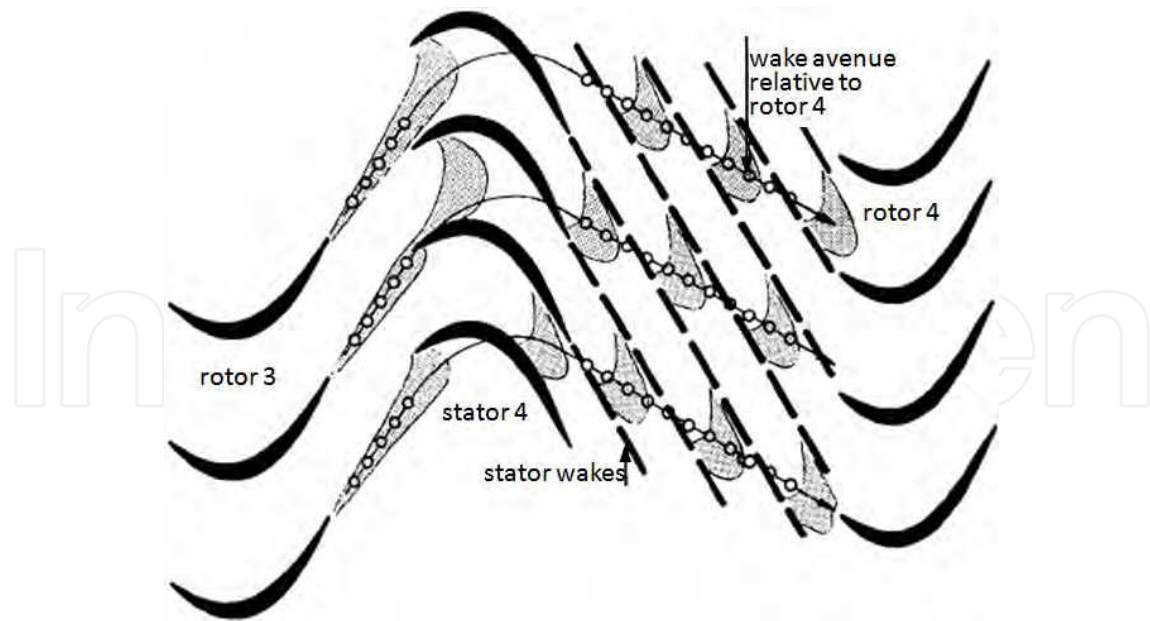

Fig. 3. Schematic diagram of the wake avenue (Binder et al., 1989)

The transport of the wakes can have an impact on performance by mechanisms other than boundary layer response. Valkov & Tan (1999a) indicates, in compressors, there is a generic mechanism with significant influence of wake transport on performance: reversible recovery of the energy in the wakes (beneficial). The loss created during the mixing of a wake with velocity deficit ΔV is proportional to ΔV^2 (Denton, 1993). The blade wake is stretched inviscidly as it is convected downstream so that, by Kelvin's circulation theorem, the velocity deficit must decrease (as shown in Fig. 4a), and with it the viscous mixing loss. Besides, the tip leakage vortex has the same effect mechanism as a wake (see Valkov & Tan, 1999b). That is why, in compressors, mixing out the wake within the blade row will generate less loss overall than if we had mixed it out upstream of the blade row. And the impact of interaction with upstream wakes becomes more significant at reduced axial spacing.

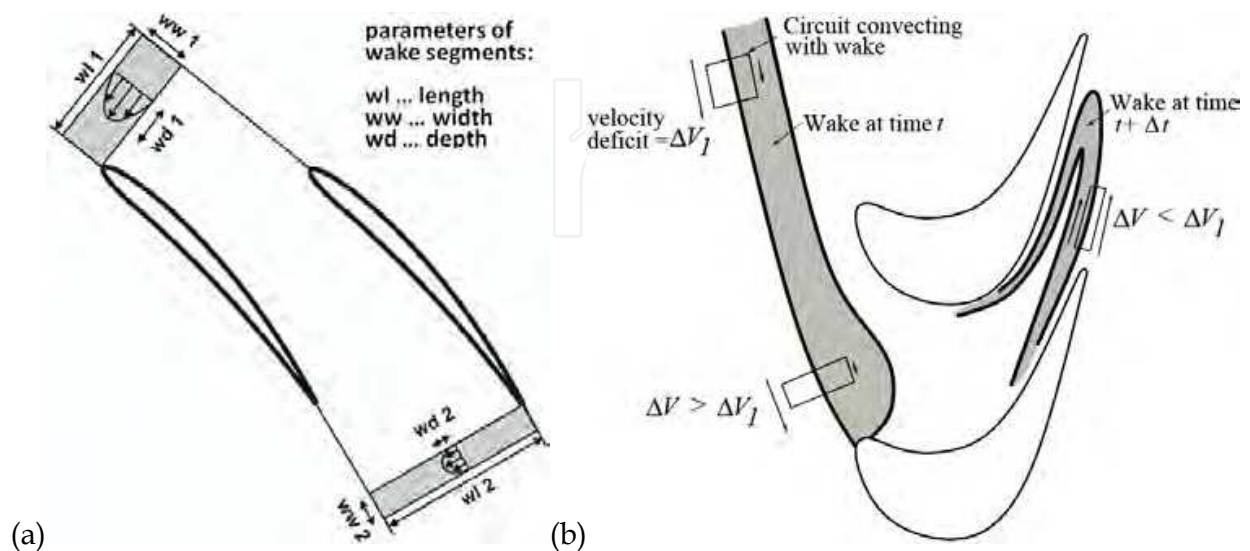

Fig. 4. Schematic diagram of wake transport: (a) in compressors (Mailach & Vogeler, 2006); (b) in turbines (Pullan, 2004)

The influence of the wake transport on performance is different in turbines. As shown in Fig. 4b, although the mixing losses of the wake increase as it is compressed near the leading and reduce as it is stretched through the passage, the converse occurs when streamwise vorticity (include the passage vortex and tip leakage vortex, etc.) enters the next blade row. Thus, in turbines, with some factors tending to increase entropy production and some reduce it, we cannot be certain whether mixing out the inlet flow within the rotor will generate more loss overall than if we had mixed it out upstream of the blade row.

3.3 Wake-boundary layer interaction

In low-pressure turbines, the wakes from upstream blade rows provide the dominant source of unsteadiness. Under low Reynolds number conditions, the boundary-layer transition and separation play important roles in determining engine performance. An in-depth understanding of blade boundary layer spatio-temporal evolution is crucial for the effective management and control of boundary layer transition or separation, especially the open separation, which is a key technology for the design of low-pressure turbines with low Reynolds number. Thus it is very important to research the wake-boundary layer interaction.

A comprehensive review of transition in turbomachinery components is given by Mayle (1991). He lists the four modes of transition and describes the mechanism: (a) Natural transition: the amplification of Tollmien-Schlichting instability waves in low free stream turbulence. (b) Bypass transition: caused by large disturbances, such as high free stream turbulence. (c) Separated-flow transition: caused by the laminar separation bubbles. (d) Periodic-unsteady transition: caused by the impingement of upstream periodic wakes. The periodic-unsteady transition is the characteristic mode in turbomachinery.

In low-pressure turbines with low Reynolds number, boundary layer separation may occur as the blade load increases. Rational use of the upstream periodic wakes can effectively inhibit the separation by inducing boundary layer transition before laminar separation can occur, so as to control loss generation. A comprehensive and in-depth research of wake-boundary layer interactions in low-pressure turbines is given by Hodson & Howell (2005). They summarized the processes of wake-induced boundary-layer transition and loss generation in low-pressure turbines. The schematic time-space diagram of wake-induced transition before separation is shown in Fig. 5a. The deep blue region denotes the turbulent wedge that results from the wake-induced strip, and followed immediately by the calmed region (light blue region) (The schematic plot of a turbulent spot is shown in Fig. 5b). The red region denotes the separation region. The periodic wake-boundary layer interaction process is as follows: When the wake passes, the wake-induced turbulent spots form within attached flows in front of the separation point. The turbulent spots continue to grow and enter into the separation zone, and consequently inhibit the formation of separation bubble. The calmed region trails behind the turbulent spots. It is a laminar-like region, but it has a very full velocity profile. The flow of the calmed region is unresponsive to disturbances. Consequently, it remains laminar for much longer than the surrounding fluid and can resist transition and separation. It is the combination of the calming effect and the more robust velocity profile within the calmed region that makes this aspect of the flow so important. After the interaction of the wake, boundary layer separation occurs in the interval between the two wakes.

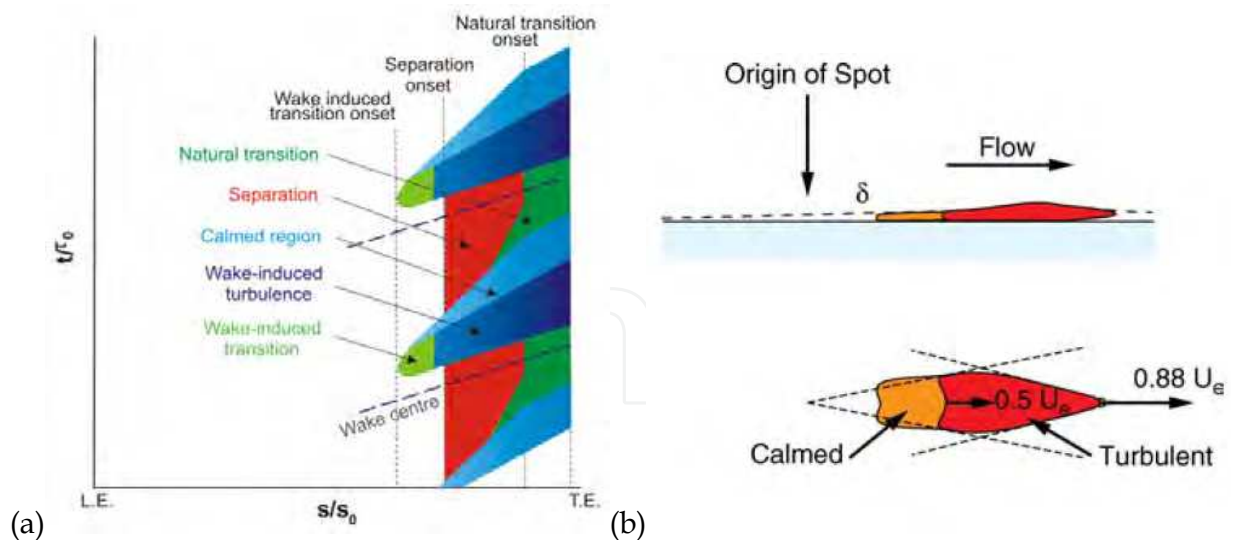

Fig. 5. Schematic diagram of wake-boundary layer interaction model : (a) the time-space diagram (Zhang & Hodson, 2004); (b) the turbulent spot (Hodson & Howell, 2005)

It can be concluded from Fig. 5 that the upstream wake-passing frequency is an important factor, which can influence the development of the boundary layers. It can effectively inhibit the boundary layer separation with appropriate wake-passing frequency, i.e., before the calmed region induced by the former wake disappears, the next wake has arrived in the area to be separated. At present, many researchers have basically understood the application of this technology in turbine design (e.g. Haselbach et al., 2002; Uliza & González, 2001).

3.4 Clocking effects

The real flow in multistage turbomachines is inherently unsteady because of the relative blade row motion. This causes unsteady interactions of pressure fields, shock waves, and wakes between stators and rotors. In recent years clocking of stator/rotor blade rows in multistage axial compressors and turbines has become an important scope of scientific investigations aiming to reduce aerodynamic losses and increase aerodynamic load. Clocking effect is to influence the unsteady flow field in multistage turbomachinery by changing the relative circumferential positions of either adjacent stator/rotor rows preferably with the same blade count.

The influence of clocking effects on aerodynamic performance is: the greatest benefits are achieved when the wake of upstream stator/rotor just impinges on the 2nd stator/rotor leading edge, while an efficiency drop was observed if the wake path entered the mid-channel (e.g. Arnone et al., 2003). Therefore, the aim of clocking is to find a relative circumferential position of successive rows of stators/rotors, so that the low momentum region in the wake of the upstream stator/rotor rows impinges the leading edge of the stator/rotor rows of the following stage.

The physical mechanism of clocking effects is as follows: when the relative circumferential positions of adjacent stator/rotor rows change that the upstream wake entering the passage also changes. It can have different impacts on the boundary layer and separation flow of the downstream blade rows, and result in the change of the transition point, separation point, and separation size in the boundary layers of blades, which will influence the efficiency of the stage. So it is important to study the effect of wake-boundary layer interactions on the clocking effects.

In the application of clocking effects, the axial and circumferential relative position of the rows, together with the blade count ratio between consecutive fixed and rotating rows, impact on the flow field unsteadiness, and consequently on the performance. Larger efficiency benefits can be achieved if the blade count ratio of consecutive stator and rotor rows is near 1:1, while practically no effect can be detected if it is far from unity (e.g. Arnone et al., 2000). In addition, larger efficiency gains can be achieved in compressors and turbines with high aspect ratio blades, conversely smaller.

Besides the total efficiency, clocking effects can influence the unsteady blade row pressure distribution. Many authors agree on the fact that larger amplitudes of unsteady pressure on the blades correspond to higher efficiency configurations (e.g. for turbine blades: Dorney & Sharma, 1996; Cizmas & Dorney, 1999), however, contrasting behavior has also been detected (Griffin et al., 1996; Dorney et al., 2001).

3.5 Shrouded tip leakage flow interaction

The necessary clearance between the rotating and the stationary components within the turbine gives rise to a clearance flow and hence loss of efficiency. Blade sealing configurations fall into two main categories: unshrouded and shrouded blades. The most obvious effect of flow leakage over the tips of both shrouded and unshrouded blades is a change in the mass flow through the blade passage, which would lead to a reduction in work for turbines.

Due to the extensive application of the shrouded blades in low-pressure turbines, here we will focus our discussion on shrouded leakage flows. The flow over the shrouded turbine blade with a single tip seal is illustrated in Fig. 6. For shrouded turbine blades the leakage will be from upstream to downstream of the blade row and so, for a fixed total volume flow, both the blade work and the pressure drop will be reduced. The pressure difference over the shroud provides the driving force for the fluid to pass into a shroud cavity and contract into a jet. The jet mixes out in the clearance space and this mixing process creates entropy. However, it was found that entropy creation due to tip leakage flows is determined almost entirely by the mixing processes that take place between the leakage flow and the mainstream; the flow processes over the shroud mainly affect the leakage flow rate (Denton, 1993). Denton (1993) provided a simple prediction model for the tip leakage loss of a shrouded blade.

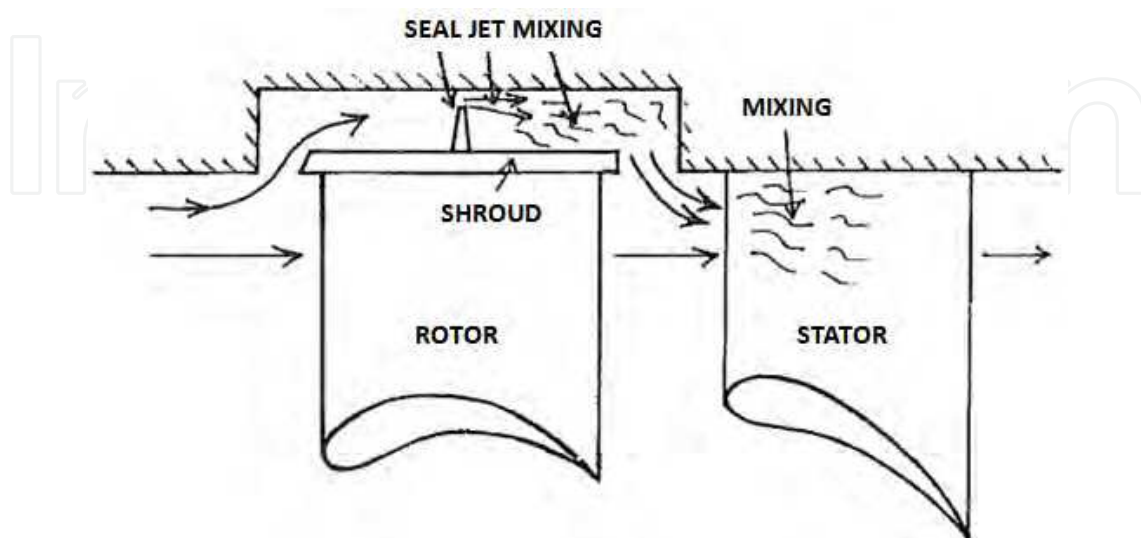

Fig. 6. Flow over a shrouded tip seal (Denton, 1993)

Little work is published on the time-resolved leakage flow-main flow interaction in shrouded axial turbines. Labyrinth leakages directly impact the boundary layers in the endwall regions before entering into the downstream row modifying the incidence angle and the secondary vortex structures (Adami et al., 2007). Denton (1993) suggested that the difference of the swirl velocity between the leakage and main flow dominates the mixing losses. The conclusion is confirmed by the research of Hunter & Manwaring (2000). However, the research by Wallis et al. (2000) has shown that although the relative swirl velocity of the leakage flow was reduced the turbine losses were increased. This indicates that a more complete understanding of unsteady interaction of the leakage flow with the main flow is required. The CFD simulations of Anker & Mayer (2002) also underlined the importance of considering unsteady measurement and simulations to obtain a more realistic representation of these effects. Hunter & Manwaring (2000) and Peters et al. (2000) showed that the size and location of the secondary flows are significantly affected by the interaction of labyrinth's leakage flow in turbines.

4. Unsteady flows in high-pressure turbines

4.1 Introduction

The blade of low aspect ratio was in popular use in recent years due to the increasing blade loading in turbomachinery (Pullan et al., 2006), especially in high-pressure and medium pressure turbines. It is well known that the loss of the flow field in the endwall regions is inversely proportional to the aspect ratio of blade. For turbines with low aspect ratio "endwall loss" (including the loss of secondary and tip leakage flows, etc.) is a major source of lost efficiency contributing even more than 60% of the total loss (Denton, 1993). The flow in high-pressure turbines is also inherently unsteady, so it is very important to consider the endwall unsteady effect in design, such as the interactions of the secondary flow vortex/tip leakage vortex with the periodic wake or potential field. Moreover in a high-loaded transonic turbine, the unsteady interactions between the shock wave and the secondary flow vortex /tip leakage vortex are also significant to the endwall loss. In order to improve the performance of high-pressure turbines, it is necessary to understand well the unsteady loss mechanisms in the endwall regions.

4.2 Shock wave interaction

It is well known that shock waves are irreversible and hence are sources of entropy. As the text books of Shapiro (1953) derive, the entropy increase across a normal or oblique shock wave varies roughly as the cube of (M^2-1) , where M is the component of Mach number perpendicular to the shock front. The pressure rise across a weak shock wave is also proportional to (M^2-1) . Oblique shocks will always produce less entropy than a normal one with the same upstream Mach number. The high-pressure turbine often operates with high pressure ratios and high Reynolds number and so shock waves do occur. Although local Mach numbers may be high, the shocks within the blade passage are usually oblique so that $\Delta P/P$ is small and they generate little direct loss (Denton, 1993).

In a transonic turbine stage with high loads, the trailing edge shocks from upstream blade rows are one of the most important sources of unsteadiness (Denton, 1993). There are indirect sources of loss associated with shock waves in transonic high-pressure turbines because of the interaction of the shock wave with the boundary layer. A boundary layer separation bubble will usually be formed at the foot of a weak shock and extra dissipation is

likely to occur within and downstream of the bubble. If the boundary layer was laminar the bubble will almost certainly cause transition. An oblique shock impingement can produce reflected shock but a normal one can't (see Fig. 7).

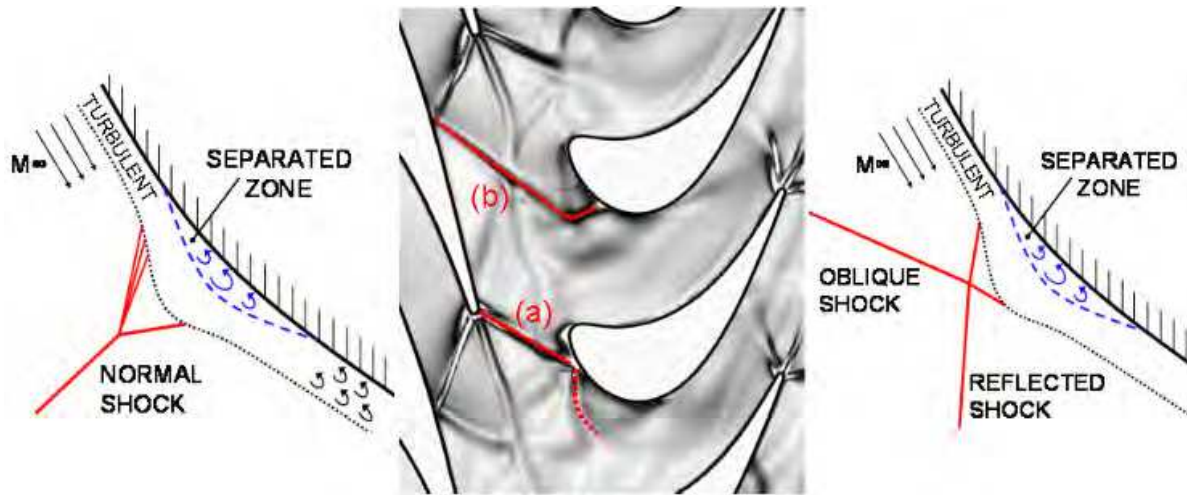

Fig. 7. Different shock-boundary layer interactions (Paniagua et al., 2007)

The motion of the upstream periodic shock waves causes the surface of the downstream blade to be subjected to a significant unsteady pressure field (see Fig. 8). When the flow unsteadiness experienced by a blade occurs at frequencies close to one of the blades' natural frequencies a significant vibration can occur. Over time this can cause high cycle fatigue and eventually, if not identified, to a catastrophic blade failure. As the trailing edge shock moves around the suction surface the vane trailing edge and the rotor leading edge form an effective throat, like Fig. 8 shows. This acts as a convergent divergent nozzle and raises the vane exit Mach number. As a rotor blade moves past a vane the divergent part of the effective nozzle gets shorter and the vane trailing edge Mach number is observed to drop.

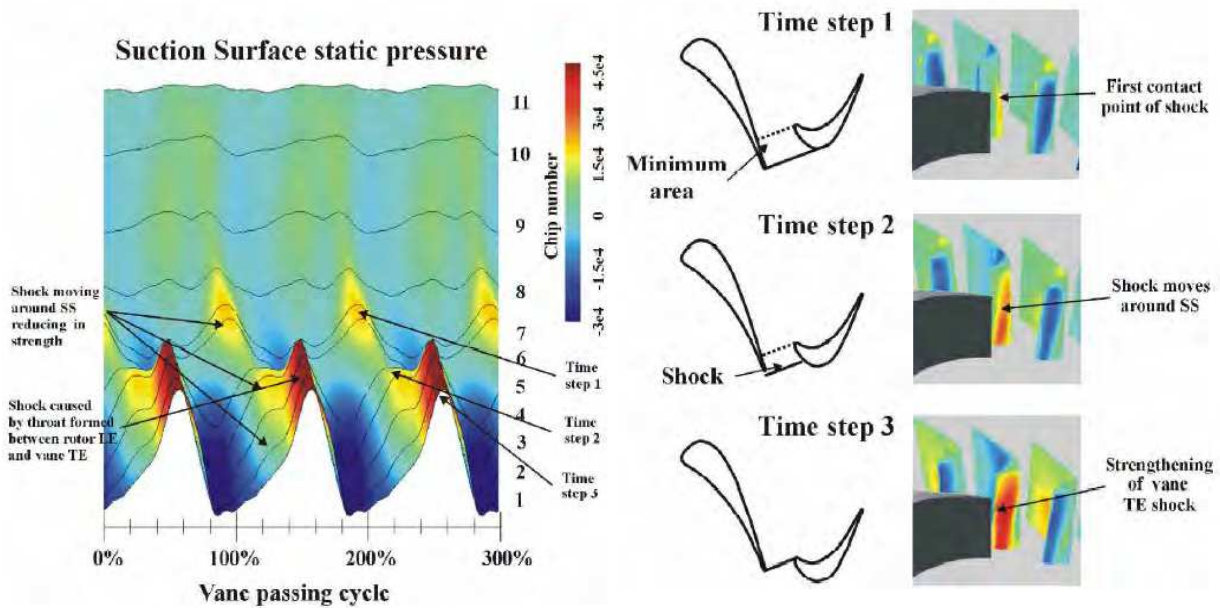

Fig. 8. The effect of upstream periodic shocks on the blade surface pressure distribution (Miller et al., 2002)

In addition, Denton (1993) said that any periodic motion of the shock itself will generate increased loss. Larger shock amplitudes cause consequently larger increases in loss. Effectively the increase in entropy generation when the shock is moving forward will be greater than the reduction when it is moving backward.

4.3 Secondary flow interaction

For high-pressure turbine blade rows with low aspect ratio the endwall losses (usually termed secondary flow losses or secondary losses) are a major source of lost efficiency contributing as high as 30-50% of the total aerodynamic losses in a blade row (Sharma & Butler, 1987). Langston (2006) said, an important problem that arises in the design and performance of axial flow turbines is the understanding, analysis, prediction and control of secondary flows. This is especially true for high-pressure turbines.

The secondary flow in a blade row can be defined as any flow, which is not in the direction of the primary or streamwise flow. The classical theories of secondary flow, as developed by Squire & Winter (1951), Hawthorne (1955) and Smith (1955) described the mechanism of the streamwise vorticity formation at blade row exit. Until now, several physical models have been developed to describe the secondary flow vortices in turbine cascade (e.g. Klein, 1966; Langston et al., 1977; Langston, 1980; Yamamoto, 1987; Wang et al., 1997), which help people have more comprehensive and vivid understanding of the secondary flow vortices structure. Review papers by Sieverding (1985), Wang et al. (1997) and Langston (2006) provide comprehensive summaries of the research on secondary flow structure and outline the most significant developments. The physical model of Wang et al. (1997) is depicted in Fig. 9. It can be seen that the passage vortex has the most significant effect on the endwall losses in turbine cascade. The classical secondary flow theories show that the flow overturning in the endwall regions and underturning in the midspan regions at the exit of the blade row.

A significant amount of research activity has recently been directed towards understanding the effect of secondary vortex unsteadiness on turbine performance. One of the major sources of unsteadiness was found to be the interaction between the streamwise vortices with the downstream blade row (e.g. Binder, 1985; Binder et al., 1986; Sharma et al., 1988). These streamwise vortices are shown to have a major influence on the secondary flow and viscous flow behavior of the downstream blade row. It has been shown, just like the wake, that the transport of streamwise vorticity can have an impact on the mixing losses in the next blade rows (Valkov & Tan, 1999b; Pullan, 2004). At the leading edge of the blade, the streamwise vortex is compressed so that, also by Kelvin's circulation theorem, the velocity deficit must decrease, and with it the rate of entropy production due to mixing. The converse occurs when the streamwise vortex is then chopped, bowed and stretched as it passes through the blade row.

In some research for multistage turbines, the blade row exit flow underturning near the hub and overturning towards the mid-span, contrary to the classical model of overturning in the endwall regions and underturning in the mid-span regions, indicating that the secondary flow is strongly influenced by the incoming secondary vortices of upstream blade row (e.g. Sharma et al., 1988; Hobson & Johnson, 1990; Chaluvadi et al., 2004). This unsteady effect raised substantial interest, as it had not been observed in the tests carried out by the other researchers (Boletis & Sieverdin, 1991; Hodson et al., 1993). It shows that the unsteady interactions on the steady performance must be related to the strength of the incoming secondary flow of the turbines.

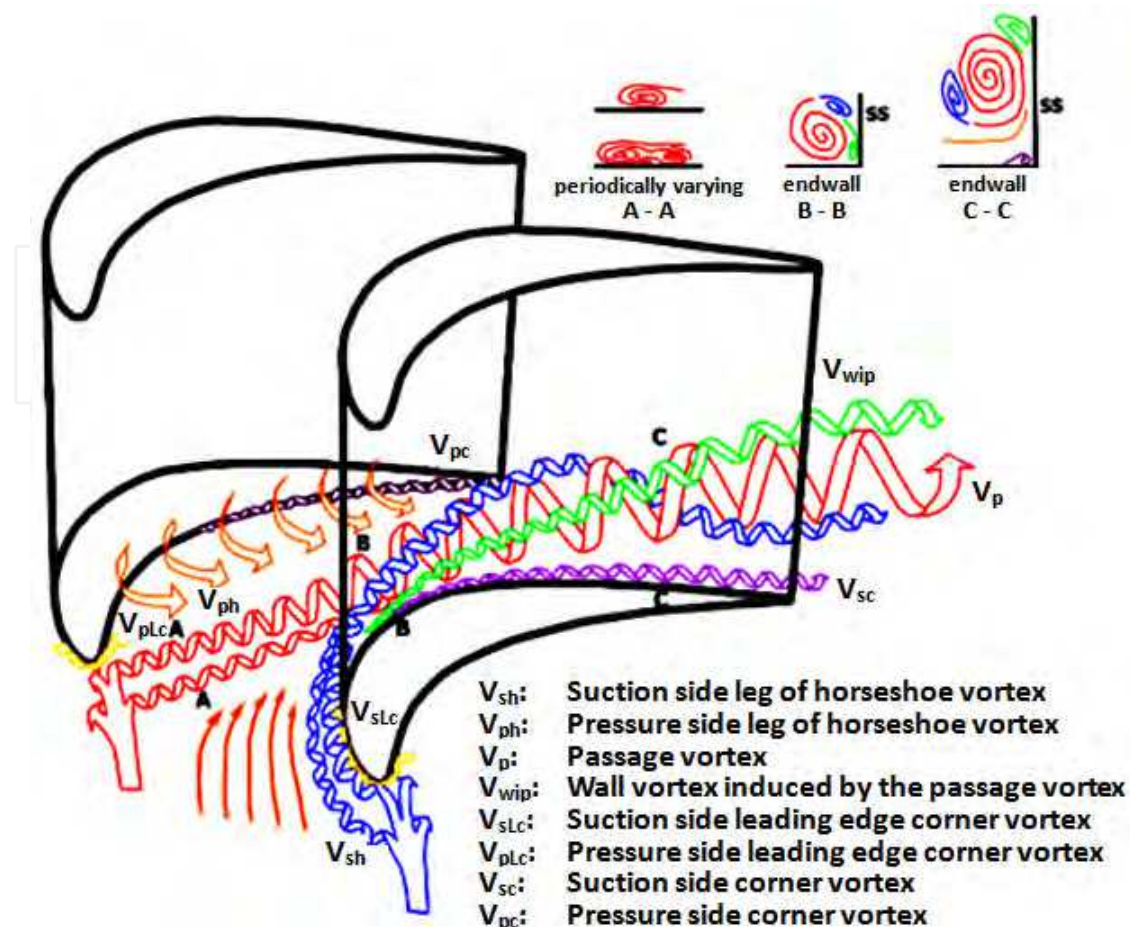

Fig. 9. Secondary flow model by Wang et al. (1997)

4.4 Unshrouded tip leakage flow interaction

The tip leakage flow is important in most turbomachinery, where a tip clearance with a height of about 1-2% blade span exists between the stationary endwall and the rotating blades. An unshrouded tip design is widely employed for a low stress and/or a better cooling in modern high-pressure turbines. Pictorial representation of the tip leakage flow in unshrouded blades is given in Fig. 10. The leakage flow over unshrouded blades occurs as a result of the pressure difference between the pressure and suction surfaces and is dominated by the vortex shed near the blade tip.

The tip leakage flow has significant effects on turbomachinery in loss production, aerodynamic efficiency, turbulence generation, heat protection, vibration and noise. As a consequence of the viscous effects, significant losses are generated by the tip leakage flow in regions inside and outside the tip gap. And the entropy creation is primarily due to the mixing processes that take place between the leakage flow and the mainstream flow. Denton (1993) gave a simple prediction model for the tip leakage loss of unshrouded blades.

So far, there are many researches about the leakage flow unsteady interactions in compressor. For example, Sirakov & Tan (2003) investigated the effect of upstream unsteady wakes on compressor rotor tip leakage flow. It was found that strong interaction between upstream wake and rotor tip leakage vortex could lead to a performance benefit in the rotor

tip region during the whole operability range of interest. The experimental result of Mailach et al. (2008) revealed a strong periodical interaction of the incoming stator wakes and the compressor rotor blade tip clearance vortices. As a result of the wake influence, the tip clearance vortices are separated into different segments with higher and lower velocities and flow turning or subsequent counter-rotating vortex pairs. The rotor performance in the tip region periodically varies in time.

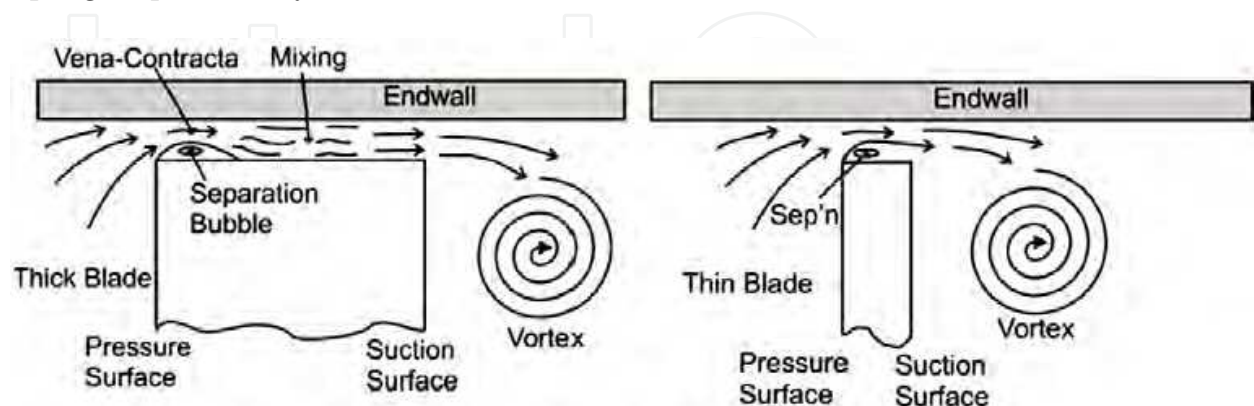

Fig. 10. Flow over an unshrouded tip gap (Zhou & Hodson, 2009, after Denton, 1993)

Compared with in compressor, very little published literature is available on the unsteady interactions between leakage flows and adjacent blade rows in turbine. Behr et al. (2006) indicated that the pressure field of the second stator has an influence on the development of the tip leakage vortex of the rotor. The vortex shows variation in size and relative position when it stretches around the stator leading edge. The present author (Qi, 2010) performed an experimental and numerical investigation of unsteady flow in the tip region of turbine with the effect of upstream wakes. The study objects included a linear turbine cascade and a turbine rotor, respectively. It shows that the presence of the upstream periodic wakes can reduce the strength and the loss of the tip leakage vortex, which is favorable to the turbine performance. In addition, due to the unsteady effect of the wakes, counter-rotating vortex pairs appear within the tip leakage vortices. These vortex pairs move downstream along the mean tip leakage vortex trajectory, which cause a significant pressure fluctuation and unsteady force on the rotor suction side.

4.5 Coolant injection and rim seal flow interactions

High-pressure gas turbines present considerable challenges to the designer because of the high aeromechanical loads at elevated temperatures. In order to cool the rotor disk and to avoid hot gas injection into the wheel space interface, cold flow is usually ejected from the cavity between the stator rim and the rotor disk. Fig. 11 illustrates a typical high-pressure gas turbine stage showing the rim seal and the wheel-space between the stator and the rotating turbine disc. Cooling air is supplied through the inner seal, and air leaves the wheel-space through the rim seal.

It was mentioned above that for high-pressure turbines, the secondary flow losses are a major source of the total aerodynamic losses in a blade row. The cooling air is injected into the mainstream and thereafter interacts with the secondary flow; consequently the turbine aerodynamic performance may be changed. So it is important to consider the coolant injection effect to the endwall region flow in unsteady environment.

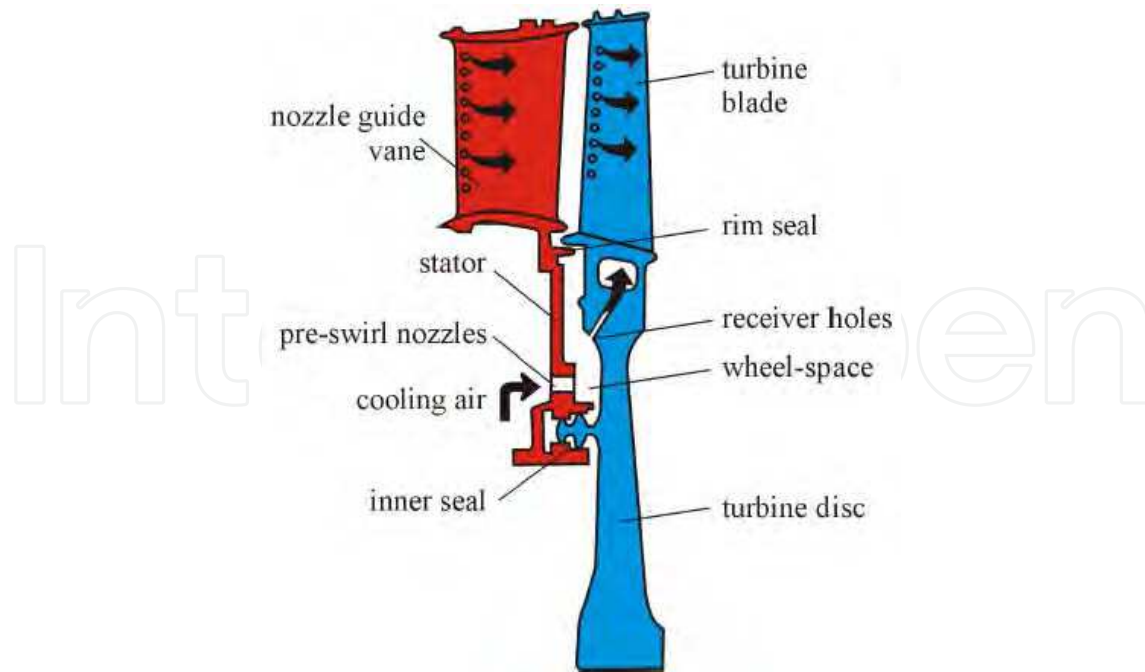

Fig. 11. Typical high-pressure turbine stage showing rim seal and wheel-space (Owen, 2009)

For subsonic turbines, the effects of rim seal purge ejection have been extensively studied in literature. It was found that even a small quantity (1 percent) of cooling air can have significant effects on the performance character and exit conditions of the high-pressure stage (McLean et al., 2001). Leakage flows from upstream cavities on engines generally emerge with lower momentum and less swirl than the mainstream flow, thus reducing the incidence at the inlet of the downstream blade row. The leakage flows may strengthen the endwall secondary flow on the downstream blade row (Anker & Mayer, 2002; Hunter & Manwaring, 2000; Paniagua et al., 2004; Pau et al., 2008). In addition, the ejection swirl angle can have a considerable effect to the efficiency of turbine stage, but the gain was restricted to the rotor due to a reduction in viscous dissipation and secondary losses (Ong et al., 2006).

In transonic turbines, trailing edge loss is a main source of losses. Denton (1993) indicates that trailing edge loss contributes even up to about 50 percent of the total two-dimensional loss in supersonic flow. The intensity of the trailing edge loss is related to the vane outlet Mach number, which is greatly affected by the rim seal. Hence, a complete study of the stator rim purge flow on transonic turbines requires not only the analysis on the downstream blade row (mixing losses and secondary flow), but the effect on the upstream transonic nozzle guide vane. Compared with in subsonic turbines, there is very little published research on transonic vane losses with rim seal. The effects of purge flow on a transonic nozzle guide vane have been studied numerically and experimentally by Pau and Paniagua (2009). In the research, a numerically predicted loss breakdown is presented, focusing on the relative importance of the trailing edge losses, boundary layer losses, shock losses and mixing losses, as a function of the purge rate ejected. Contrary to the experience in subsonic turbines, results in a transonic model demonstrate that ejecting purge flow improves the vane efficiency due to the shock structures modification downstream of the stator.

As stated previously, a small quantity of cooling air can have significant effects on the performance of the high-pressure stage. It means that the coolant injection effect should not

be negligible. However, there is little research about the coolant injection effect to the performance of high-pressure gas turbines in real unsteady environment. It needs further studies in the future.

4.6 Hot streaks

Another significant unsteady phenomenon in high-pressure turbines is the interaction of hot streaks (also called “hot spots”), which refer to the radial and circumferential temperature gradients at the gas turbine combustor exit. These pronounced temperature non-uniformities in the combustor exit flow field are caused by circumferentially discrete fuel and dilution air injection within the combustor. The hot streaks can cause significant unsteadiness due to the relative motion of the blade rows. They interact with the different turbine parts and can locally cause increased blade heat transfer leading to reduced blade life and significant risks (see Fig. 12).

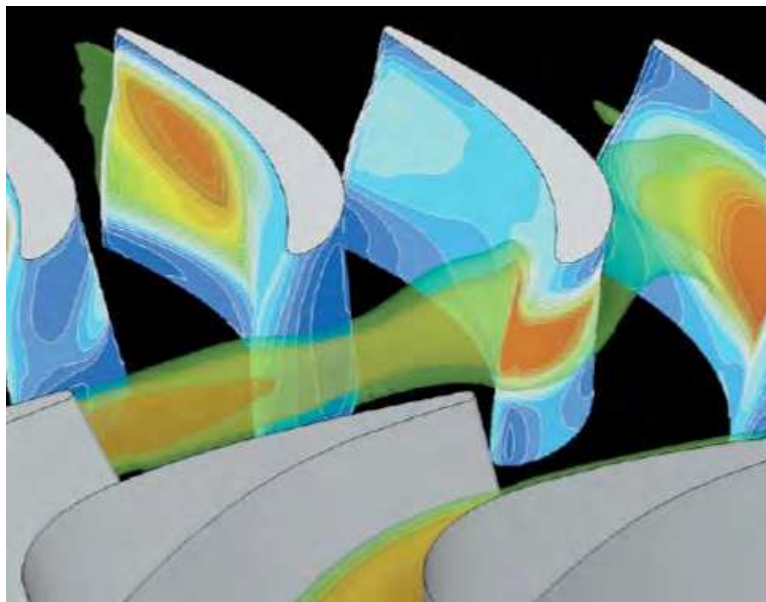

Fig. 12. Hot streaks migration (LaGraff et al., 2006)

In practical engine, combustor hot streaks can typically have stagnation temperatures twice of the free stream stagnation temperature. The hot streaks can lead to high heat loads and potentially catastrophic failure of the blades. It has been shown both experimentally and numerically that temperature gradients, in absence of total pressure non-uniformities, do not alter the flow (pressure field) within the first-stage turbine stator but do have a significant impact on the secondary flow and wall temperature of the first stage rotor (Butler et al., 1989).

An important concept is the “clocking effect of hot streaks”. Adjusting the positions of hot streaks with respect to inlet guide vanes can be used to help control blade temperatures in gas turbines. When the hot streaks impinge on the leading edge of the blade, the impact to the blade is the maximum; on the contrary the impact decrease. Although a thermal barrier coating or cooling can reduce the local heat load to a certain degree, they will obviously increase the cost. For this reason, the method of using hot streak clocking effect is proposed. Takahashi et al. (1996) and Gundy-Burlet & Dorney (1997) showed that “clocking” the hot streaks so that it is positioned at the leading edge of the vane results in a

diminishing of the effect of the hot streak on the downstream rotor. This was attributed to the deceleration and increased mixing of the hot streak as it interacted with wake of the vane. Shang & Epstein (1997) found the rotor-stator interactions between the rotor and stator can also generate significant non-uniformity of the time-averaged relative total temperature at the rotor inlet. And an optimum NGV-rotor blade count may exist that minimizes the influence of hot streaks on rotor blade life.

Another important concept is the "Kerrebrock-Mikolajczak effect" (Kerrebrock & Mikolajczak, 1970). It was a name associated with hot streak surface heating. These researchers were the first to describe why unsteady flow effects associated with compressors lead to increased pressure side heating. This effect is even more pronounced in turbines due to larger circumferential temperature variations. The description of the effect is based on the fact that the hot streak is moving at speeds significantly different from the surrounding fluid.

5. Numerical methods of unsteady flows in turbomachinery

5.1 Introduction

Computational fluid dynamics (CFD) is now more and more used to assess unsteady effects in turbomachinery flow. The application has also been extended from original academic use to industrial design application. Most of the flows encountered in turbomachinery are turbulent. Based on the Navier-Stokes equations, the numerical methods to predicting turbulent flows can be traditionally divided into three categories (Pope, 2000): Reynolds-averaged Navier-Stokes (RANS) equations, large-eddy simulation (LES) and direct numerical simulation (DNS).

5.2 Reynolds-averaged Navier-Stokes (RANS) method

The solution of the (unsteady) Reynolds-averaged Navier-Stokes (RANS) equations is a tool that is most commonly applied to the solution of turbulent flow problems, especially in engineering applications. The Reynolds-averaged method was proposed by Osborne Reynolds in 1895. In RANS method, the equations are obtained by time- (in steady flow) or ensemble-averaging (in unsteady flow) the Navier-Stokes equations to yield a set of transport equations for the averaged momentum. In the averaging processes of the equations, the presence of the Reynolds stresses causes the equations not closed. To close the equations we must introduce a turbulence model. The turbulence models have been the object of much study over the last 30 years, but no model has emerged that gives accurate results in all flows without adjustments of the model constants. This may be due to the fact that the large, energy-carrying eddies are much affected by the boundary conditions, and universal models that account for their dynamics may be impossible to develop.

Turbulence model is a key issue in CFD simulations of turbomachines. According to the decision manner of the Reynolds stresses, turbulence model can be divided into two main categories (Wilcox, 1994; Chen & Jaw, 1998): eddy-viscosity model based on the Boussinesq eddy viscosity assumption and Reynolds stress model (RSM). By the number of turbulence model equations, the Boussinesq eddy-viscosity model in numerical simulation of turbomachinery can be divided again into: algebraic model (or zero-equation model) like the mixing length model or the Baldwin-Lomax model, one-equation model like Spalart-Allmaras model and two-equation model like various $k-\epsilon$ model and $k-\omega$ model. The RSM

includes: algebraic stress model and Reynolds stress transport equation model. However, because of the complexity of turbulence model, so far there is not a universal turbulence model which can accurately simulate all types of complex flow in turbomachinery. So the formulation and proper application of the turbulence model is a key factor in the accurate prediction of the turbomachinery characteristics.

In addition, an accurate prediction of separation and transition flows is one of the important challenges to develop RANS method. Due to the complexity of separation and transition phenomenon, it is very difficult to make an accurate estimate. Many researchers have made an effort to develop and improve models for transition (Praisner & Clark, 2007; Praisner et al., 2007; Cutrone et al., 2007; Cutrone et al., 2008) in order to solve this problem. Anyhow, in the near future, practical calculations will continue to be carried out mainly by RANS methods with various turbulence models, which is still the most common and effective numerical method to solve engineering problems.

5.3 Large eddy simulation (LES)

Large eddy simulation (LES) is a technique intermediate between the solution of RANS and DNS. It is to simulate explicitly the larger-scale turbulent motions by solving the 3D time-dependent Navier-Stokes equations while model the small-scale motion that cannot be resolved on a given grid. LES can be more accurate than the (U)RANS approach and spend a lot less computational time than DNS.

The advantages of LES are as follows: firstly, compared with the large scales motion, the small scales are less affected by the boundary conditions and tend to be more isotropic and homogeneous, so are most likely to subject the universal models (Piomelli & Balaras, 2002); secondly, the large scales motion which is solved directly concludes most of the turbulent kinetic energy and can describe the main characteristics of the flow field better, so compared with RANS method, LES has some advantages (Rodi, 2000).

There are, however, many problems in actual application of LES that is the use of a subgrid-scale (SGS) model. Research indicates that the quality of the SGS models is of course an important issue in LES, which have a significant impact on the accuracy of the computational result. There are still difficulties in obtaining ideal SGS models. And also, there is the problem of huge calculated amount in LES, so it cannot become the major method in engineering practice at present.

5.4 Direct numerical simulation (DNS)

The direct numerical simulation (DNS) is a complete time-dependent solution of the Navier-Stokes equations. In DNS, all the scales of motion are resolved accurately, and no modeling is used. It is the most accurate numerical method available at present but is limited by its cost: because all scales of motion must be resolved, the number of grid points in each direction is proportional to the ratio between the largest and the smallest eddy in the flow.

Although DNS has huge calculated amount, it also has many advantages: firstly, DNS method is the most accurate method of all, because it directly solves the Navier-Stokes equations and need not introduce any models and assumptions; secondly, DNS can obtain all the details of the spatial-temporal evolution of the complex flow field, and can provide the most comprehensive numerical databases for the research of flow mechanisms; thirdly, the DNS database can be used to test other numerical simulation results, and can be of value in developing new turbulence models and subgrid-scale (SGS) models. Besides, DNS can be

used to carry out some “virtual” numerical experimentation to study the influence of single parameter on the flow field.

In the last ten years, benefiting from the improvement of computer technology and numerical method, the applications of DNS present some new characteristic features. Firstly, to some “simple” flow problems, the computational Reynolds number is becoming higher and higher, such as the simulations of channel flow (Kaneda et al., 2003; Ishihara et al., 2007). Secondly, by DNS methods, important progress was made in mechanism research on some complex flow phenomena. For example, Krishnan and Sandham has performed the direct numerical simulations to the evolution of turbulent spots in supersonic boundary layers. It reveals the basic law of turbulent spots merging, spreading and the turbulent spot-separation bubble interactions (Krishnan & Sandham, 2006a; Krishnan & Sandham, 2006b). Finally, there are a great number of mechanism researches that is about complicated engineering flow at intermediate Reynolds number condition. For example, Wu and Durbin performed the direct numerical simulation of the flow field in low-pressure turbine cascade for the first time. They studied the interactions between upstream periodic wakes and cascade flow (Wu & Durbin, 2001; Kalitzin et al., 2003).

It can be expected that a study on the complicated engineering flow by DNS method will continually go on in-depth. But it is not practical to directly use DNS to study the engineering flow. On the one hand, DNS method need for too high computer performance; On the other hand, even the computer level can meet the requirement, the mass data produced by the DNS will not be needed by engineering researchers. Hence at present and also in the foreseeable future, DNS is not a tool for engineering calculations, but a tool for mechanism researches.

5.5 Conjugate heat transfer (CHT)

With the development of modern turbine engines, the turbine inlet temperature will be further increased in order to enhance the thermal efficiency. The high temperature of hot gas far exceeds the permissible material temperature of turbine blades. Currently, using a high efficient cooling system is the common and primary way to cool blades and reduce their thermal loads. Therefore, the precondition of designing a high efficient cooling system is the accurate prediction of the temperature field of turbine blades. With the fast development of CFD and computer technology, conjugate heat transfer (CHT) method has become an effective method for the temperature prediction of turbine and other hot components.

For the traditional method of predicting temperature field, the thermal boundary conditions must be specified and it requires tedious and costly iteration that involves sequentially performing numerical predictions of flow/temperature field of the hot gas and temperature field of blades. This method is a “decoupled” method and thus the results are unreliable. Instead, CHT method method is a more efficient and accurate way to predict temperature field. The flow/temperature field of the fluid (hot gas) and temperature field of solid (blades) are solved simultaneously and the temperature and heat flux are exchanged at fluid/solid interface during each iteration step. The CHT method is a “coupled” method and thus the results are more reliable.

The early studies of flow/temperature field coupled problem focused on basic studies, such as the work of Perelman (1961) and Luikov et al. (1971). With the fast development of CFD technology and computer hardware, it is possible to carry out full 3D conjugate heat transfer (CHT) calculation. At present, the relatively mature CHT methods or programs are: the

CHTflow solver developed by Bohn et al. (1995) at Aachen University, the Glenn-HT code developed by Rigby & Lepicovsky (2001) at NASA Glenn Research Center, the Glenn-HT/BEM code developed by Heidmann et al. (2003) and Kassab et al. (2003) at NASA Glenn Research Center, the HybFlow-Solid_CHT solver developed by Montomoli et al. (2004) at Florence University, the 2-D and 3-D conjugate heat transfer prediction codes from Han et al. (2000) at University of Texas the fully coupled conjugate heat transfer (CHT) code from Croce (2001) at University of Udine, and so on.

6. References

- Adami, P., Martelli, F. & Cecchi, S. (2007). Analysis of the shroud leakage flow and mainflow interactions in high-pressure turbines using an unsteady computational fluid dynamics approach, *IMEchE J. Power and Energy* Vol. 221: 837-848.
- Anker, J. E. & Mayer, J. F. (2002). Simulation of the interaction of labyrinth seal leakage flow and main flow in an axial turbine, *ASME Paper GT2002-30348*.
- Arnone, A., Marconcini, M. & Pacciani, R. (2000). On the use of unsteady methods in predicting stage aerodynamic performance, *Proceedings of Conference on Unsteady Aerodynamics, Aeroacoustics and Aeroelasticity of Turbomachines*, pp. 24-36, Lyon, France.
- Arnone, A., Marconcini, M., Scotti Del Greco, A. & Spano, E. (2003). Numerical investigation of three-dimensional clocking effects in a low pressure turbine, *ASME Paper GT2003-38414*.
- Behr, T., Kalfas, A. I. & Abhari, R. S. (2006). Unsteady flow physics and performance of a one-and-1/2-stage unshrouded high work turbine, *ASME Paper GT2006-90959*.
- Benzakein, M. J. (1972). Research on fan noise generation, *J. Acoustical Society of America* Vol. 51(No. 5A): 1427-1438.
- Binder, A. (1985). Turbulent production due to secondary vortex cutting in a turbine rotor, *J. Engineering for Gas Turbines Power* Vol. 107: 1039-1046.
- Binder, A., Forster, W., Mach, K. & Rogge, H. (1986). Unsteady flow interaction caused by stator secondary vortices in a turbine rotor, *ASME Paper 86-GT-302*.
- Binder, A., Schroeder, T. & Hourmuzziadis, J. (1989). Turbulence measurements in a multistage low pressure turbine, *ASME J. Turbomachinery* Vol. 111: 153-161.
- Bohn, D., Bonhoff, B. & Schöenborn, H. (1995). Combined aerodynamic and thermal analysis of a turbine nozzle guide vane, *IGTC-paper-108*.
- Boletis, E. & Sieverding, C. H. (1991). Experimental study of the three-dimensional flow field in a turbine stator preceded by a full stage, *ASME J. Turbomachinery* Vol. 113: 1-9.
- Borislav, T. S. & Choon, S. T. (2002). Effect of upstream unsteady flow conditions on rotor tip leakage flow, *ASME Paper GT2002-30358*.
- Butler, T. L., Sharma, O. P., Joslyn, H. D. & Dring, R. P. (1989). Redistribution of an inlet temperature distortion in an axial flow turbine stage, *AIAA J. Propulsion and Power* Vol. 5(No. 1): 64-71.
- Casciaro, C., Treiber, M. & Sell, M. (2000). Unsteady transport mechanisms in an axial turbine, *ASME J. Turbomachinery* Vol. 122: 604-612.
- Chaluvadi, V. S. P., Kalfas, A. I. & Hodson, H. P. (2003). Blade row interaction in a high-pressure steam turbine, *ASME J. Turbomachinery* Vol. 125: 14-24.
- Chaluvadi, V. S. P., Kalfas, A. I. & Hodson, H. P. (2004). Vortex transport and blade interactions in high pressure turbines, *ASME J. Turbomachinery* Vol. 126: 395-405.
- Chen, C. J. & Jaw, S. Y. (1998). *Fundamentals of turbulence modeling*, Taylor & Francis.

- Chen, M. Z. (1989). Aero-engine turbomachinery dynamics, *Proceedings of Aerothermodynamics Development Strategy Proseminar*, pp. 1-8, Beijing, China.
- Cizmas, P. G. A. & Dorney, D. J. (1999). The influence of clocking on unsteady forces of compressor and turbine blades, ISABE Paper 99-7231.
- Crigler, J. L. & Copeland, W. L. (1965). Noise studies of inlet-guide-vane: rotor interaction of a single stage axial compressor, NASA Technical Note, NASA TN D-2962.
- Croce, G. A. (2001). A conjugate heat transfer procedure for gas turbine blades, *Annals of N.Y. Academy of Sciences*, Vol. 934: 273-280.
- Cutrone, L., De Palma, P., Pascazio, G. & Napolitano, M. (2007). An evaluation of bypass transition models for turbomachinery flows, *International J. Heat and Fluid Flow* Vol. 28: 161-177.
- Cutrone, L., De Palma, P., Pascazio, G. & Napolitano, M. (2008). Predicting transition in two- and three-dimensional separated flows, *International J. Heat and Fluid Flow* Vol. 29: 504-526.
- Denton, J. D. (1993). Loss mechanisms in turbomachines, *ASME J. Turbomachinery* Vol. 115: 621-656.
- Dorney, D. J. & Sharma, O. P. (1996). A study of turbine performance increases through airfoil clocking, AIAA Paper 96-2816.
- Dorney, D. J., Croft, R. R., Sondak, D. L., Stang, U. E. & Twardochleb, C. Z. (2001). Computational study of clocking and embedded stage in a 4-stage industrial turbine, ASME Paper 2001-GT-509.
- Duncan, P. E., Dawson, B. & Hawes, S. P. (1975). Design techniques for the reduction of interaction tonal noise from axial flow fans, *Proceedings of Conference on Vibrations and Noise in Pump, Fan, and Compressor Installations*, pp. 143-161, University of Southampton, U.K.
- Dunham, J. (1996). Aerodynamic losses in turbomachinery, AGARD-CP-571.
- Funazaki, K., Sasaki, Y. & Tanuma, T. (1997). Experimental studies on unsteady aerodynamic loss of a high-pressure turbine cascade, ASME Paper 97-GT-52.
- Greitzer, E. M., Tan, C. S. & Graf, M. B. (2004). *Internal Flow: Concepts and Applications*, Cambridge University Press.
- Griffin, L. W., Huber, F. W. & Sharma, O. P. (1996). Performance improvement through indexing of turbine airfoils: part II - numerical simulation, *ASME J. Turbomachinery* Vol. 118: 636-642.
- Gundy-Burlet, K. L. & Dorney, D. J. (1997). Three-dimensional simulations of hot streak clocking in a 1-1/2 stage turbine, *International J. Turbo and Jet Engines* Vol. 14(No. 3): 123-132.
- Han, Z. X., Dennis, B. & Dulikravich, G. (2000). Simultaneous prediction of external flow-field and temperature in internally cooled 3-D turbine blade material, ASME Paper 2000-GT-253.
- Haselbach, F., Schiffer, H. P., Horsman, M., Dressen, S., Harvey, N. & Read, S. (2002). The application of ultra high lift blading in the BR715 LP Turbine, *ASME J. Turbomachinery* Vol. 124: 45-51.
- Hawthorne, W. R. (1955). Rotational flow through cascades: part I-the components of vorticity, *J. Mechanics and Applied Mathematics* Vol. 8: 266-279.

- Heidmann, J. D., Kassab, A. J., Divo, E. A., Rodriguez, F. & Steinthorsson, E. (2003). Conjugate heat transfer effects on a realistic film-cooled turbine vane, ASME Paper GT2003-38553.
- Hobson, D. E. & Johnson, C. G. (1990). Two stage model turbine performance characteristics, Powergen Report RD/M/1888/RR90.
- Hodson, H. P., Baneighbal, M. R. & Dailey, G. M. (1993). Three-dimensional interactions in the rotor of an axial turbine, AIAA Paper 93-2255.
- Hodson, H. P. & Dawes, W. N. (1998). On the interpretation of measured profile losses in unsteady wake-turbine blade interaction studies, *ASME J. Turbomachinery*, Vol. 120: 276-284.
- Hodson, H. P. & Howell, R. J. (2005). Bladerow interactions, transition, and high-lift aerofoils in low-pressure turbines, *Annu. Rev. Fluid Mech.* Vol. 37: 71-98.
- Hughes, W. F. & Gaylord, E. W. (1964). Basic equations of engineering science, *Schaum's Outline Series*, McGraw Hill.
- Hunter, S. D. & Manwaring, S. R. (2000). Endwall cavity flow effects on gaspath aerodynamics in an axial flow turbine: part 1 - experimental and numerical investigation, ASME Paper 2000-GT-651.
- Ishihara, T., Kaneda, Y., Yokokawa, M., Itakura, K. & Uno, A. (2007). Small-scale statistics in high-resolution direct numerical simulation of turbulence: Reynolds number dependence of one-point velocity gradient statistics, *J. Fluid Mech.* Vol. 592: 335-366.
- Kalitzin, G., Wu, X. & Durbin, P. A. (2003). DNS of fully turbulent flow in a LPT passage, *Int. J. Heat and Fluid Flow* Vol. 24: 636-644.
- Kaneda, Y., Ishihara, T., Yokokawa, M., Itakura, K. & Uno, A. (2003). Energy dissipation rate and energy spectrum in high resolution direct numerical simulations of turbulence in a periodic box, *Physics of Fluids* Vol. 15(No. 2): L21-24.
- Kassab, A. J., Divo, E. A., Heidmann, J. D., Steinthorsson, E. & Rodriguez, F. (2003). BEM/FVM Conjugate heat transfer analysis of a three-dimensional film cooled turbine blade, *Int. J. Numerical Methods for Heat & Fluid Flow* Vol. 13(No. 5): 581-610.
- Kerrebrock, J. L. & Mikolajczak, A. A. (1970). Intra-stator transport of rotor wakes and its effect on compressor performance, *ASME J. Engineering for Power* Vol. 92: 359-370.
- Klein, A. (1966). Investigation of the entry boundary layer on the secondary flows in the blading of axial turbines, BHRAT1004.
- Krishnan, L. & Sandham, N. D. (2006a). Effect of Mach number on the structure of turbulent spots, *J. Fluid Mech.* Vol. 566: 225-234.
- Krishnan, L. & Sandham, N. D. (2006b). On the merging of turbulent spots in a supersonic boundary-layer flow, *Int. J. Heat and Fluid Flow* Vol. 27: 542-550.
- LaGraff, J. E., Ashpis, D. E., Oldfield, M. L. G. & Gostelow, J. P. (2006). Unsteady flows in turbomachinery, NASA/CP-2006-214484.
- Lakshminarayana, B. (1991). An assessment of computational fluid dynamic techniques in the analysis and design of turbomachinery—the 1990 freeman scholar lecture, *J. Fluids Engineering* Vol. 113(No. 3): 315-352.
- Langston, L. S., Nice, M. L. & Hooper, R. H. (1977). Three-dimensional flow within a turbine cascade passage, *ASME J. Engineering Power* Vol. 99: 21-28.
- Langston, L. S. (1980). Crossflows in a turbine cascade passage, *ASME J. Engineering Power* Vol. 102: 866-874.

- Langston, L. S. (2006). Secondary flows in axial turbines-a review, *Annals New York Academy of Sciences* Vol. 934: 11-26.
- Lighthill, M. J. (1954). The response of laminar skin friction and heat transfer to fluctuations in the stream velocity, *Proc. of Royal Society* Vol. 224A: 1-23.
- Luikov, A. V., Aleksashenko, V. A. & Aleksashenko, A. A. (1971). Analytical methods of solution of conjugated problems in convective heat transfer, *Int. J. Heat and Mass Transfer* Vol. 14(No. 8): 1047-1056.
- Mailach, R. & Vogeler, K. (2006). Blade row interaction in axial compressors, part I: periodical unsteady flow field, *Lecture series 2006-05*, Von Kármán Institute.
- Mailach, R., Lehmann, I. & Vogeler, K. (2008). Periodical unsteady flow within a rotor blade row of an axial compressor-part II: wake-tip clearance vortex interaction. *ASME J. Turbomachinery* Vol. 130: 1-10.
- Mansour, M., Chokani, N., Kalfas, A.L. & Abhari, R.S. (2008). Impact of time-resolved entropy measurement on a one-and-1/2-stage axial turbine performance, *ASME Paper GT2008-50807*.
- Mayle, R. E. (1991). The role of laminar-turbulent transition in gas turbine Engines, *ASME Paper 91-GT-261*.
- McLean, C., Camci, G. & Glezer, B. (2001). Mainstream aerodynamic effects due to wheel-space coolant injection in a high pressure turbine stage, *ASME J. Turbomachinery* Vol. 123: 687-703.
- Mellin, R. C. & Sovran, G. (1970). Controlling the tonal characteristics of the aerodynamic noise generated by fan rotors, *ASME J. Basic Engineering* Vol. 92: 143-154.
- Meyer, R. X. (1958). The effect of wakes on the transient pressure and velocity distributions in turbomachines, *ASME J. Basic Engineering* Vol. 80: 1544-1552.
- Miller, R. J., Moss, R. W. & Ainsworth, R. W. (2002). Wake, shock and potential field interactions in a 1.5 stage turbine, part I: vane-rotor and rotor-vane interaction, *ASME Paper GT2002-30435*.
- Miller, R. J., Moss, R. W., Ainsworth, R. W. & Harvey, N. W. (2003). The development of turbine exit flow in a swan-necked inter-stage diffuser, *ASME Paper GT2003-38174*.
- Montomoli, F., Adami, P., Della Gatta, S. & Martelli, F. (2004). Conjugate heat transfer modelling in film cooled blades, *ASME Paper GT2004-53177*.
- Nemec, J. (1967). Noise of axial fans and compressors: Study of its radiation and reduction, *J. Sound and Vibration* Vol. 6(No. 2): 230-236.
- Ong, J. H. P., Miller, R. J. & Uchida, S. (2006). The effect of coolant injection on the endwall flow of a high pressure turbine, *ASME Paper GT2006-91060*.
- Opoka, M. M., Thomas, R. L. & Hodson, H. P. (2006). Boundary layer transition on the high lift T106A LP turbine blade with an oscillating downstream pressure field, *ASME GT2006-91038*.
- Opoka, M. M. & Hodson, H. P. (2007). Transition on the T106 LP turbine blade in the presence of moving upstream wakes and downstream potential fields, *ASME Paper GT2007-28077*.
- Owen, J. M. (2009). Prediction of ingestion through turbine rim seals, part 1: rotationally-induced ingress, *ASME Paper GT2009-59121*.
- Paniagua, G., Dénos, R. & Almeida, S. (2004). Effect of the hub endwall cavity flow on the flow-field of a transonic high-pressure turbine, *ASME J. Turbomachinery* Vol. 126: 578-586.

- Paniagua, G., Yasa, T., Andres de la Loma, Castillon, L. & Coton, T. (2007). Unsteady strong shock interactions in a transonic turbine: experimental and numerical analysis, ISABE Paper ISABE-2007-1218.
- Pau, M., Paniagua, G., Delhayre, D., De la Loma, A. & Ginibre, P. (2008). Aerothermal impact of stator-rim purge flow and rotor-platform film cooling on a transonic turbine stage, ASME Paper GT2008-51295.
- Pau, M. & Paniagua, G. (2009). Investigation of the flow field on a transonic turbine nozzle guide vane with rim seal cavity flow ejection, ASME Paper GT2009-60155.
- Perelman, T. L. (1961). On conjugated problems of heat transfer, *Int. J. Heat and Mass Transfer* Vol. 3(No. 4): 293-303.
- Peters, P., Breisig, V., Giboni, A., Lerner, C. & Pfof, H. (2000). The influence of the clearance of shrouded rotor blades on the development of the flowfield and losses in the subsequent stator, ASME Paper 2000-GT-478.
- Piomelli, U. & Balaras, E. (2002). Wall-layer models for large-eddy simulations, *Annual Review of Fluid Mechanics* Vol. 34: 349-374.
- Pope, S. B. (2000). *Turbulent flows*, Cambridge University Press.
- Praisner, T. J. & Clark, J. P. (2007). Predicting transition in turbomachinery, part I: a review and new model development, *ASME J. Turbomachinery* Vol. 129: 1-13.
- Praisner, T. J., Grover, E. A., Rice, M. J. & Clark, J. P. (2007). Predicting transition in turbomachinery, part II: model validation and benchmarking, *ASME J. Turbomachinery* Vol. 129: 14-22.
- Pullan, G. (2004). Secondary flows and loss caused by row interaction in a turbine stage, ASME Paper GT2004-53743.
- Pullan, G., Denton, J. D. & Curtis E. (2006). Improving the performance of a turbine with low aspect ratio stators by aft-loading, *ASME J. Turbomachinery* Vol. 128: 492-499.
- Qi, L. (2010). Investigations of unsteady interaction mechanism and flow control in the turbine endwall regions, *D. Phil. Thesis*, Beihang University.
- Rigby, D.L. & Lepicovsky, J. (2001). Conjugate heat transfer analysis of internally cooled configurations, ASME Paper 2001- GT-0405.
- Rodi, W. (2000). Simulation of turbulence in practical flow calculations, *European Congress on Computational Methods in Applied Sciences and Engineering*, Spanish Association for Numerical Methods in Engineering, Barcelona, Spain.
- Schaub, U. W. & Krishnappa, G. (1977). The stepped stator concept: Aerodynamic and acoustic evaluation of a thrust fan, *Proceedings of 4th AIAA - Aeroacoustics Conference in America USA*, American Institution of Aeronautics and Astronautics.
- Schulte, V. & Hodson, H. P. (1998). Unsteady Wake-induced boundary layer transition in high lift LP turbines, *ASME J. Turbomachinery* Vol. 120(No. 1): 28-35.
- Shang, T. & Epstein, A. H. (1997). Analysis of hot streak effects on turbine rotor heat load, *ASME J. Turbomachinery* Vol. 119(No. 3): 544-553.
- Shapiro, A. H. (1953). *The dynamics and thermodynamics of compressible fluid flow*, Wiley, New York.
- Sharma, O. P. & Butler, T. L. (1987). Predictions of endwall losses and secondary flows in axial flow turbine cascades, *ASME J. Turbomachinery* Vol. 109: 229-236.
- Sharma, O. P., Butler, T. L., Dring, R. P., Joslyn, H. D. & Renaud, E. (1988). Rotor-stator interaction in multistage axial flow turbines, AIAA Paper 88-3013.

- Sharma, O. P., Pickett, G. F. & Ni, R. H. (1992). Assessment of unsteady flows in turbines, *ASME J. Turbomachinery* Vol. 114(No. 1): 79-90.
- Sieverding, C. H. (1985). Recent progress in the understanding of basic aspects of secondary flows in turbine blade passages, *ASME J. Engineering Gas Turbines Power* Vol. 107: 248-257.
- Sirakov, B. T. & Tan, C. S. (2003). Effect of unsteady stator wake-rotor double-leakage tip clearance flow interaction on time-average compressor performance, *ASME J. Turbomachinery* Vol. 125: 465-474.
- Smith, L. H. (1955). Secondary flow in axial-flow turbomachinery, *ASME Transactions* Vol. 77: 1065-1076.
- Smith, L. H. (1966). Wake dissipation in turbomachines, *ASME J. Basic Engineering* Vol. 88D: 688-690.
- Squire, H. B. & Winter, K. G. (1951). The secondary flow in a cascade of aerofoils in a non-uniform stream, *J. the Aerospace Sciences* Vol. 18: 271-277.
- Stieger, R. D. & Hodson, H. P. (2005). The unsteady development of a turbulent wake through a downstream low-pressure turbine blade passage, *ASME J. Turbomachinery* Vol. 127: 388-394.
- Suzuki, S. & Kanemitsu, Y. (1971). An experimental study on noise reduction of axial flow fans, *Proceedings of 7th International Congress on Acoustics in Hungary*.
- Takahashi, R. K., Ni, R. H., Sharma, O. P. & Staubach, J. B. (1996). Effect of hot streak indexing in a 1-1/2 stage turbine, *AIAA Paper 96-2796*.
- Tyler, J. M. & Sofrin, T. G. (1962). Axial flow compressor noise studies, *Transactions of the Society of Automotive Engineers* Vol. 70: 309-332.
- Ulizar, I. & González, P. (2001). Aerodynamic design of a new five stage low pressure turbine for the Rolls Royce Trent 500 turbofan, *ASME Paper 2001-GT-0440*.
- Valkov, T. V. & Tan, C. S. (1999a). Effect of upstream rotor vortical disturbances on the time-averaged performance of axial compressor stators, part 1: framework of technical approach and wake-stator blade interactions, *ASME J. Turbomachinery* Vol. 121: 377-386.
- Valkov, T. V. & Tan, C. S. (1999b). Effect of upstream rotor vortical disturbances on the time-averaged performance of axial compressor stators, part 2: rotor tip vortex/streamwise vortex-stator blade interactions, *ASME J. Turbomachinery* Vol. 121: 387-397.
- Wallis, A. M., Denton, J. D. & Demargne, A. A. J. (2000). The control of shroud leakage flows to reduce aerodynamic losses in a low aspect ratio, shrouded axial flow turbine, *ASME Paper 2000-GT-0475*.
- Wang, H. P., Olson, S. J., Goldstein, R. J. & Eckert, E. R. G. (1997). Flow visualization in a linear turbine cascade of high performance turbine blades, *ASME J. Turbomachinery* Vol. 119: 1-8.
- Wilcox, D. C. (1994). *Turbulence modeling for CFD*, DCW Industries, Inc..
- Wu, X. & Durbin, P. A. (2001). Evidence of longitudinal vortices evolved from distorted wakes in a turbine passage, *J. Fluid Mech.* Vol. 446: 199-228.
- Xu, L. (1989). The experiment method of unsteady flow and aerodynamics in turbine, *Proceedings of Aerothermodynamics Development Strategy Proseminar, Beijing, China*.

- Yamamoto, A. (1987). Production and development of secondary flows and losses in two types of straight turbine cascades: part I-a stator case, *ASME J. Turbomachinery* Vol. 109: 186-193.
- Zhang, X. F. & Hodson, H. P (2004). Experimental study of unsteady wake-induced boundary layer transition in turbomachinery, Whittle Laboratory, University of Cambridge.
- Zhou, C. & Hodson, H. P. (2009). The tip leakage flow of an unshrouded high pressure turbine blade with tip cooling, ASME Paper GT2009-59637.

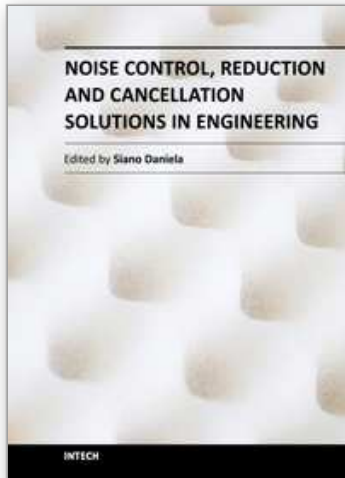

Noise Control, Reduction and Cancellation Solutions in Engineering

Edited by Dr Daniela Siano

ISBN 978-953-307-918-9

Hard cover, 298 pages

Publisher InTech

Published online 02, March, 2012

Published in print edition March, 2012

Noise has various effects on comfort, performance, and human health. For this reason, noise control plays an increasingly central role in the development of modern industrial and engineering applications. Nowadays, the noise control problem excites and attracts the attention of a great number of scientists in different disciplines. Indeed, noise control has a wide variety of applications in manufacturing, industrial operations, and consumer products. The main purpose of this book, organized in 13 chapters, is to present a comprehensive overview of recent advances in noise control and its applications in different research fields. The authors provide a range of practical applications of current and past noise control strategies in different real engineering problems. It is well addressed to researchers and engineers who have specific knowledge in acoustic problems. I would like to thank all the authors who accepted my invitation and agreed to share their work and experiences.

How to reference

In order to correctly reference this scholarly work, feel free to copy and paste the following:

Lei Qi and Zhengping Zou (2012). Unsteady Flows in Turbines, Noise Control, Reduction and Cancellation Solutions in Engineering, Dr Daniela Siano (Ed.), ISBN: 978-953-307-918-9, InTech, Available from: <http://www.intechopen.com/books/noise-control-reduction-and-cancellation-solutions-in-engineering/unsteady-flow-in-turbines>

INTECH
open science | open minds

InTech Europe

University Campus STeP Ri
Slavka Krautzeka 83/A
51000 Rijeka, Croatia
Phone: +385 (51) 770 447
Fax: +385 (51) 686 166
www.intechopen.com

InTech China

Unit 405, Office Block, Hotel Equatorial Shanghai
No.65, Yan An Road (West), Shanghai, 200040, China
中国上海市延安西路65号上海国际贵都大饭店办公楼405单元
Phone: +86-21-62489820
Fax: +86-21-62489821

© 2012 The Author(s). Licensee IntechOpen. This is an open access article distributed under the terms of the [Creative Commons Attribution 3.0 License](#), which permits unrestricted use, distribution, and reproduction in any medium, provided the original work is properly cited.

IntechOpen

IntechOpen