

We are IntechOpen, the world's leading publisher of Open Access books Built by scientists, for scientists

5,300

Open access books available

132,000

International authors and editors

160M

Downloads

Our authors are among the

154

Countries delivered to

TOP 1%

most cited scientists

12.2%

Contributors from top 500 universities



WEB OF SCIENCE™

Selection of our books indexed in the Book Citation Index
in Web of Science™ Core Collection (BKCI)

Interested in publishing with us?
Contact book.department@intechopen.com

Numbers displayed above are based on latest data collected.
For more information visit www.intechopen.com



Design of Electronic Equipment Casings for Natural Air Cooling: Effects of Height and Size of Outlet Vent on Flow Resistance

Masaru Ishizuka and Tomoyuki Hatakeyama
Toyama Prefectural University
Japan

1. Introduction

As the power dissipation density of electronic equipment has continued to increase, it has become necessary to consider the cooling design of electronic equipment in order to develop suitable cooling techniques. Almost all electronic equipment is cooled by air convection. Of the various cooling systems available, natural air cooling is often used for applications for which high reliability is essential, such as telecommunications. The main advantage of natural convection is that no fan or blower is required, because air movement is generated by density differences in the presence of gravity. The optimum thermal design of electronic devices cooled by natural convection depends on an accurate choice of geometrical configuration and the best distribution of heat sources to promote the flow rate that minimizes temperature rises inside the casings. Although the literature covers natural convection heat transfer in simple geometries, few experiments relate to enclosures such as those used in electronic equipment, in which heat transfer and fluid flow are generally complicated and three dimensional, making experimental modeling necessary. Guglielmini et al. (1988) reported on the natural air cooling of electronic boards in ventilated enclosures. Misale (1993) reported the influence of vent geometry on the natural air cooling of vertical circuit boards packed within a ventilated enclosure. Lin and Armfield (2001) studied natural convection cooling of rectangular and cylindrical containers. Ishizuka et al. (1986) and Ishizuka (1998) presented a simplified set of equations derived from data on natural air cooling of electronic equipment casings and showed its validity. However, there is insufficient information regarding thermal design of practical electronic equipment. For example, the simplified set of equations was based on a ventilation model like a chimney with a heater at the base and an outlet vent on the top, yet in practical electronic equipment, the outlet vent is located at the upper part of the side walls, and the duct is not circular. Therefore, here, we studied the effect of the distance between the outlet vent location and the heat source on the cooling capability of natural-air-cooled electronic equipment casings.

2. Set of equations

Ishizuka et al. (1986) proposed the following set of equations for engineering applications in the thermal design of electronic equipment:

$$Q = 1.78S_{eq} \Delta T_m^{1.25} + 300A_o(h/K)^{0.5} \Delta T_o^{1.5} \quad (1)$$

$$K = 2.5(1 - \beta) / \beta^2 \quad (2)$$

$$\Delta T_o = 1.3 \Delta T_m \quad (3)$$

$$S_{eq} = S_{top} + S_{side} + 1/2 S_{bottom} \quad (4)$$

where Q denotes the total heat generated by the components, S_{eq} is the equivalent total surface of the casing, ΔT_m is the average temperature rise in the casing, A_o is the outlet vent area of the casing, h is the distance from the heater position to the outlet, K is the flow resistance coefficient arising from air path interruption at the outlet, ΔT_o is the air temperature rise at the outlet vent, and β is the porosity coefficient of the outlet vent. K was approximated as a function of β : Ishizuka et al. (1986, 1987) obtained the following relation for wire nets at low values of the Reynolds number (Re):

$$K = 40(Re(1 - \beta) / \beta^2)^{-0.95} \quad (5)$$

where Re is defined on the basis of the wire diameter used in the wire nets. However, since the effect of Re on K is less prominent than that of β , K can be approximated as a function of β only. Therefore, Eq. (2) is considered to be a reasonable expression for practical applications. The h term in Eq. (1) refers to chimney height, as Eq. (1) assumes a ventilation model like a chimney with a heater at the base and an outlet vent on the top (Fig. 1). However, as practical electronic equipment is nothing like a chimney, we took practical details into account in the following experiments.

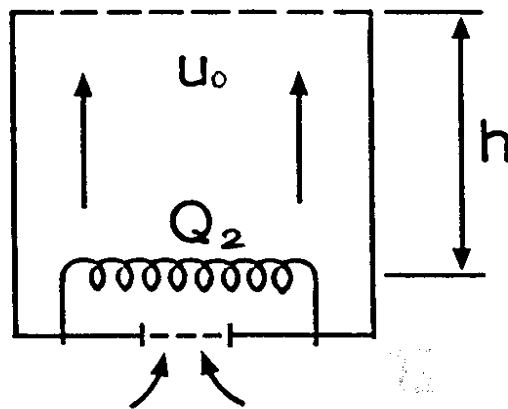

Fig. 1. Ventilation model

3. Experiments

3.1 Experimental apparatus

The experimental casing measured 220 mm long \times 230 mm wide \times 310 mm high (Fig. 2). The plastic casing material was 10 mm thick and had a thermal conductivity of 0.01 W/(m K). A wire heater (2.3-mm gauge) was placed inside (Fig. 3). The size, location, and grille patterning of a rectangular vent on one of the side walls were varied (Fig. 4). Experiments

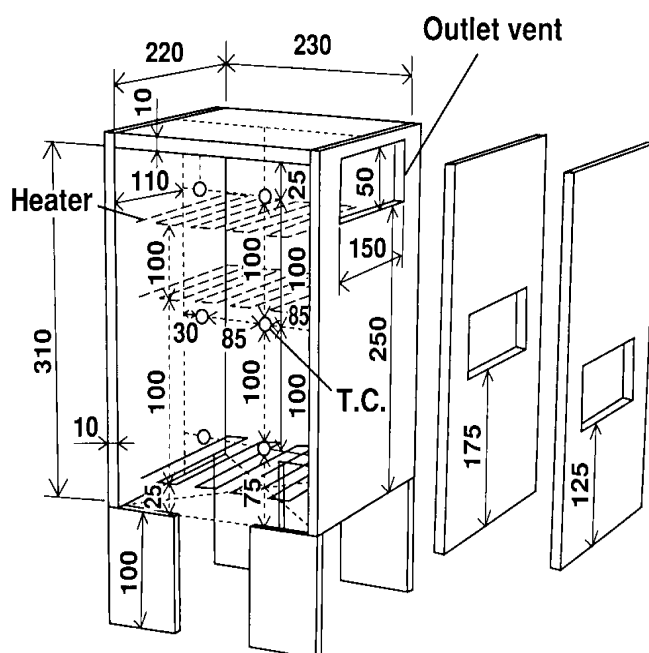

Fig. 2. Experimental casing

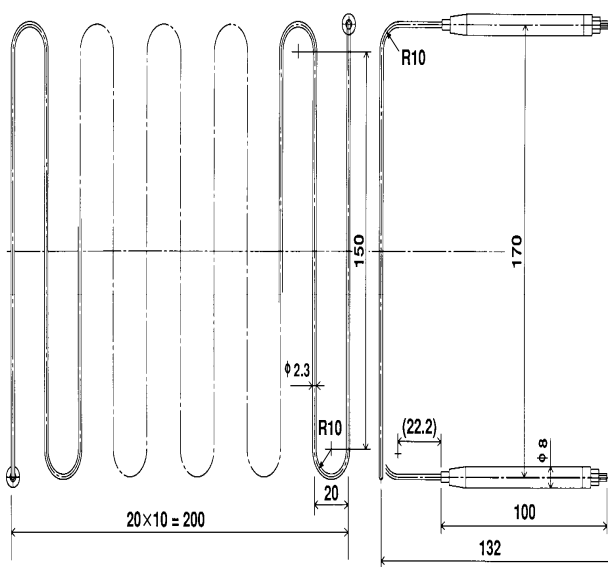
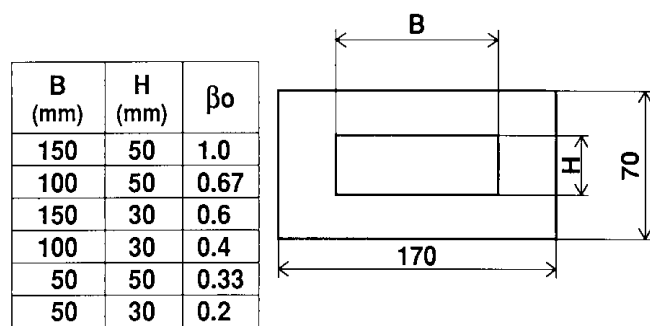

Fig. 3. Heater construction

were performed for three distances between the wall base and the center of the outlet vent ($H_v = 275, 200,$ and 150 mm) and for three heights of the heater above the base ($H_h = 25, 125,$ and 225 mm), with the heater always placed below the outlet vent. The cooling air entered through an opening in the center of the casing base (150 mm \times 130 mm) and was exhausted through the upper outlet. The air temperature distribution inside the casing, the room temperature, and the wall temperatures were measured by calibrated K-type thermocouples (± 0.1 K, 0.1 mm in diameter). The thermocouples inside the casing were arranged $30, 85,$ and 115 mm from the inside of the left side wall at each of $75, 175,$ and 275 mm above the base (Fig. 2). On the walls, thermocouples were placed at the center of

the top surface and at three locations down the center line of each side wall, and one thermocouple was placed outside the casing to measure the room temperature. The mean inner air temperature rise, ΔT_m , was calculated from the locally measured values over the whole volume of the casing.



(a) Opening pattern

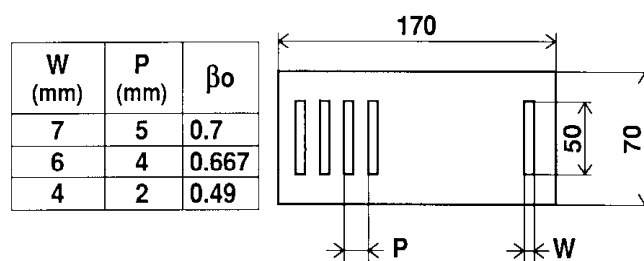

(b) Grille pattern

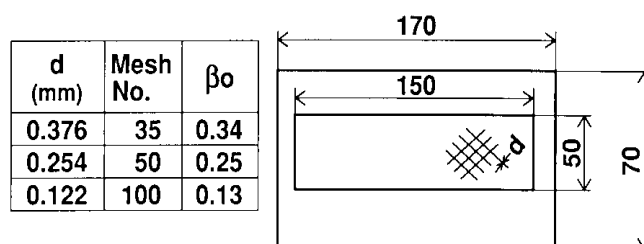

$$\beta_o = \text{Open area} / 150 \times 50$$

(c) Mesh pattern

Fig. 4. Outlet vent openings

3.2 Estimation of heat removed from casing surfaces

The amount of heat removed from the casing surfaces was estimated by experiment. For this purpose, the casing was considered to be a closed unit with no vents except at the base. Using the natural convective heat transfer equations for individual surfaces presented by Ishizuka et al. (1986), we expressed the amount of heat removed from the casing surfaces, Q_s , as:

$$Q_s = D_1 \Delta T_m^{1.25} \quad (6)$$

Eq. (6) shows the first term on the right-hand side of Eq. (1). Where, D_1 is the constant coefficient. The coefficient D_1 includes a radiative heat transfer factor and determined by the experiment. The amount of heat generation was within the $Q_s = 6\text{--}40$ W range (Fig. 5) when the room temperature T_a was 298 K. The results are shown in Fig.5 and are well expressed by Eq.(7).

$$Q_s = 0.445 \Delta T_m^{1.25} \quad (7)$$

where D_1 was determined to be 0.445. The temperature distribution in the casing was relatively uniform, within $\pm 5\%$. Hereafter, the amount of heat removed from the outlet vent, Q_v , was calculated as:

$$Q_v = Q - Q_s \quad (8)$$

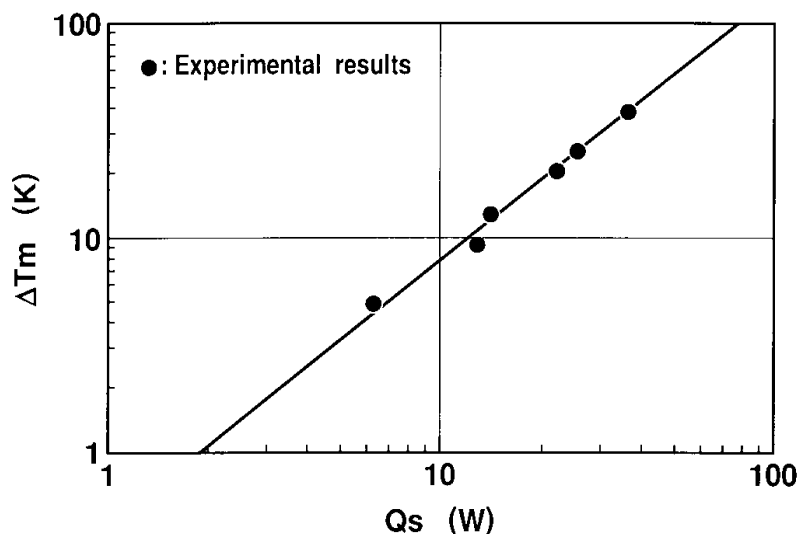

Fig. 5. Relationship between Q_s and ΔT_m

3.3 Influence of outlet vent size on temperature rise in the casing

The experiment was carried out by varying the outlet vent size of the reference casing at outlet vent position $H_v = 275$ mm and heater position at $H_h = 25$ mm (Fig. 2). The porosity coefficient β_o (Fig. 4) was defined as the ratio of the open area of each individual vent to the area of the reference vent (150 mm \times 50 mm).

At each value of input power, Q , as β_o decreased, ΔT_m increased linearly on the logarithmic plot (Fig. 6). As Q increased, ΔT_m also increased.

3.4 Influence of outlet vent position on mean temperature rise in the casing

The relationship between ΔT_m and outlet vent position H was investigated at two opening sizes with the heater at the bottom. ΔT_m decreased as H increased at both opening sizes (Fig. 7). It decreased faster at lower H .

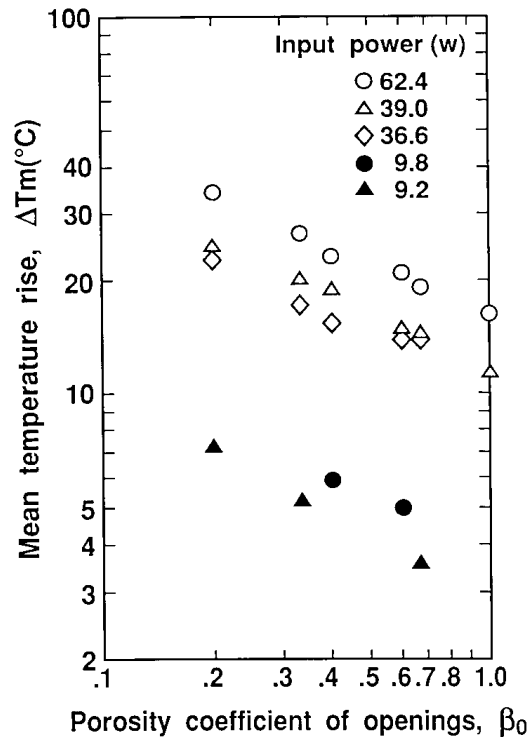

Fig. 6. Influence of vent porosity and input power on mean temperature rise in the casing

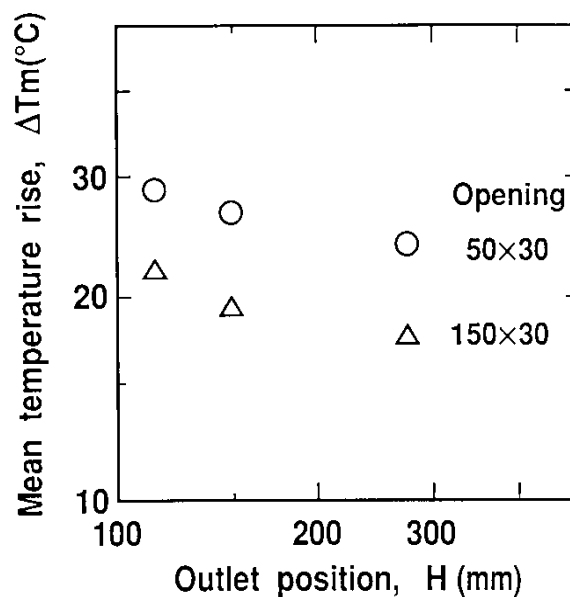

Fig. 7. Influence of outlet vent position on mean temperature rise in the casing

3.5 Influence of distance between outlet vent position and heater position on mean temperature rise in the casing

The relationship between ΔT_m (average of temperatures measured only above the heater position) and the distance between the outlet vent position and the heater position, h , was investigated by varying opening size and input power while the outlet height was fixed at $H_v = 275$ mm. As h increased, ΔT_m decreased at all values of input power (Fig. 8).

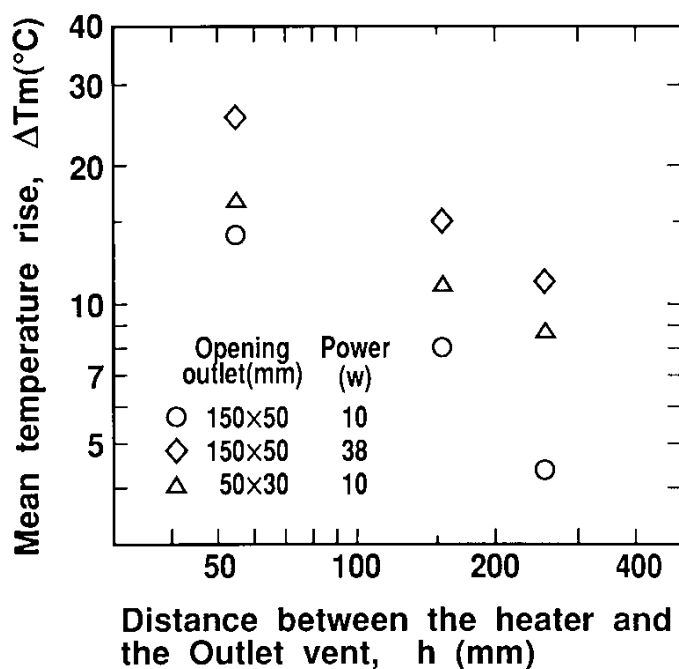

Fig. 8. Influence of distance between outlet vent position and heater position on mean temperature rise in the casing

4. Correlations using non-dimensional parameters

4.1 Flow resistance coefficient K

The flow resistance coefficient K was related to Q_v and h . If we assume a uniform temperature distribution and a one-dimensional steady-state flow in a ventilation model as shown in Fig. 1, we can express Eq. (9) for the overall energy balance and Eq. (10) for the balance between flow resistance and buoyancy force:

$$Q_v = \rho c_p A u \Delta T \tag{9}$$

$$(\rho_a - \rho) g h = K \rho u^2 / 2 \tag{10}$$

where Q_v is dissipated power, c_p is specific heat of the air at constant pressure, A is the cross-sectional area of the duct, u is airflow velocity, ΔT is temperature rise, ρ is air density (ρ_a is atmospheric condition), g is acceleration due to gravity, h is the distance between the outlet and the heater, and K is the flow resistance coefficient for the system. Since the pressure change in the system is small, the expression can be rewritten to assume a perfect gas:

$$(\rho_a - \rho) / \rho = (T - T_a) / T_a \tag{11}$$

K is defined in terms of hand Q_v as:

$$K = 2g h \Delta T^3 / (T_a (\rho c_p A / Q_v)^2) \tag{12}$$

In this study, H value was used in spite of h to arrange the present data.

4.2 Porosity coefficient

Generally, β_o is defined as the ratio of the area of the opening to the reference opening (Fig. 4). Here, as the top surface area is an ideal outlet vent area for a casing cooled by natural convection, we defined the porosity coefficient β as:

$$\beta = \text{open area in outlet vent} / \text{inner casing top surface area} \quad (13)$$

4.3 Reynolds number Re

The velocity u was obtained using Eq. (9) and the hydrodynamic equivalent diameter of an opening with height A and width B was used as a reference length:

$$L = 4AB / 2(A+B) \quad (14)$$

Thus, Re is defined as:

$$Re = uL / \nu \quad (15)$$

4.4 Relationship among K , Re , and β

Re was multiplied by the term $\beta^2 / (1-\beta)^2$ to give X for correlation with K , as for wire nets and perforated plates reported by Ishizuka et al. (1986):

$$X = Re(\beta^2 / (1-\beta)^2) \quad (16)$$

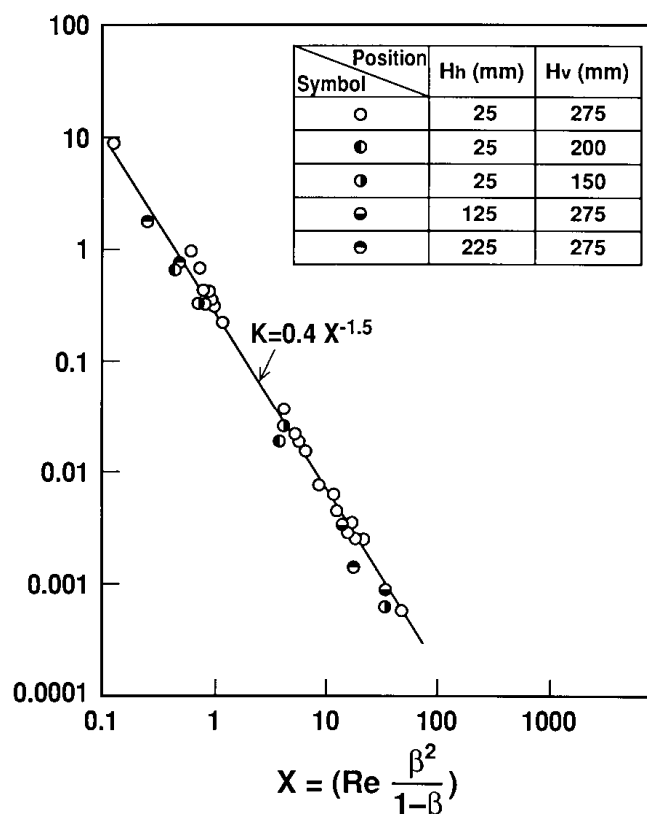

Fig. 9. Relationship among K , Re and β

This multiplier has previously been used for higher values of Re , for example, in the case of forced air convection (Collar 1939). In the empirical correlation of K with X , all the K values obtained under the reference condition (outlet vent in the upper position and heater at the bottom) lie on the line, but others lie slightly below the line (Fig. 9). The reason for this discrepancy is likely to be measurement uncertainty, due to:

1. errors in the estimation of mean temperature rise from the temperature measured at the flow location
2. errors in the estimation of the amount of heat removed from the casing surface
3. the method of estimating the mean temperature rise when the heater position was varied.

The best-fit line was:

$$K=0.4X^{-1.5} \quad (17)$$

where the coefficient of 0.4 is inherent in this apparatus and is not a general value. This fit indicates that h can be considered as chimney height in practical equipment as well, and that the definition of β is reasonable. A more detailed discussion requires 3-dimensional thermo-fluid analysis and more precise measurement. However, we consider that a useful relationship among K , Re , and β can be determined from a practical point of view.

5. Conclusion

Experimental analysis of the effects of the size of the outlet vent opening and the distance between the outlet vent and the heater location on the flow resistance in a natural-air-cooled electronic equipment case revealed the following relationship among the flow resistance coefficient K , Reynolds number Re , and the outlet vent porosity coefficient β (defined on the basis of the top surface area):

$$K = BX^{-1.5}$$

where $X = Re(\beta^2/(1 - \beta))$ and B is an inherent coefficient of the casing in question.

6. References

- Bergles, A. E., 1990, *Heat Transfer in Electronic and Microelectronic Equipment*, Hemisphere, New York.
- Collar, A. R., 1939, The effect of a gauze on the velocity distribution in a uniform duct, *Brit. Aero. Res. Coun., Rep. Mem.* 1867.
- Guglielmini, D., Milano, G., and Misale M., 1988, "Natural air cooling of electronic cards in ventilated enclosures," *Second UK National Conference on Heat Transfer*, Vol. I, pp. 199-210.
- Ishizuka, M., Miyazaki, Y., and Sasaki, T., 1986, On the cooling of natural air cooled electronic equipment casings, *Bull. JSME*, Vol. 29, No. 247, pp. 119-123.
- Ishizuka, M., Miyazaki, Y. and Sasaki, T., 1987, Air resistance coefficients for perforated plates in free convection, *A SME J Heat Transfer*, Vol. 109, pp. 540-543.
- Ishizuka, M., 1995, A Thermal Design Approach for Natural Air Cooled Electronic Equipment Casings, ASME-HTD-Vol.303, National Heat Transfer Conference, Portland, USA, pp.65-72.

Wenxian Lin , S.W. Armfield, Natural convection cooling of rectangular and cylindrical containers, *International Journal of Heat and Fluid Flow*, 22 (2001) 72–81

IntechOpen

IntechOpen



Heat Transfer - Engineering Applications

Edited by Prof. Vyacheslav Vikhrenko

ISBN 978-953-307-361-3

Hard cover, 400 pages

Publisher InTech

Published online 22, December, 2011

Published in print edition December, 2011

Heat transfer is involved in numerous industrial technologies. This interdisciplinary book comprises 16 chapters dealing with combined action of heat transfer and concomitant processes. Five chapters of its first section discuss heat effects due to laser, ion and plasma-solid interaction. In eight chapters of the second section engineering applications of heat conduction equations to the curing reaction kinetics in manufacturing process, their combination with mass transport or ohmic and dielectric losses, heat conduction in metallic porous media and power cables are considered. Analysis of the safety of mine hoist under influence of heat produced by mechanical friction, heat transfer in boilers and internal combustion engine chambers, management for ultrahigh strength steel manufacturing are described in this section as well. Three chapters of the last third section are devoted to air cooling of electronic devices.

How to reference

In order to correctly reference this scholarly work, feel free to copy and paste the following:

Masaru Ishizuka and Tomoyuki Hatakeyama (2011). Design of Electronic Equipment Casings for Natural Air Cooling: Effects of Height and Size of Outlet Vent on Flow Resistance, Heat Transfer - Engineering Applications, Prof. Vyacheslav Vikhrenko (Ed.), ISBN: 978-953-307-361-3, InTech, Available from: <http://www.intechopen.com/books/heat-transfer-engineering-applications/design-of-electronic-equipment-casings-for-natural-air-cooling-effects-of-height-and-size-of-outlet->

INTECH
open science | open minds

InTech Europe

University Campus STeP Ri
Slavka Krautzeka 83/A
51000 Rijeka, Croatia
Phone: +385 (51) 770 447
Fax: +385 (51) 686 166
www.intechopen.com

InTech China

Unit 405, Office Block, Hotel Equatorial Shanghai
No.65, Yan An Road (West), Shanghai, 200040, China
中国上海市延安西路65号上海国际贵都大饭店办公楼405单元
Phone: +86-21-62489820
Fax: +86-21-62489821

© 2011 The Author(s). Licensee IntechOpen. This is an open access article distributed under the terms of the [Creative Commons Attribution 3.0 License](#), which permits unrestricted use, distribution, and reproduction in any medium, provided the original work is properly cited.

IntechOpen

IntechOpen