

# We are IntechOpen, the world's leading publisher of Open Access books Built by scientists, for scientists

5,200

Open access books available

129,000

International authors and editors

150M

Downloads

Our authors are among the

154

Countries delivered to

TOP 1%

most cited scientists

12.2%

Contributors from top 500 universities



WEB OF SCIENCE™

Selection of our books indexed in the Book Citation Index  
in Web of Science™ Core Collection (BKCI)

Interested in publishing with us?  
Contact [book.department@intechopen.com](mailto:book.department@intechopen.com)

Numbers displayed above are based on latest data collected.  
For more information visit [www.intechopen.com](http://www.intechopen.com)



## Non-Adaptive Sliding Mode Controllers in Terms of Inertial Quasi-Velocities

Przemyslaw Herman and Krzysztof Kozlowski  
*Poznan University of Technology  
Poland*

### 1. Introduction

Trajectory control problem arises if the manipulator is required to follow a desired trajectory. In the robotic literature mainly two approaches are used: computer torque (inverse dynamic control) and sliding mode control Sciavicco & Siciliano (1996); Slotine & Li (1991). The system under inverse dynamics controller is linear and decoupled with respect to the newly obtained input. In robotics literature very popular is the sliding mode method described by Slotine & Li (1987; 1991). The approach differs from the previous one because even if the parameters are exactly known, the manipulator equations of motion are not linearized by the control law. The sliding mode control strategies are used in the manipulator joint space as well as in its operational space Sciavicco & Siciliano (1996); Slotine & Li (1987; 1991). From the practical point of view to track the position of the end-effector of the manipulator is more convenient than the joint position tracking because the task is realized directly. The motion control problem in the manipulator joint space and the operational space is investigated also in newer references Kelly & Moreno (2005); Moreno & Kelly (2003); Moreno et al. (2003); Moreno-Valenzuela & Kelly (2006). Sometimes also a friction model is taken into account, e.g. Moreno et al. (2003); Moreno-Valenzuela & Kelly (2006). One of known applications of the sliding mode approach allows one to control a shape Mochiyama et al. (1999). In order to design various versions of control laws strict Lyapunov functions for a class of global regulators for robot manipulators are introduced Santibanez & Kelly (1997); Spong (1992) or in terms of the IQV also in Herman (2009b).

Classical description leads to obtaining second-order nonlinear differential equations of motion. The equations involve both generalized position vector and velocity vector which represent a joint space of the manipulator. However, for control purposes first-order equations of motion with diagonal mass matrix seem more convenient than the second-order equations. It is possible to consider the dynamics of mechanical systems using quasi-velocities and differential geometry Kwatny & Blankenship (2000). The obtained first-order equations of motion are the Poincaré's form of the Lagrange's equations. One of useful solutions which leads to the diagonal or the unit inertia matrix is introducing so called inertial quasi-velocities (IQV). There exist several methods which enable such decomposition (e.g. Hurtado (2004); Jain & Rodriguez (1995); Junkins & Schaub (1997); Loduha & Ravani (1995); Sovinsky et al. (2005)). The method presented in Hurtado (2004) is associated with the Cholesky decomposition Sovinsky et al. (2005). In the method described by Jain & Rodriguez (1995) the normalized quasi-velocities (NQV) and the unnormalized quasi-velocities (UQV) were introduced. The

next method Junkins & Schaub (1997) is based on the eigenvalues and eigenvectors calculation of the inertia matrix. The Loduha and Ravani offer the generalized velocity components (GVC) which can be related to the modified Kane's equations given e.g. in Kane & Levinson (1983). Finally, also the normalized generalized velocity components (NGVC) are considered in references Herman (2005b; 2006). The NGVC are a useful form of the GVC.

The key idea of the paper is a survey of selected non-adaptive sliding mode controllers expressed in terms of the inertial quasi-velocities (IQV). The IQV mean that the quasi-velocities contain the kinematic and dynamic parameters of a rigid manipulator as well as its geometrical dimensions. In spite that there exist several IQV, only some of them are considered here, namely: the GVC described in Loduha & Ravani (1995), the NQV given in Jain & Rodriguez (1995), and the NGVC presented in Herman (2005b; 2006). It is because these kind of IQV very well explain the idea of non-adaptive sliding mode control in terms of the quasi-velocities. The second aim is to point at some advantages which offers the sliding mode control scheme in using the IQV. It is also shown which benefits are observable if the system under the proposed control law is considered. One of advantages arises from the fact that the IQV are decoupled in the kinetic energy sense and they lead to decoupling of the inertia matrix of the manipulator. Consequently, the inertia which takes into account also dynamical coupling can be determined. Moreover, some disadvantages of the IQV control approach are indicated. The third objective is to show that the sliding mode controllers are realized both in the manipulator joint space and the operational space. Additionally, it is possible to take into consideration disturbances (here represented by a viscous damping function) which, in prospect, it allows one to extend the results for use of various friction models.

The paper is organized as follows. Section 2 gives diagonalized equations of motion in terms of the IQV. In Section 3 the sliding mode controllers in the joint space of a manipulator as well as in its operational space are presented. Simulation results comparing performance between the new control schemes and the classical controllers for two models of rigid serial manipulator, namely 3 D.O.F. spatial DDArm robot and Yasukawa-like robot are contained in Section 4. The last section offers conclusions and future research.

## 2. Dynamics in terms of inertial quasi-velocities

### 2.1 Notation

$\theta, \dot{\theta}, \ddot{\theta} \in R^{\mathcal{N}}$  - vectors of generalized positions, velocities, and accelerations, respectively,

$\mathcal{N}$  - number of degrees of freedom,

$M(\theta) \in R^{\mathcal{N} \times \mathcal{N}}$  - system inertia matrix,

$C(\theta, \dot{\theta}) \in R^{\mathcal{N}}$  - vector of Coriolis and centrifugal forces in classical equations of motion,

$G(\theta) \in R^{\mathcal{N}}$  - vector of gravitational forces in classical equations of motion,

$f(\dot{\theta}) = F\dot{\theta} \in R^{\mathcal{N}}$  - vector of forces due to friction (viscous damping) which depends on the joint velocity vector  $\dot{\theta}$  where  $F = \text{diag}\{F_1, \dots, F_{\mathcal{N}}\}$  is a positive definite diagonal matrix containing the damping coefficients for all joints,

$Q \in R^{\mathcal{N}}$  - vector of generalized forces,

$N \in R^{\mathcal{N} \times \mathcal{N}}$  - diagonal system inertia matrix in terms of the GVC,

$u, \dot{u} \in R^{\mathcal{N}}$  - vector of generalized velocity components and its time derivative, respectively,

$Y = Y(\theta) \in R^{\mathcal{N} \times \mathcal{N}}$  - upper triangular transformation matrix between the velocity vector  $\dot{\theta}$  and the generalized velocity components vector  $u$  Loduha & Ravani (1995),

$\dot{Y}(\theta) \in R^{\mathcal{N} \times \mathcal{N}}$  - time derivative of the matrix  $Y(\theta)$ ,

$C_u(\theta, u) \in R^{\mathcal{N}}$  - vector of Coriolis and centrifugal forces in terms of the GVC,

$G_u(\theta) \in R^{\mathcal{N}}$  - vector of gravitational forces in terms of the GVC,

$f_u(\theta, \dot{\theta}) \in R^N$  - vector of friction damping forces in terms of the GVC,  
 $\pi \in R^N$  - vector of quasi-forces in terms of the GVC,  
 $\vartheta, \dot{\vartheta} \in R^N$  - vector of quasi-velocities, i.e. the NGVC and its time derivative, respectively,  
 $\Phi = \Phi(\theta) \in R^{N \times N}$  - upper triangular velocity transformation matrix in terms of the NGVC,  
 $\dot{\Phi}(\theta) \in R^{N \times N}$  - time derivative of the matrix  $\Phi(\theta)$ ,  
 $C_\vartheta(\theta, \vartheta) \vartheta \in R^N$  - vector of Coriolis and centrifugal forces in terms of the NGVC,  
 $G_\vartheta(\theta) \in R^N$  - vector of gravitational forces in terms of the NGVC,  
 $f_\vartheta(\theta, \dot{\theta}) \in R^N$  - vector of friction damping forces in terms of the NGVC,  
 $\omega \in R^N$  - vector of quasi-forces in terms of NGVC,  
 $v \in R^N$  vector of normalized quasi-velocities,  
 $C_v(\theta, v) v \in R^N$  vector of Coriolis and centrifugal forces in the NQV,  
 $G_v(\theta) \in R^N$  vector of gravitational forces in the NQV,  
 $m = m(\theta) \in R^{N \times N}$  spatial operator (matrix) - "square root" of the inertia matrix  $M(\theta)$ ,  
 $\dot{m}(\theta) \in R^{N \times N}$  time derivative of the matrix  $m(\theta)$ ,  
 $\epsilon \in R^N$  vector of normalized quasi-forces (in terms of the NQV),  
 $D \in R^{N \times N}$  articulated inertia about joint axes matrix Jain & Rodriguez (1995),  
 $(.)^T$  - transpose operation.

## 2.2 Equations of motion

Recall that the classical equations of motion for a manipulator can be written in the following form Sciavicco & Siciliano (1996); Slotine & Li (1987; 1991):

$$M(\theta)\ddot{\theta} + C(\theta, \dot{\theta})\dot{\theta} + G(\theta) = Q. \quad (1)$$

In terms of the IQV the equations of motion depend on the used decomposition of the inertia matrix  $M(\theta)$ . The first of here considered decomposition methods is based on the generalized velocity components (GVC) Loduha & Ravani (1995). In this method  $M(\theta) = Y^{-T}NY^{-1}$ . The equations were proposed by Loduha & Ravani (1995).

$$N\dot{u} + C_u(\theta, u)u + G_u(\theta) = \pi, \quad (2)$$

$$\dot{\theta} = Y(\theta)u, \quad (3)$$

where matrices and vectors are given as follows:

$$N = Y^T M(\theta) Y, \quad \dot{u} = Y^{-1}\ddot{\theta} + \dot{Y}^{-1}\dot{\theta}, \quad (4)$$

$$C_u(\theta, u) = Y^T [M(\theta)\dot{Y} + C(\theta, \dot{\theta})Y], \quad (5)$$

$$G_u(\theta) = Y^T G(\theta), \quad (6)$$

$$\pi = Y^T Q. \quad (7)$$

Equations (2) and (3) provide a closed set of first-order differential equations for manipulator in terms of GVC.

In the second considered method assuming the inertia matrix decomposition method given in Jain & Rodriguez (1995), which leads to the NQV and with  $M(\theta) = mm^T$ , we obtain the following equations of motion:

$$\dot{v} + C_v(\theta, v)v + G_v(\theta) = \epsilon, \quad (8)$$

$$v = m^T(\theta)\dot{\theta}, \quad (9)$$

where

$$\dot{v} = \dot{m}^T(\theta)\dot{\theta} + m^T(\theta)\ddot{\theta}, \quad (10)$$

$$C_v(\theta, v) = [m^{-1}(\theta)C_v(\theta, \dot{\theta}) - \dot{m}^T(\theta)](m^{-1}(\theta))^T, \quad (11)$$

$$G_v(\theta) = m^{-1}(\theta)G(\theta), \quad (12)$$

$$\epsilon = m^{-1}(\theta)Q. \quad (13)$$

As results from Jain & Rodriguez (1995) we have also the relationship

$$v^T C_v(\theta, v) v = 0. \quad (14)$$

However, we can prove this property. The time derivative of the mass matrix is  $\dot{M} = \dot{m}m^T + m\dot{m}^T$ . Using (9), (11), and taking into account the above assumption one can calculate:

$$\begin{aligned} v^T C_v(\theta, v) v &= v^T [m^{-1}C_v(\theta, \dot{\theta}) - \dot{m}^T](m^T)^{-1}v = \dot{\theta}^T C_v(\theta, \dot{\theta})\dot{\theta} - \dot{\theta}^T m\dot{m}^T\dot{\theta} = \dot{\theta}^T \frac{1}{2}\dot{M}\dot{\theta} \\ -\dot{\theta}^T m\dot{m}^T\dot{\theta} &= \dot{\theta}^T \left[ \frac{1}{2}(\dot{m}m^T - m\dot{m}^T) \right] \dot{\theta} = v^T \frac{1}{2}m^{-1}(\dot{m}m^T - m\dot{m}^T)(m^{-1})^T v = 0, \end{aligned} \quad (15)$$

because the matrix  $(\dot{m}m^T - m\dot{m}^T)$  is a skew symmetric one. From the above derivation arises that  $C_v(\theta, v) = \frac{1}{2}m^{-1}(\dot{m}m^T - m\dot{m}^T)(m^{-1})^T$ .

The third decomposition method Herman (2005b; 2006) is an extension of the method Loduha & Ravani (1995) and it is based on the NGVC with  $M(\theta) = \Phi^T \Phi$ . Hence the two first-order equations (the diagonalized equation of motion and the velocity transformation equation) for rigid manipulator can be rewritten in the form:

$$\dot{\vartheta} + C_\vartheta(\theta, \vartheta)\vartheta + G_\vartheta(\theta) = \omega, \quad (16)$$

$$\vartheta = \Phi(\theta)\dot{\theta}, \quad (17)$$

where

$$\dot{\vartheta} = \Phi\ddot{\theta} + \dot{\Phi}\dot{\theta}, \quad \Phi = N^{\frac{1}{2}}Y^{-1}, \quad (18)$$

$$C_\vartheta(\theta, \vartheta) = [(\Phi^T)^{-1}C(\theta, \dot{\theta}) - \dot{\Phi}]\Phi^{-1}, \quad (19)$$

$$G_\vartheta(\theta) = (\Phi^T)^{-1}G(\theta), \quad (20)$$

$$\omega = (\Phi^T)^{-1}Q. \quad (21)$$

*Remark 1.* If the viscous damping forces are taken into account then we have the following classical equations of motion, and e.g. the equations in terms of the GVC and the NGVC:

$$M(\theta)\ddot{\theta} + C(\theta, \dot{\theta})\dot{\theta} + G(\theta) + f(\dot{\theta}) = Q, \quad (22)$$

$$N\dot{u} + C_u(\theta, u)u + G_u(\theta) + f_u(\theta, \dot{\theta}) = \pi, \quad (23)$$

$$\dot{\vartheta} + C_\vartheta(\theta, \vartheta)\vartheta + G_\vartheta(\theta) + f_\vartheta(\theta, \dot{\theta}) = \omega, \quad (24)$$

where  $f_u(\theta, \dot{\theta}) = Y^T f(\dot{\theta})$  and  $f_\vartheta(\theta, \dot{\theta}) = (\Phi^T)^{-1} f(\dot{\theta})$ .

### 2.3 Other decomposition methods

The main problem concerning the transformed equations of motion is the selection method for decomposition of the inertia matrix. There are various known methods for decomposition of the inertia matrix to obtain a diagonal matrix or the identity matrix. For this purpose the Cholesky factorization (which can be referred to Hurtado (2004); Matlab (1996); Sovinsky et al. (2005) or decomposition into the eigenvalues and the eigenvectors considered in Junkins & Schaub (1997); Matlab (1996). Moreover, using e.g. the Schur decomposition or the singular value decomposition Matlab (1996) we are able to decompose the inertia matrix. The eigenvalue and eigenvector based decomposition method, the Schur decomposition method and the singular value decomposition method for a symmetric and positive definite matrix  $M$  lead to obtaining a transformation matrix which has, in general, all nonzero elements. This fact complicates a possible controller design because the number of necessary numerical operation increase and each variable. However, sometimes the use of the appropriate method (not very much time consuming) may decide about performance of a non-adaptive sliding mode controller.

### 2.4 Some useful properties of IQV

Some advantages arising from the description of motion in terms of the IQV concern an insight into the manipulator dynamics. The kinetic energy of the manipulator is expressed as (compare Herman (2005a), Jain & Rodriguez (1995), and Herman (2005b), respectively):

$$K(\theta, u) = \frac{1}{2} \dot{\theta}^T M(\theta) \dot{\theta} = \frac{1}{2} u^T N u = \frac{1}{2} \sum_{k=1}^{\mathcal{N}} N_k u_k^2 = \sum_{k=1}^{\mathcal{N}} K_k, \quad (25)$$

$$K(\theta, v) = \frac{1}{2} \dot{\theta}^T M(\theta) \dot{\theta} = \frac{1}{2} \dot{\theta}^T m(\theta) m^T(\theta) \dot{\theta} = \frac{1}{2} v^T v = \frac{1}{2} \sum_{k=1}^{\mathcal{N}} v_k^2 = \sum_{k=1}^{\mathcal{N}} K_k, \quad (26)$$

$$K(\theta, \vartheta) = \frac{1}{2} \dot{\theta}^T M(\theta) \dot{\theta} = \frac{1}{2} \dot{\theta}^T \Phi^T \Phi \dot{\theta} = \frac{1}{2} \vartheta^T \vartheta = \frac{1}{2} \sum_{k=1}^{\mathcal{N}} \vartheta_k^2 = \sum_{k=1}^{\mathcal{N}} K_k. \quad (27)$$

The above given formulas allow one to determine the part of energy corresponding to each inertial quasi-velocity individually (and also concerning the appropriate link taking into account the dynamical coupling).

Additionally, it is possible to calculate elements of the matrix  $N$  (GVC and NGVC) or  $D$  (NQV) - see *Notation* - which can be understood as a rotational inertia about each joint axis or a mass shifted along the translational joint. Using the equation (1) this information is inaccessible.

## 3. Sliding mode controllers using inertial quasi-velocities

### 3.1 Control algorithms in joint space

In classical form the sliding mode controller in joint space of a manipulator can be expressed as follows Sciavicco & Siciliano (1996); Slotine & Li (1991):

$$Q = M(\theta) \ddot{\theta}_r + C(\theta, \dot{\theta}) \dot{\theta}_r + G(\theta) + k_D s. \quad (28)$$

The used symbols denote:  $\ddot{\theta}_r = \ddot{\theta}_d + \Lambda \dot{\tilde{\theta}}$ ,  $\dot{\theta}_r = \dot{\theta}_d + \Lambda \tilde{\theta}$  with  $\ddot{\theta}_d$  as the desired joint acceleration vector and  $\tilde{\theta} = \theta_d - \theta$ ,  $\dot{\tilde{\theta}} = \dot{\theta}_d - \dot{\theta}$  the joint velocities error, and the joint error between the desired and actual posture, respectively. The matrix  $\Lambda$  is constant and it has eigenvalues

strictly in the right-half complex plane and  $k_D$  is a constant positive definite control gain matrix. The vector  $s$  is defined as  $s = \dot{\tilde{\theta}} + \Lambda\tilde{\theta}$ .

In terms of the GVC introduced originally by Loduha & Ravani (1995) the non-adaptive sliding mode controller can be presented in the given below proposition. Recall also that from (3) arises the relationship  $u = Y^{-1}\dot{\theta}$  (the matrix  $Y$  is invertible) and the time derivative of  $\dot{\theta} = Yu$  is  $\ddot{\theta} = \dot{Y}u + Y\dot{u}$ . It is assumed the following sliding surface of the objective point

$$Y^{-1}(\dot{\tilde{\theta}} + \Lambda\tilde{\theta}) = 0. \quad (29)$$

**Proposition 1.** Consider the system (2) and (3) together with the controller in terms of the GVC Herman (2005a)

$$\pi = N\dot{u}_r + C(\theta, u)u_r + G_u(\theta) + k_D s_u + Y^T k_P \tilde{\theta}, \quad (30)$$

where

$$u_r = Y^{-1}\dot{\theta}_r, \quad \dot{u}_r = Y^{-1}(\ddot{\theta}_r - \dot{Y}u_r), \quad (31)$$

$$s_u = u_r - u = Y^{-1}(\dot{\tilde{\theta}} + \Lambda\tilde{\theta}), \quad (32)$$

with positive definite  $k_D, k_P, \Lambda$  control gain matrices, and  $\ddot{\theta}_r = \ddot{\theta}_d + \Lambda\dot{\tilde{\theta}}, \dot{\theta}_r = \dot{\theta}_d + \Lambda\tilde{\theta}, \tilde{\theta} = \theta_d - \theta, \dot{\tilde{\theta}} = \dot{\theta}_d - \dot{\theta}$ . Using the definition (29) and if the signals  $\dot{\theta}_d, \ddot{\theta}_d, \tilde{\theta}_d$  are bounded, then the equilibrium point  $[s_u^T, \tilde{\theta}^T]^T = 0$  is globally asymptotically stable in the sense of Lyapunov. The joint forces (which arises from (7)) are given as  $Q = (Y^T)^{-1}\pi$ .

**Proof** Herman (2005a). The closed loop system with control (30) using  $s_u$  is given as follows

$$N\dot{u} + C(\theta, u)u + G_u(\theta) = N\dot{u}_r + C(\theta, u)u_r + G_u(\theta) + k_D s_u + Y^T k_P \tilde{\theta}, \quad (33)$$

what leads to

$$N\dot{s}_u + [C(\theta, u) + k_D]s_u + Y^T k_P \tilde{\theta} = 0. \quad (34)$$

As a Lyapunov function candidate consider the following expression

$$\mathcal{L}(s_u, \tilde{\theta}) = \frac{1}{2}s_u^T N s_u + \frac{1}{2}\tilde{\theta}^T k_P \tilde{\theta}. \quad (35)$$

The time derivative of  $N$  equals (where  $M = M(\theta)$ )

$$\dot{N} = \frac{d}{dt}(Y^T M Y) = \dot{Y}^T M Y + Y^T \dot{M} Y + Y^T M \dot{Y}. \quad (36)$$

Next we calculate the time derivative of (35), use (2)-(7), (34), (36), and the property, e.g. Kelly & Moreno (2005); Slotine & Li (1991)

$$q^T \left[ \frac{1}{2}\dot{M}(\theta) - C(\theta, \dot{\theta}) \right] q = 0, \quad \forall q, \theta, \dot{\theta} \in R^{\mathcal{N}}. \quad (37)$$

After transposition of (3) one can obtain ( $\dot{\mathcal{L}} = \frac{d\mathcal{L}}{dt}$ ):

$$\begin{aligned} \dot{\mathcal{L}}(s_u, \tilde{\theta}) &= s_u^T N \dot{s}_u + \frac{1}{2} s_u^T \dot{N} s_u + \dot{\tilde{\theta}}^T k_P \tilde{\theta} = s_u^T [-C(\theta, u) s_u - k_D s_u + \frac{1}{2} \dot{N} s_u] - s_u^T Y^T k_P \tilde{\theta} \\ &+ \dot{\tilde{\theta}}^T k_P \tilde{\theta} = s_u^T [-Y^T M \dot{Y} s_u - Y^T C(\theta, \dot{\theta}) Y s_u - k_D s_u + \frac{1}{2} (\dot{Y}^T M Y + Y^T \dot{M} Y \\ &+ Y^T M \dot{Y}) s_u] - s_u^T Y^T k_P \tilde{\theta} + \dot{\tilde{\theta}}^T k_P \tilde{\theta} = -s_u^T k_D s_u + s_u^T [\frac{1}{2} Y^T M \dot{Y} - Y^T M \dot{Y} + \frac{1}{2} \dot{Y}^T M Y \\ &+ Y^T (\frac{1}{2} \dot{M} - C(\theta, \dot{\theta})) Y] s_u - s_u^T Y^T k_P \tilde{\theta} + \dot{\tilde{\theta}}^T k_P \tilde{\theta} = -s_u^T k_D s_u + \frac{1}{2} s_u^T (\dot{Y}^T M Y - Y^T M \dot{Y}) s_u \\ &- s_u^T Y^T k_P \tilde{\theta} + \dot{\tilde{\theta}}^T k_P \tilde{\theta} = -s_u^T k_D s_u - s_u^T Y^T k_P \tilde{\theta} + \dot{\tilde{\theta}}^T k_P \tilde{\theta}. \end{aligned} \tag{38}$$

Using (32) one can write:

$$\dot{\mathcal{L}}(s_u, \tilde{\theta}) = -s_u^T k_D s_u - (\dot{\tilde{\theta}}^T + \tilde{\theta}^T \Lambda^T) k_P \tilde{\theta} + \dot{\tilde{\theta}}^T k_P \tilde{\theta} = -s_u^T k_D s_u - \tilde{\theta}^T \Lambda^T k_P \tilde{\theta}. \tag{39}$$

Assumption that  $k_P = k_D \Lambda$  leads to

$$\dot{\mathcal{L}}(s_u, \tilde{\theta}) = -s_u^T k_D s_u - \tilde{\theta}^T \Lambda^T k_D \Lambda \tilde{\theta}. \tag{40}$$

The time derivative  $\dot{\mathcal{L}}$  (40) is a negative semidefinite function. Invoking Lyapunov direct method Khalil (1996); Slotine & Li (1991) the above proof is completed. Therefore,  $[s_u^T, \tilde{\theta}^T]^T = 0$  is globally asymptotically stable in the sense of Lyapunov.

*Remark 2.* The control law (30) can be also simplified as follows:  $\pi = N \dot{u}_r + C(\theta, u) u_r + G_u(\theta) + k_D s_u$ . The proof, in such case, can be given basing on the Barbalat’s Lemma Slotine & Li (1991). However, the performance of the simplified control algorithm is worse than if the controller (30) is used because of absence the additional position error regulation term.

The analogous tracking control problem can be considered in terms of the NQV. Consider the following surface:

$$m^T (\dot{\tilde{\theta}} + \Lambda \tilde{\theta}) = 0, \tag{41}$$

which is also a sliding surface of the objective point (the matrix  $m^T$  is invertible Jain & Rodriguez (1995)).

**Proposition 2.** Consider the system (8) and (9) together with the controller in terms of the NQV

$$\epsilon = \dot{v}_r + C_v(\theta, v) v_r + G_v(\theta) + k_D s_v + m^{-1} k_P \tilde{\theta}, \tag{42}$$

where

$$v_r = m^T \dot{\theta}_r, \quad \dot{v}_r = m^T (\ddot{\theta}_r - (\dot{m}^T)^{-1} v_r), \tag{43}$$

$$s_v = v_r - v = m^T (\dot{\tilde{\theta}} + \Lambda \tilde{\theta}), \tag{44}$$

with positive definite  $k_D, k_P, \Lambda$  control gain matrices, and  $\ddot{\theta}_r = \ddot{\theta}_d + \Lambda \dot{\tilde{\theta}}, \dot{\theta}_r = \dot{\theta}_d + \Lambda \tilde{\theta}, \tilde{\theta} = \theta_d - \theta, \dot{\tilde{\theta}} = \dot{\theta}_d - \dot{\theta}$ . Using the definition (41) and if the signals  $\dot{\theta}_d, \ddot{\theta}_d, \tilde{\theta}_d$  are bounded, then the equilibrium point  $[s_v^T, \tilde{\theta}^T]^T = 0$  is globally asymptotically stable in the sense of Lyapunov. The input forces vector of manipulator  $Q = m \epsilon$  arises from (13).

**Proof.** The closed loop system with control (42) using  $s_v$  is given as follows:

$$\dot{v} + C_v(\theta, v) v + G_v(\theta) = \dot{v}_r + C_v(\theta, v) v_r + G_v(\theta) + k_D s_v + m^{-1} k_P \tilde{\theta}, \tag{45}$$



which, using (44), leads to equation:

$$\dot{s}_\nu + [C_\nu(\theta, \nu) + k_D]s_\nu + m^{-1}k_P\tilde{\theta} = 0. \quad (46)$$

As a Lyapunov function candidate consider the following expression:

$$\mathcal{L} = \frac{1}{2}s_\nu^T s_\nu + \frac{1}{2}\tilde{\theta}^T k_P \tilde{\theta}. \quad (47)$$

Next, calculating the time derivative of (47), using (46), definition (44) and property (14) one obtains:

$$\begin{aligned} \dot{\mathcal{L}} &= s_\nu^T \dot{s}_\nu + \tilde{\theta}^T k_P \dot{\tilde{\theta}} = s_\nu^T (-C_\nu(\theta, \nu)s_\nu - k_D s_\nu - m^{-1}k_P \tilde{\theta}) + \tilde{\theta}^T k_P \dot{\tilde{\theta}} \\ &= -s_\nu^T C_\nu(\theta, \nu)s_\nu - s_\nu^T k_D s_\nu - s_\nu^T m^{-1}k_P \tilde{\theta} + \tilde{\theta}^T k_P \dot{\tilde{\theta}} = -s_\nu^T k_D s_\nu - (\dot{\tilde{\theta}}^T + \tilde{\theta}^T \Lambda^T)k_P \tilde{\theta} \\ &\quad + \tilde{\theta}^T k_P \dot{\tilde{\theta}} = -s_\nu^T k_D s_\nu - \tilde{\theta}^T \Lambda^T k_P \tilde{\theta}. \end{aligned} \quad (48)$$

Choosing  $k_P = k_D \Lambda$  yields

$$\dot{\mathcal{L}} = -s_\nu^T k_D s_\nu - \tilde{\theta}^T \Lambda^T k_D \Lambda \tilde{\theta}. \quad (49)$$

One can observe that  $\dot{\mathcal{L}}$  (49) is a negative semidefinite function. Invoking Lyapunov direct method Khalil (1996); Slotine & Li (1991) the above proof is completed. Therefore,  $[s_\nu^T, \tilde{\theta}^T]^T = 0$  is globally asymptotically stable in the sense of Lyapunov.

### 3.2 Control algorithms in operational space

Consider the sliding mode controller in the workspace of a rigid serial manipulator if the viscous damping is taken into account. In classical case the controller related to (22) can be described as follows Sciavicco & Siciliano (1996); Slotine & Li (1987):

$$Q = M(\theta)\ddot{\theta}_r + C(\theta, \dot{\theta})\dot{\theta}_r + G(\theta) + F\dot{\theta}_r + k_D s \quad (50)$$

where in order to extend the joint space controller to task space it is necessary to introduce:

$$\dot{\theta}_r = J_A^{-1}(\theta) [\dot{x}_d + \Lambda(x_d - x)] \quad (51)$$

$$\ddot{\theta}_r = J_A^{-1}(\theta) \{[\ddot{x}_d + \Lambda(\dot{x}_d - \dot{x})] - \dot{J}_A \dot{\theta}_r\} \quad (52)$$

$$s = \dot{\theta}_r - \dot{\theta} = J_A^{-1}(\theta) [\dot{x}_d - J_A(\theta)\dot{\theta} + \Lambda(x_d - x)]. \quad (53)$$

In the above equations the  $x_d$ ,  $\dot{x}_d$  and  $\ddot{x}_d$  are the desired end-effector posture (position and orientation), velocity and acceleration, respectively. Moreover,  $x$  and  $\dot{x}$  denote actual end-effector posture and velocity whereas  $\theta_r$ ,  $\dot{\theta}_r$  and  $\ddot{\theta}_r$  are reference joint position, velocity and acceleration Slotine & Li (1987). The matrix  $k_D$  is positive definite whereas the matrix  $\Lambda$  is a diagonal (constant) matrix whose eigenvalues are strictly in the right-half complex plane. The used symbol  $J_A$  means the analytical Jacobian because the end-effector velocity can be defined by the kinematic relationship  $\dot{x} = J_A(\theta)\dot{\theta}$  Sciavicco & Siciliano (1996). In general  $J_A^{-1}(\theta)$  have to be replaced by the right pseudo-inverse of  $J_A$  i.e.  $J_A^\dagger = J_A^T (J_A J_A^T)^{-1}$ . Using the controller (50) the sliding surface

$$\dot{\tilde{x}} + \Lambda \tilde{x} = 0, \quad (54)$$

where  $\dot{\tilde{x}} = \dot{x}_d - \dot{x}$  and  $\tilde{x} = x_d - x$  is reached which in turn implies that  $\tilde{x} \rightarrow 0$  as  $t \rightarrow 0$ .

**Proposition 3** Herman (2009a). Consider the system (23) and (3) together with the controller in terms of the GVC

$$\pi = N\dot{u}_r + C_u(\theta, u)u_r + G_u(\theta) + Y^T F Y u_r + k_D s_u + J_{Au}^T(\theta) k_P \tilde{x}, \tag{55}$$

where

$$u_r = J_{Au}^{-1}(\theta) [\dot{x}_d + \Lambda(x_d - x)], \tag{56}$$

$$\dot{u}_r = J_{Au}^{-1}(\theta) \{ [\ddot{x}_d + \Lambda(\dot{x}_d - \dot{x})] - \dot{J}_{Au}(\theta) u_r \}, \tag{57}$$

$$s_u = u_r - u = J_{Au}^{-1}(\theta) [\dot{x}_d - J_{Au}(\theta) u + \Lambda(x_d - x)] = J_{Au}^{-1}(\theta) (\dot{\tilde{x}} + \Lambda \tilde{x}), \tag{58}$$

with positive definite  $k_D, k_P, \Lambda$  control gain matrices. Using the definition (54) (assuming that  $J_{Au}^{-1}(\theta)$  is a nonsingular matrix) and if the signals  $x_d, \dot{x}_d, \ddot{x}_d$  are bounded then the end-effector posture (position and orientation) error  $\tilde{x} = x_d - x$  and the velocity error  $\dot{\tilde{x}} = \dot{x}_d - \dot{x}$  are convergent to zero and the equilibrium point  $[s_u^T, \tilde{x}^T]^T = 0$  is globally exponentially stable. The joint forces (which arises from (7)) are given as  $Q = (Y^T)^{-1} \pi$ .

The end-effector velocity can be defined by  $\dot{x} = J_A(\theta) \dot{\theta}$  Sciavicco & Siciliano (1996) as well as by  $\dot{x} = J_{Au}(\theta) u$ . Comparing both relationships and taking into account (3) we conclude that  $J_{Au}(\theta) = J_A(\theta) Y$ . Besides, in general case instead of  $J_{Au}^{-1} = J_{Au}^{-1}(\theta)$  the right pseudo-inverse matrix  $J_{Au}^+ = J_{Au}^T (J_{Au} J_{Au}^T)^{-1}$  should be used. It is also assumed (basing on (3)) that  $\dot{\theta}_r = Y u_r$ .

**Proof** can be found in Herman (2009a).

In terms of the NGVC we propose the following nonlinear controller.

**Proposition 4** Herman (2009c). Consider a system (16) and (17) together with the controller

$$\omega = \dot{\vartheta}_r + C_\vartheta(\theta, \vartheta) \vartheta_r + G_\vartheta(\theta) + (\Phi^T)^{-1} F \Phi^{-1} \vartheta_r + k_D s_\vartheta + J_{A\vartheta}^T(\theta) k_P \tilde{x}, \tag{59}$$

where

$$\vartheta_r = J_{A\vartheta}^{-1}(\theta) [\dot{x}_d + \Lambda(x_d - x)], \tag{60}$$

$$\dot{\vartheta}_r = J_{A\vartheta}^{-1}(\theta) \{ [\ddot{x}_d + \Lambda(\dot{x}_d - \dot{x})] - \dot{J}_{A\vartheta}(\theta) \vartheta_r \}, \tag{61}$$

$$s_\vartheta = \vartheta_r - \vartheta = J_{A\vartheta}^{-1}(\theta) [\dot{x}_d - J_{A\vartheta}(\theta) \vartheta + \Lambda(x_d - x)] = J_{A\vartheta}^{-1}(\theta) (\dot{\tilde{x}} + \Lambda \tilde{x}), \tag{62}$$

with positive definite  $k_D, k_P, \Lambda$  control gain matrices. Using the definition (54) (assuming that  $J_{A\vartheta}^{-1}(\theta)$  is a nonsingular matrix) and if the signals  $x_d, \dot{x}_d, \ddot{x}_d$  are bounded, then the end-effector position error  $\tilde{x} = x_d - x$  and the velocity error  $\dot{\tilde{x}} = \dot{x}_d - \dot{x}$  are convergent to zero, and the equilibrium point  $[s_\vartheta^T, \tilde{x}^T]^T = 0$  is globally exponentially stable. The joint forces (which arises from (21)) are given as  $Q = \Phi^T \omega$ .

**Proof** (based on Herman (2009c)). The closed-loop system (16) and (17) together with the controller (59) can be written as:

$$\begin{aligned} & \dot{\vartheta} + C_\vartheta(\theta, \vartheta) \vartheta + G_\vartheta(\theta) + (\Phi^T)^{-1} F \Phi^{-1} \vartheta \\ & = \dot{\vartheta}_r + C_\vartheta(\theta, \vartheta) \vartheta_r + G_\vartheta(\theta) + (\Phi^T)^{-1} F \Phi^{-1} \vartheta_r + k_D s_\vartheta + J_{A\vartheta}^T k_P \tilde{x}, \end{aligned} \tag{63}$$

what leads to

$$\dot{s}_\vartheta + [C_\vartheta(\theta, \vartheta) + k_D + (\Phi^T)^{-1} F \Phi^{-1}] s_\vartheta + J_{A\vartheta}^T k_P \tilde{x} = 0. \tag{64}$$

The proposed the Lyapunov function candidate is assumed as follows:

$$\mathcal{L}(s_\vartheta, \tilde{x}) = \frac{1}{2} s_\vartheta^T s_\vartheta + \frac{1}{2} \tilde{x}^T k_P \tilde{x}. \tag{65}$$

The time derivative of  $\mathcal{L}(s_\vartheta, \tilde{x})$  along of the system trajectories (16) and (17) is given by:

$$\dot{\mathcal{L}}(s_\vartheta, \tilde{x}) = s_\vartheta^T \dot{s}_\vartheta + \dot{\tilde{x}}^T k_P \tilde{x} = s_\vartheta^T [-C_\vartheta - k_D - (\Phi^T)^{-1} F \Phi^{-1}] s_\vartheta - s_\vartheta^T J_{A\vartheta}^T k_P \tilde{x} + \dot{\tilde{x}}^T k_P \tilde{x}. \quad (66)$$

Consider the term  $-s_\vartheta^T C_\vartheta s_\vartheta$ . Calculating the time derivative of the inertia matrix  $M = \Phi^T \Phi$  (see 2.2) one obtains  $\dot{M} = \frac{d}{dt}(\Phi^T \Phi) = \dot{\Phi}^T \Phi + \Phi^T \dot{\Phi}$ . Introducing  $s_\varphi = \Phi^{-1} s_\vartheta$  and using (19) one gets:

$$\begin{aligned} -s_\vartheta^T C_\vartheta s_\vartheta &= -s_\vartheta^T [(\Phi^T)^{-1} C - \dot{\Phi}] \Phi^{-1} s_\vartheta = s_\varphi^T (\Phi^T \dot{\Phi} - C) s_\varphi \\ &= s_\varphi^T \left[ \frac{1}{2} \Phi^T \dot{\Phi} + \frac{1}{2} \Phi^T \dot{\Phi} - C + \frac{1}{2} \dot{\Phi}^T \Phi - \frac{1}{2} \dot{\Phi}^T \Phi \right] s_\varphi = s_\varphi^T \left[ \left( \frac{1}{2} \dot{M} - C \right) + \frac{1}{2} (\Phi^T \dot{\Phi} - \dot{\Phi}^T \Phi) \right] s_\varphi. \end{aligned} \quad (67)$$

Because the matrix  $(\frac{1}{2} \dot{M} - C)$  is skew-symmetric then we can use (37). Moreover, the matrix  $(\Phi^T \dot{\Phi} - \dot{\Phi}^T \Phi)$  is also skew-symmetric (see Herman (2009c)). Thus, one can write:

$$\dot{\mathcal{L}}(s_\vartheta, \tilde{x}) = -s_\vartheta^T [k_D + (\Phi^T)^{-1} F \Phi^{-1}] s_\vartheta - s_\vartheta^T J_{A\vartheta}^T k_P \tilde{x} + \dot{\tilde{x}}^T k_P \tilde{x}. \quad (68)$$

Using now (62) one obtains:

$$\begin{aligned} \dot{\mathcal{L}}(s_\vartheta, \tilde{x}) &= -s_\vartheta^T [k_D + (\Phi^T)^{-1} F \Phi^{-1}] s_\vartheta - (\dot{\tilde{x}}^T + \tilde{x}^T \Lambda^T) k_P \tilde{x} + \dot{\tilde{x}}^T k_P \tilde{x} \\ &= -s_\vartheta^T [k_D + (\Phi^T)^{-1} F \Phi^{-1}] s_\vartheta - \tilde{x}^T \Lambda^T k_P \tilde{x}. \end{aligned} \quad (69)$$

Assuming that  $k_P = \delta \Lambda$  (where  $\delta$  is a positive constant serving for the position error regulation) we have:

$$\dot{\mathcal{L}}(s_\vartheta, \tilde{x}) = -s_\vartheta^T [k_D + (\Phi^T)^{-1} F \Phi^{-1}] s_\vartheta - \tilde{x}^T \delta \Lambda^T \Lambda \tilde{x}. \quad (70)$$

As a result, one can write the above equation in the following form:

$$\dot{\mathcal{L}}(s_\vartheta, \tilde{x}) = - \begin{bmatrix} s_\vartheta \\ \tilde{x} \end{bmatrix}^T \underbrace{\begin{bmatrix} k_D + (\Phi^T)^{-1} F \Phi^{-1} & 0 \\ 0 & \delta \Lambda^T \Lambda \end{bmatrix}}_A \begin{bmatrix} s_\vartheta \\ \tilde{x} \end{bmatrix}. \quad (71)$$

Note that the symmetric matrix  $A$  is positive definite. Thus,  $\lambda_m\{A\} > 0$ . Denoting now  $x_s = [s_\vartheta^T, \tilde{x}^T]^T$  one can write

$$\dot{\mathcal{L}}(t, x_s) \leq -\lambda_m\{A\} \|x_s\|^2 \quad (72)$$

for all  $t \geq 0$  and  $x_s \in \mathbb{R}^{2N}$ .

Therefore, basing on the Lyapunov direct method Khalil (1996); Slotine & Li (1991), the conclusion that the state space origin of the system (16) and (17) together with the controller (59)

$$\lim_{t \rightarrow \infty} \begin{bmatrix} s_\vartheta(t) \\ \tilde{x}(t) \end{bmatrix} = 0 \quad (73)$$

is globally exponentially convergent can be done.

The end-effector velocity is defined by  $\dot{x} = J_A(\theta) \dot{\theta}$  Sciavicco & Siciliano (1996). Introducing the analytical Jacobian in terms of the vector  $\vartheta$  we can write the relationship  $\dot{x} = J_{A\vartheta}(\theta) \dot{\vartheta}$ . Comparing  $\dot{x}$  from both relationships and taking into account Eq.(17) we conclude that

$J_{A\vartheta}(\theta) = J_A(\theta)\Phi^{-1}$ . Moreover, in general case, instead of  $J_{A\vartheta}^{-1} = J_{A\vartheta}^{-1}(\theta)$  the right pseudo-inverse matrix  $J_{A\vartheta}^{\dagger} = J_{A\vartheta}^T(J_{A\vartheta}J_{A\vartheta}^T)^{-1}$  should be used. Based on Eq.(17) it is also assumed that  $\vartheta_r = \Phi\dot{\theta}_r$ . Kinematics singularities are the same as in  $J_A(\theta)$  because we obtain only a new Jacobian, but the structure of the manipulator is the same.

*Remark 3.* Analogous proofs can be carried out regarding the controllers in the manipulator joint space considered earlier.

### 3.3 Advantages and disadvantages of the IQV controllers

Consider some aspects of the presented controllers in terms of the IQV.

1. The controllers expressed in terms of IQV seem complicated. Note however, that the controls algorithms can be realized using quantities arising from the spatial operators which decrease their computational complexity Jain & Rodriguez (1995). Also Kane's equations are computationally effective Kane & Levinson (1983). Thus, the algorithms seem a useful tool for simulation of serial rigid manipulators.
2. The manipulator input torque  $Q$  can be calculated from the relationship  $Q = (Y^{-1})^T\pi$  and  $Q = m\epsilon$ , i.e for the controllers (30) and (42) it has have the form:

$$Q = M(\theta)\ddot{\theta}_r + C(\theta, \dot{\theta})\dot{\theta}_r + G(\theta) + k_P\tilde{\theta} + (Y^{-1})^T k_D Y^{-1} s, \quad (74)$$

$$Q = M(\theta)\ddot{\theta}_r + C(\theta, \dot{\theta})\dot{\theta}_r + G(\theta) + k_P\tilde{\theta} + m k_D m^T s. \quad (75)$$

Comparing (75) and (74) with (28) it can be seen that the difference relies on an additional term  $k_P\tilde{\theta}$  and the use of the matrix  $(Y^{-1})^T k_D Y^{-1}$  or  $m k_D m^T$  instead of the matrix  $k_D$ . The term  $k_P\tilde{\theta}$  causes that one obtains more precise trajectory tracking than using the controller (28). In spite of that in Berghuis & Nijmeijer (1993) the classical controller with the term  $k_P\tilde{\theta}$  was proposed, the controllers in terms of the IQV have one more benefit. The matrix  $m k_D m^T$  contains both kinematic and dynamical parameters which are present in the matrix  $M(\theta)$ . As a result, the matrices  $m$  and  $m^T$  give an additional gains and improve the controller performance (after some time their elements are almost constant). Similarly, the use of the controller (59), in comparison with the classical controller (50), has two advantages. First, after transformation  $Q = \Phi^T \omega$  (see (21)) the generalized force vector is as follows:

$$Q = M\ddot{\theta}_r + C(\theta, \dot{\theta})\dot{\theta}_r + G(\theta) + F\dot{\theta}_r + \Phi^T k_D \Phi s + J_A^T(\theta) k_P \tilde{x}. \quad (76)$$

Recalling (50) one can observe that the NGVC controller has two terms which are absent in the classical control algorithm. The first term contains instead of the matrix  $k_D$  the matrix  $\Phi^T k_D \Phi$ . The elements of  $\Phi^T$  and  $\Phi$  give an additional gain and, as a result, the desired position and velocity using the NGVC controller is achieved faster or with smaller coefficients of  $k_D$  than using the classical controller. The second term  $J_A^T(\theta) k_P \tilde{x}$  ensures the position error convergence in the operational space. Lack of the term causes that the proof of the error convergence can be done based on the Barbalat's Lemma Slotine & Li (1991).

3. An important advantages of the controllers in terms of the IQV arises from the fact, that the matrices  $(Y^{-1})^T k_D Y^{-1}$  or  $m k_D m^T$  reflect dynamics of the considered system. Consequently, the elements of  $k_D$  serve for tuning of gain coefficients (in contrast in (28) the matrix  $k_D$  is selected using various methods depending on experience of the user).

4. The sliding mode control algorithm described by Slotine and Li Slotine & Li (1987) enables also adaptive trajectory control. The equation (1) can be written as follows Sciavicco & Siciliano (1996):

$$M(\theta)\ddot{\theta} + C(\theta, \dot{\theta})\dot{\theta} + G(\theta) = Y(\theta, \dot{\theta}, \ddot{\theta})p = \tau \quad (77)$$

where  $p$  is an  $m$ -dimensional vector of constant parameters and  $Y$  is an  $(\mathcal{N} \times m)$  matrix which is a function of joint positions, velocities and accelerations. Decomposition of the matrix  $M$  in Eq.(1) which leads to Eq.(8) (after multiplication by the matrix  $m^{-1}$ ) causes that one obtains  $m^{-1}Y(\theta, \dot{\theta}, \ddot{\theta})p = \epsilon$ . However, for dynamics equation in terms of the nominal parameters one has  $\hat{m}^{-1}Y(\theta, \dot{\theta}, \ddot{\theta})\hat{p} = \hat{\epsilon}$ . Therefore, in terms of the NQV vector adaptation with respect to the vector of parameters  $p$  is impossible because parameters of the system are involved in matrices  $m^{-1}$  and  $\hat{m}^{-1}$ . Analogous conclusion can be made about other kinds of the IQV that is an disadvantage.

5. Robustness issue. In case where uncertainty of parameters occurs we should ask about robustness of the proposed controller. The appropriate case concerning the GVC controller is considered in Herman (2005a).

## 4. Simulation results using various controllers

### 4.1 Examples of serial manipulators

The DDA manipulator is characterized by the following set of manipulator parameters An et al. (1988) (see Table 1):

Link number $k$		1	2	3
$m_k$	kg	19.67	53.01	67.13
$J_{xx}$	kgm <sup>2</sup>	0.1825	3.8384	23.1568
$J_{xy}$	kgm <sup>2</sup>	0	0	0
$J_{xz}$	kgm <sup>2</sup>	-0.0166	0	0.3145
$J_{yy}$	kgm <sup>2</sup>	0.4560	3.6062	20.4472
$J_{yz}$	kgm <sup>2</sup>	0	-0.0709	1.2948
$J_{zz}$	kgm <sup>2</sup>	0.3900	0.6807	0.7418
$c_{xk}$	m	0.0158	0	0
$c_{yk}$	m	0	-0.0643	-0.0362
$c_{zk}$	m	0.0166	-0.1480	0.5337
$l_k$	m	0	0.462	0

Table 1. Parameters of the DDArm manipulator An et al. (1988)

The Yasukawa-like manipulator is characterized by the parameters given in Table 2. The appropriate equations of motion can be found in reference Kozlowski (1992).

### 4.2 GVC - joint space

#### 4.2.1 DDArm manipulator

In order to show performance and advantages of the controller (30) consider DDArm manipulator depicted in Figure 1(a). The results are based on Herman (2005a).

The following fifth-order polynomial was chosen for tracking: initial points  $\theta_{i1} = (-7/6)\pi$  rad,  $\theta_{i2} = (269.1/180)\pi$  rad,  $\theta_{i3} = (-5/9)\pi$  rad, and final points  $\theta_{f1} = (2/9)\pi$  rad,  $\theta_{f2} = (19.1/180)\pi$  rad,  $\theta_{f3} = (5/6)\pi$  rad, with time duration  $t_f = 1.3$  s. Starting points were different from initial points  $\Delta = +0.2, +0.2, +0.2$  rad, respectively. All simulations (were

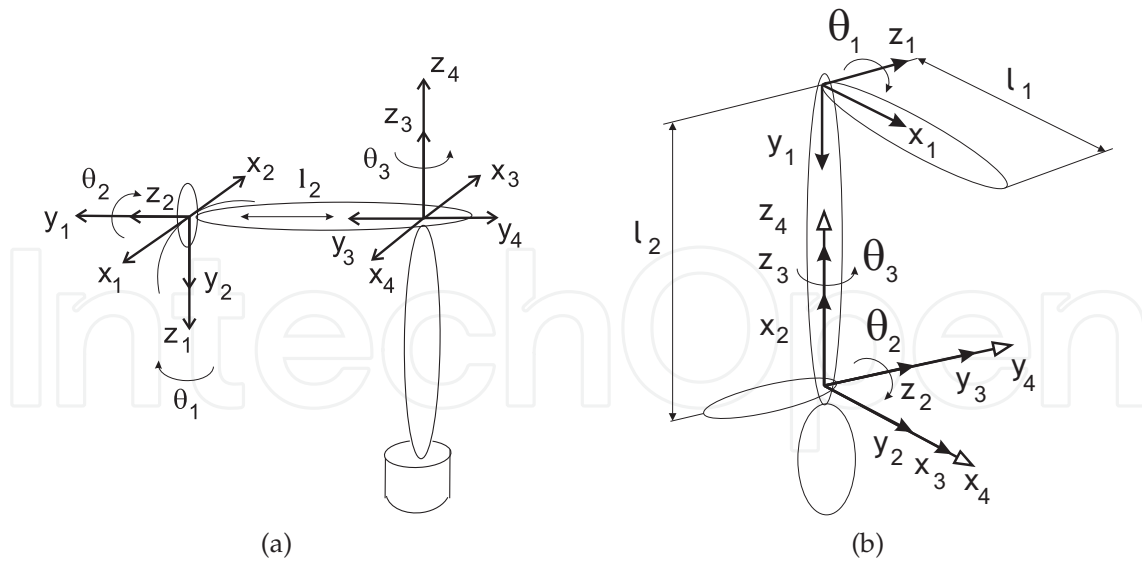

Fig. 1. Examples of spatial manipulator: (a) kinematic scheme of DDArm; (b) kinematic scheme of Yasukawa

Link number $k$		1	2	3
$m_k$	kg	10	30	65
$J_{xx}$	kgm <sup>2</sup>	0.4	0.2	0
$J_{xy}$	kgm <sup>2</sup>	0	0.01	0
$J_{xz}$	kgm <sup>2</sup>	0	-0.01	0
$J_{yy}$	kgm <sup>2</sup>	0.04	0.7	0
$J_{yz}$	kgm <sup>2</sup>	-0.01	-0.01	0
$J_{zz}$	kgm <sup>2</sup>	0.5	1.5	1.5
$c_{xk}$	m	0	0.01	0
$c_{yk}$	m	0.1	0.01	0
$c_{zk}$	m	0.01	0	0
$l_k$	m	0.4	0.65	0

Table 2. Parameters of the Yasukawa-like manipulator

realized using MATLAB with SIMULINK). The assumed diagonal control coefficients were as follows:  $k_D = \text{diag}\{10, 10, 10\}$ ,  $\Lambda = \text{diag}\{15, 15, 15\}$ ,  $k_P = \text{diag}\{150, 150, 150\}$  for the GVC controller and  $k_D = \text{diag}\{10, 10, 10\}$ ,  $\Lambda = \text{diag}\{30, 30, 30\}$  for the classical controller (CL). Diagonal values of the matrix  $\Lambda$  are two times smaller than for the classical controller in order to show some differences between both control algorithms. The set of control gains is a trade-of between acceptable position trajectory error and over-regulation.

Profiles of the desired joint position and velocity trajectories are shown in Figure 2(a). In Figures 2(b) and 2(c) the joint position errors for GVC and classical (CL) controllers are presented. The GVC controller gives similar errors for the first and the second joint. However, all errors tend to zero very quickly. For CL controller (for the third joint) position error tends slower. It can be concluded that third diagonal value of  $k_D$  and  $\Lambda$  are not sufficient to obtain comparable performance. But increasing of these gains may lead to over-regulation. Figure 2(d) – the error norm (in logarithmic scale) says that the position error is reduced faster if the GVC controller is used. From Figures 2(e) and 2(f) arises that joint torques obtained using GVC controller and CL have comparable values. Each element of the matrix  $N$  given in Figure 2(g)

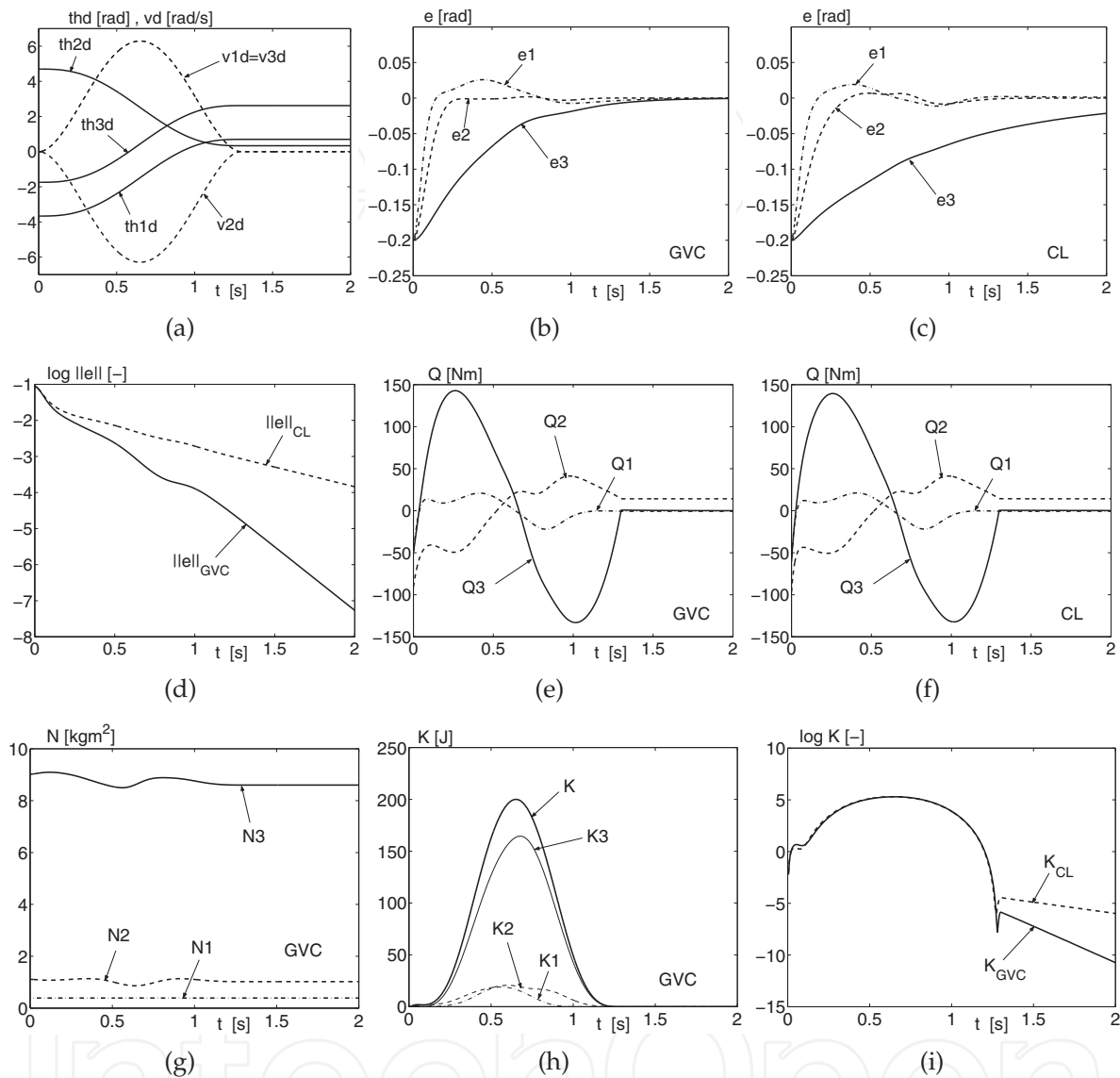

Fig. 2. Simulation results - joint space control (DDArm based on Herman (2005a)): a) profiles of desired joint position and velocity trajectory; b) joint position errors  $e$  for GVC controller; c) joint position errors  $e$  for classical (CL) controller; d) comparison between joint position error norms  $\|e\|$  (in logarithmic scale) for both controllers; e) joint torques  $Q$  obtained using GVC controller; f) joint torques  $Q$  obtained using CL controller; g) elements of matrix  $N$  obtained from GVC controller; h) kinetic energy in all joints and for the entire manipulator (GVC controller); i) comparison between kinetic energy reduction (in logarithmic scale) for both classical ( $K_{CL}$ ) and GVC ( $K_{GVC}$ ) controller

represents a rotational inertia about joint axis arising from the motion of other manipulator links. Figure 2(h) compares the kinetic energy for the whole manipulator  $K$  and for all joints. The great value of  $K3$  can be related to the dominant values of  $N3$  (the two informations can be obtained only for the GVC controller). From Figure 2(i) it is observable that the kinetic energy is reduced faster using GVC controller than using the CL controller.

#### 4.2.2 Yasukawa-like manipulator

The manipulator is depicted in Figure 1(b). The given below results are based on Herman (2009b).

The polynomial trajectories were described with initial points  $\theta_{i1} = (1/3)\pi$  rad,  $\theta_{i2} = \pi$  rad,  $\theta_{i3} = (-1/2)\pi$  rad, final points  $\theta_{f1} = (-2/3)\pi$  rad,  $\theta_{f2} = 0$  rad,  $\theta_{f3} = (1/2)\pi$  rad, and the time duration  $t_f = 1$  s. The starting points were different from the initial points  $\Delta = +0.2, +0.2, +0.2$  rad. It was assumed the following control coefficients set:  $k_D = \text{diag}\{10, 10, 10\}$ ,  $\Lambda = \text{diag}\{15, 15, 15\}$ ,  $k_P = \text{diag}\{150, 150, 150\}$  for the GVC controller (30). For the classical controller (28) we assumed the set  $k_D = \text{diag}\{10, 10, 10\}$ ,  $\Lambda = \text{diag}\{30, 30, 30\}$ . Diagonal elements values of the matrix  $\Lambda$  are two times smaller for the GVC controller than for the classical one. For the same set of coefficients performance of the classical controller are worse than for the considered case.

Profiles of the desired joint position and velocity trajectories are shown in Figure 3(a). The joint position errors for the GVC and the classical (CL) controller are shown in Figures 3(b) and 3(c), respectively. It is observable that the errors for the GVC controller tend very fast to zero and the manipulator works correctly. But for the CL controller the joint position errors tend to zero more slowly. Increasing the gain coefficients  $k_D$  or  $\Lambda$  could lead to better performance obviously under condition avoidance undesirable over-regulation. This observation confirms Figure 3(d) because the error norm (in logarithmic scale) has distinctly smaller values for the GVC controller than for the CL one. Figure 3(e) presents the joint torques obtained using the GVC controller (for the classical one they have almost the same values). In Figure 3(f) elements of the matrix  $N$  are shown (such information gives only for the GVC controller). These quantities represents some rotational inertia along each axis which arise from other links motion. They are characteristic for the tested manipulator and for the desired joint velocity set. Values  $N3$  are dominant almost all time what says that the third joint is the most laden. Figure 3(g) a kinetic energy time history for the total manipulator  $K$  and for all joints is presented. Most of the kinetic energy is related to the second joint ( $K2$ ) (and also to the same link). This fact may be associated with the dominant values  $N2$  in the time interval  $0.4 \div 0.6$  s. Figure 3(h) compares the kinetic energy reduction for the manipulator if both control algorithms are used. It can be noticed that after some time this energy is reduced much faster using the GVC controller than using the classical one.

#### 4.3 NQV - joint space

Simulations were done for the DDArm manipulator with the parameters given in Table 1 and under the same conditions. The assumed gain coefficients set was  $k_D = \text{diag}\{10, 10, 10\}$ ,  $\Lambda = \text{diag}\{15, 15, 15\}$ ,  $k_P = \text{diag}\{150, 150, 150\}$  for the NQV controller and  $k_D = \text{diag}\{10, 10, 10\}$ ,  $\Lambda = \text{diag}\{15, 15, 15\}$  for the CL one. This means also that the desired joint position and velocity trajectories are assumed as in Figure 2(a).

Simulation results obtained from the NQV controller (42) and the CL controller (28) are presented in Figure 4. The joint position errors for the NQV and the CL controller, are presented in Figure 4(a) and 4(b). One can observe that for the NQV controller all position



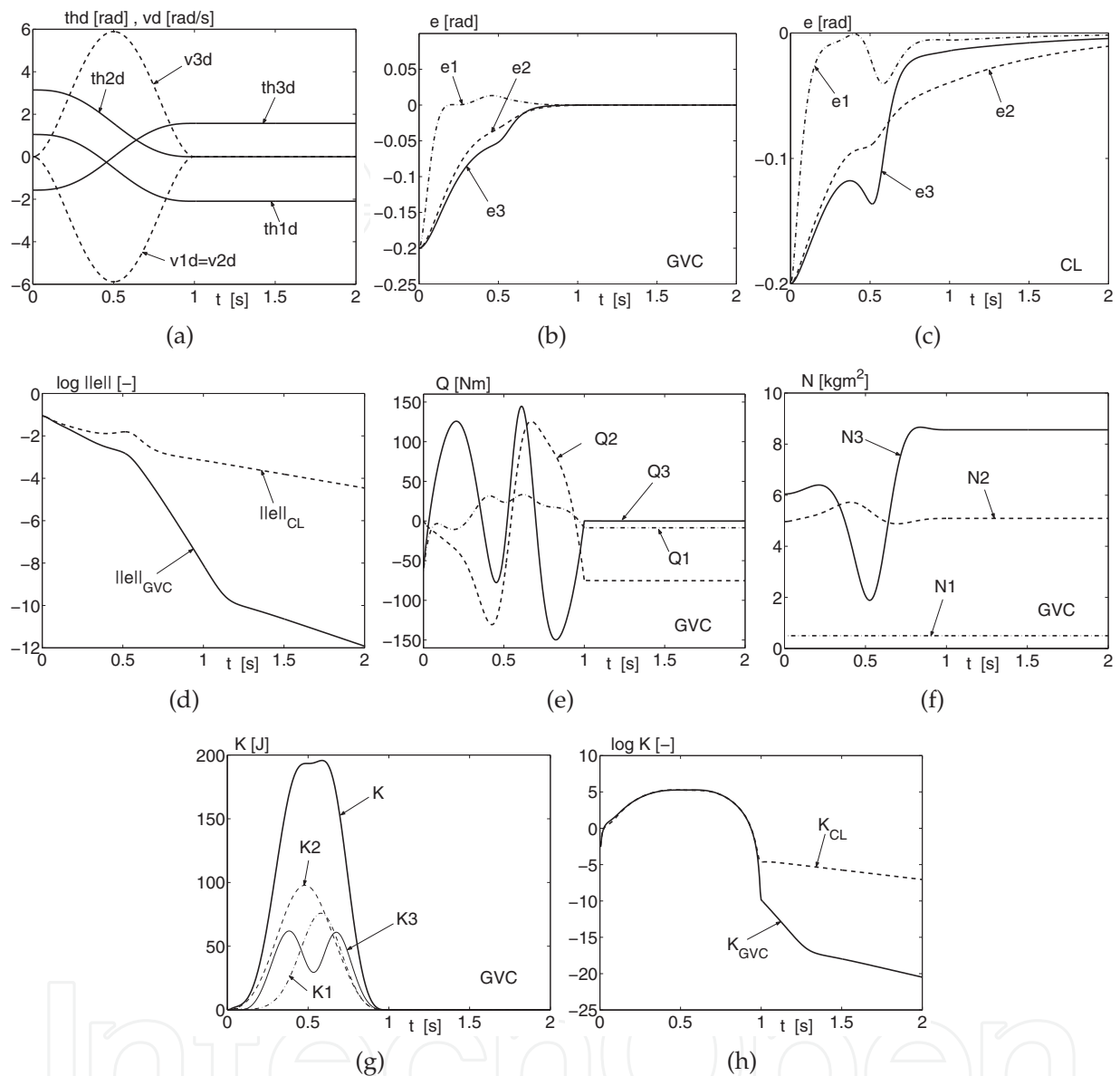

Fig. 3. Simulation results - joint space control (Yasukawa based on Herman (2009b)): a) desired joint position  $thd$  and joint velocity  $vd$  trajectory for all joints of manipulator; b) joint position errors  $e$  for GVC controller; c) joint position errors  $e$  for classical (CL) controller; d) comparison between joint position error norms  $\|e\|$  (in logarithmic scale) for both controllers; e) joint torques  $Q$  obtained using GVC controller; f) elements of matrix  $N$  obtained from GVC controller; g) kinetic energy reduced by each joints and by the total manipulator (GVC controller); h) comparison between kinetic energy (in logarithmic scale) for classical ( $K_{CL}$ ), and GVC ( $K_{GVC}$ ) controller

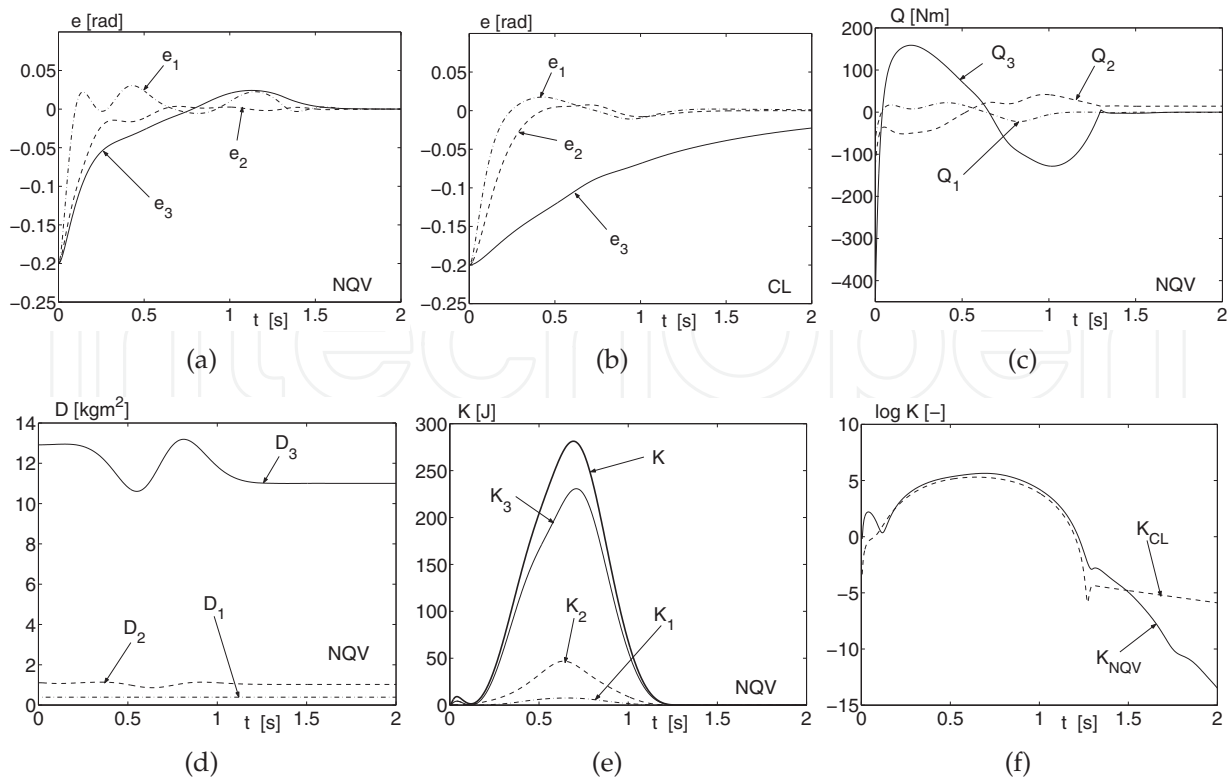

Fig. 4. Simulation results - joint space control (DDArm): a) joint position errors  $e$  for NQV controller; b) joint position errors  $e$  for CL controller; c) joint torques  $Q$  obtained using NQV controller; d) articulated inertias  $D_k$  for all joints; e) kinetic energy  $K_1, K_2, K_3$  for all manipulator joints and entire kinetic energy  $K$ ; f) comparison between kinetic energy reduction for NQV and CL controller (in logarithmic scale)

errors tend to zero after about 1.6 s. For the CL controller errors  $e_1, e_2$  tend very fast to zero but  $e_3$  tends to zero more slowly than for the NQV controller. Figure 3(c) shows the joint torques obtained from the NQV controller. The big initial value of the joint torque  $Q_3$  arises from the fact that we feed back some quantity including the kinematic and dynamical parameters of the manipulator instead of the joint velocity only. However, for the tested manipulator this value is allowed as results from reference An et al. (1988). The articulated inertia  $D_k$  for each joint (Figure 4(d)) can be obtained only using the NQV controller. Each value  $D_k$  says how much inertia rotates about the  $k$ -th joint axis. Most of the rotational inertia is transferred by the third joint axis which means that dynamical interactions are great for the third joint and the third link. Figure 4(e) gives a time history of the kinetic energy for each joint and for the manipulator. Most of the energy is related to the third link which can be explained by great values of  $D_3$ . Next Figure 4(f) compares the kinetic energy (in logarithmic scale) which is reduced by the manipulator. After about 1.6 s the kinetic energy is canceled for NQV controller much faster than for CL controller.

**4.4 GVC - operational space**

The simulation results are obtained for a 3 D.O.F. Yasukawa-like manipulator Herman (2009a). The first objective is to show performance of the GVC controller (55) in the manipulator operational space. The following parameters are different than in Table 2:

- link masses:  $m_1 = 5$  kg,  $m_3 = 60$  kg;

- link inertias:  $J_{xx2} = 0.6 \text{ kgm}^2$ ,  $J_{xz1} = 0.02 \text{ kgm}^2$ ,  $J_{yy1} = 0.05 \text{ kgm}^2$ ,  $J_{yy2} = 0.8 \text{ kgm}^2$ ,  $J_{zz2} = 2.0 \text{ kgm}^2$ ,  $J_{zz3} = 3.0 \text{ kgm}^2$ ;
- distance: axis of rotation - mass center :  $c_{x1} = 0.01 \text{ m}$ ,  $c_{x2} = 0.1 \text{ m}$ ,  $c_{y1} = 0.01 \text{ m}$ ;
- length of link:  $l_2 = 1.3 \text{ m}$ .

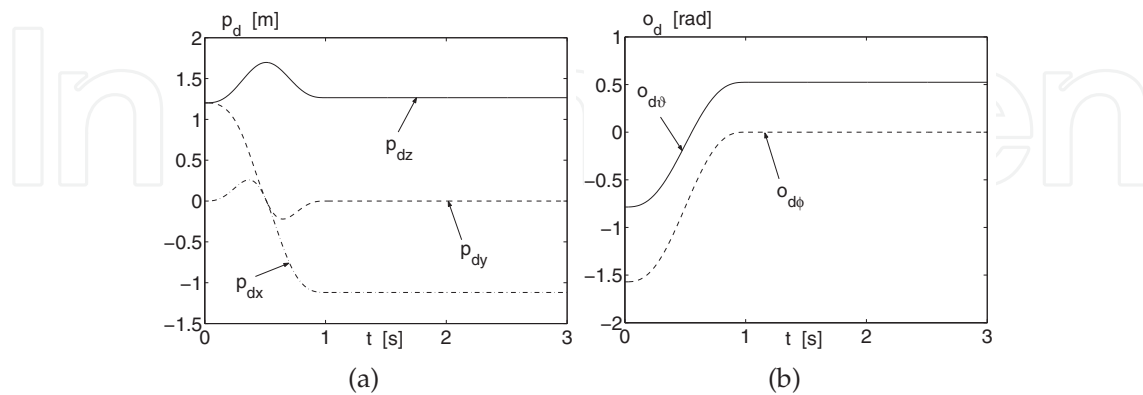

Fig. 5. Simulation results - operational space control (Yasukawa based on Herman (2009c) - the same as in Herman (2009a)): a) desired position trajectories in the operational space; b) desired orientation trajectories in the operational space (used for GVC and NGVC case)

The desired position and orientation described by the vector  $x_d = [p_{dx} \ p_{dy} \ p_{dz} \ o_{d\phi} \ o_{d\theta}]^T$  are shown in Figures 5(a) and 5(b) Herman (2009c).

The simulations results realized in MATLAB/SIMULINK (Figure 6) come from reference Herman (2009a).) The control gain matrices were assumed for all controllers as follows:  $k_D = \text{diag}\{20, 20, 20\}$ ,  $\Lambda = \text{diag}\{20, 20, 20, 20, 20, 20\}$ ,  $k_P = \text{diag}\{20, 20, 20, 20, 20\}$ ,  $\rho = 1$ . Viscous damping coefficients were the same for all joints  $F = \text{diag}\{2, 2, 2\}$ .

Figures 6(a) and 6(b) show the position and the orientation error for the GVC controller (55) in the operational space, respectively. One can observe that both errors converge to zero after about 2 s. Next, in Figures 6(c) and 6(d) the same errors for the classical controller (50) are presented. As arises from both figures in order to achieve the steady-state the controller needs more than 3 s. At the same time the orientation errors are only close to zero. In the first phase of the manipulator motion the classical controller (CL) gives smaller orientation error than the GVC controller but after about 1 s the GVC controller gives better performance. This phenomenon results from the fact that the dynamical parameters set in the controller (55) is used. From Figure 6(e) one can observe that after 1 s the kinetic energy  $K_{GVC}$  (for the GVC controller) is reduced faster than for the classical controller  $K_{CL}$  (results are presented on logarithmic scale).

In Figure 6(f) the position error norms (on logarithmic scale) measured in the manipulator task space for the GVC controller and the classical controller (CL) are compared. It can be seen that the position error norm  $\|ep\|_{GVC}$  is smaller than the error norm  $\|ep\|_{CL}$ . Comparison between the orientation error norms for both controllers are given in Figure 6(g). In the first phase of the manipulator motion the classical controller (CL) gives smaller orientation error than the GVC controller but after about 0.9 s the latter controller gives better performance. This behavior also results from the fact that the dynamical parameters set in the controller (55) is used. The joint torques for the GVC controller are shown in Figure 6(h). It is observable that at the start (before 0.2 s) the torque in the third joint  $Q_3$  has great value (it is a consequence

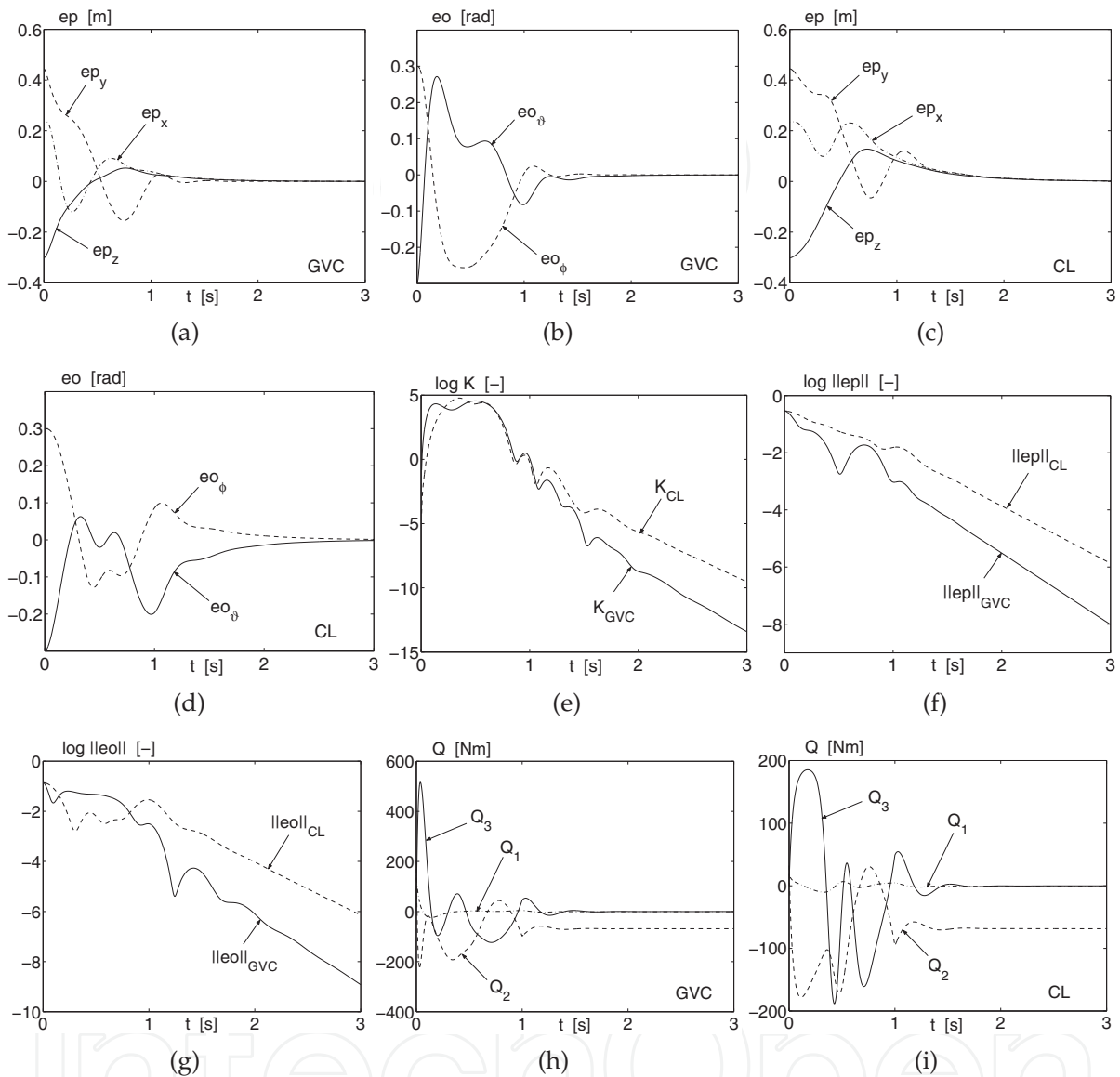

Fig. 6. Simulation results - operational space control (Yasukawa - based on Herman (2009a)): a) position errors in the operational space for GVC controller; b) orientation errors in the operational space for GVC controller; c) position errors in the operational space for classical (CL) controller; d) orientation errors in the operational space for CL controller; e) comparison between kinetic energy reduction (on logarithmic scale) for GVC and CL controller; f) comparison between position error norm on logarithmic scale for both controllers; g) comparison between orientation error norm on logarithmic scale for both controllers (GVC and CL); h) joint torques  $Q_k$  for GVC controller; i) joint torques  $Q_k$  for CL controller

of including dynamical parameters of the system in the GVC controller). As it is shown from Figure 6(i) the third joint torque for the CL controller has smaller value than using the GVC one. However, after about 0.3 s the torques for both controllers are comparable.

#### 4.5 NGVC - operational space

Consider the Yasukawa-like manipulator again. The following parameters are different than in Table 2:

- link masses:  $m_1 = 5$  kg,  $m_3 = 60$  kg;
- link inertias:  $J_{xx1} = 0.5$  kgm<sup>2</sup>,  $J_{xx2} = 0.6$  kgm<sup>2</sup>,  $J_{xz1} = 0.02$  kgm<sup>2</sup>,  $J_{yy1} = 0.05$  kgm<sup>2</sup>,  $J_{yy2} = 0.8$  kgm<sup>2</sup>,  $J_{zz3} = 3.0$  kgm<sup>2</sup>;
- distance: axis of rotation - mass center :  $c_{x1} = 0.01$  m,  $c_{x2} = 0.1$  m,  $c_{y1} = 0.01$  m,  $c_{z1} = 0.02$  m;
- length of link:  $l_2 = 1.3$  m.

The results obtained for the NGVC (59) controller are compared with the obtained from the classical controller (50) in Figures 7 and 8 Herman (2009c).

The gain matrices were chosen as (the same for both controllers, i.e. the NGVC and the CL):  $k_D = \text{diag}\{4, 4, 4\}$ ,  $\Lambda = \text{diag}\{20, 20, 20, 20, 20, 20\}$ ,  $k_P = \text{diag}\{5, 5, 5, 5, 5\}$ ,  $\delta = 0.25$  whereas the viscous damping coefficients were  $F = \text{diag}\{2, 2, 2\}$ .

In Figures 7(a) and 7(b) the position and the orientation error for the NGVC controller (59) in the operational space are shown. Both errors tend to zero after about 1.5 s. The same errors for the classical (CL) controller (50) are given in Figures 7(c) and 7(d). After 3 s (Figure 7(c)) the position steady-state is not achieved. As a result to ensure the satisfying error convergence, the CL controller needs more time than 3 s. The same conclusion can be made about the orientation error convergence (Figure 7(d)). The joint applied torques for the NGVC controller are shown in Figure 7(e). Comparing Figures 7(e) and 7(f) it can be observed that maximum values of the torques using the NGVC controller are not much larger than if the CL controller is applied.

The diagonal elements of the matrix  $\Phi$  are given in Figure 8(a) whereas the off-diagonal ones in Figure 8(b). Recall that the matrices  $\Phi^T$  and  $\Phi$  give an additional gain in the term  $\Phi^T k_D \Phi$  of the controller (59). It can be concluded that the NGVC controller uses small control coefficients  $k_{Dk}$  to ensure fast position and orientation trajectory tracking. Moreover, each element  $\Phi_{kk}^2$  represents an rotational inertia corresponding to the  $k$ -th quasi-velocity, whereas  $\Phi_{ki}$  (for  $i \neq k$ ) show dynamic coupling between the joint velocities (and also between the appropriate links). Such information is available only from the NGVC controller.

From Figure 8(c) it can be seen that the kinetic energy  $K$  which must be reduced by the manipulator concerns mainly the third quasi-velocity  $K_3$  (and also by the 3-th link). Figure 8(d) compares the kinetic energy reduction (on logarithmic scale) for both controllers. After about 1 s the kinetic energy  $K_{NGVC}$  for the NGVC controller decreases faster than for the classical controller  $K_{CL}$ . Consequently, the NGVC control algorithm gives faster error convergence than the CL control algorithm.

#### 4.6 Discussion

From the presented simulation results arises the fact that the proposed nonlinear controllers in terms of the IQV ensures faster, than the classical controller, the position and orientation error convergence. Moreover, the kinetic energy reduction is also faster if the IQV controller is used. An disadvantage of the IQV controllers is that sometimes, at the beginning of motion, great

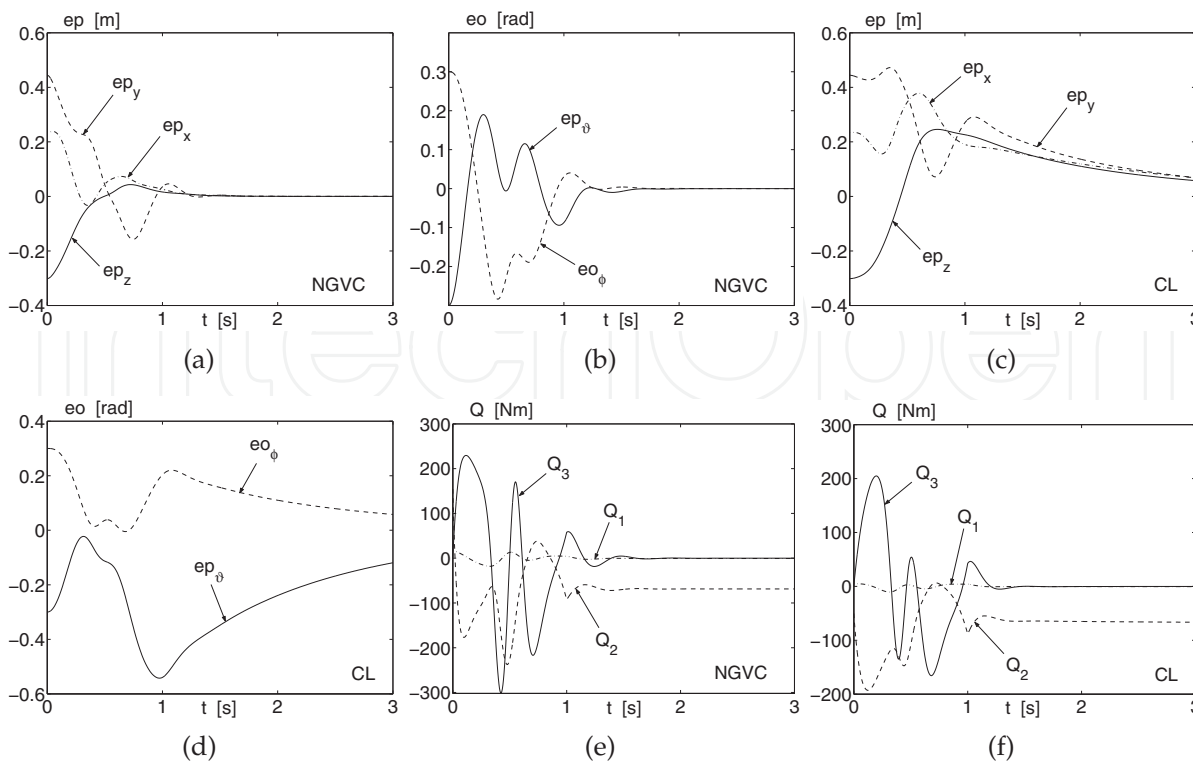

Fig. 7. Simulation results - operational space control (Yasukawa - based on Herman (2009c)): a) position errors in the in the operational space for NGVC controller; b) orientation errors in the operational space for NGVC controller; c) position errors in the operational space for classical (CL) controller; d) orientation errors in the operational space for classical (CL) controller; e) joint applied torques  $Q$  for NGVC controller; f) joint applied torques  $Q$  for CL controller

initial torque can occur. The great values come from including the manipulator parameters set into the control algorithm. Note, however that the same reason causes the benefit concerning the fast error convergence and fast kinetic energy reduction. Thus, it should be verified if for the considered manipulator the real torques are acceptable. It can be done via simulation because the expected torques are determined from the time history of  $Q$ . To obtain comparable results as for the IQV controller we have to assume for the CL controller the matrix  $k_D$  with bigger gain coefficients. However, at the same time elements of the matrix  $\Lambda$  should be enough great to ensure fast error convergence. From all presented cases arise that if the IQV controller is used then the gain matrix  $k_D$  has rather small values. One can say that they serve for precise tuning because the resultant gain matrix is related to the system dynamics.

### 5. Conclusion

In this paper, a review of a theoretical framework of non-adaptive sliding mode controllers in terms of the inertial quasi-velocities (IQV) for rigid serial manipulators was provided. The dynamics of the system using several kind of the IQV, namely: the GVC, the NQV, and the NGVC was presented. The IQV equations of motion offer some advantages which are inaccessible if the classical second-order differential equations are used. The IQV sliding mode control algorithms, based on the decomposition of the manipulator inertia matrix, can be realized both in the manipulator joint space and in its the operational space. It was shown

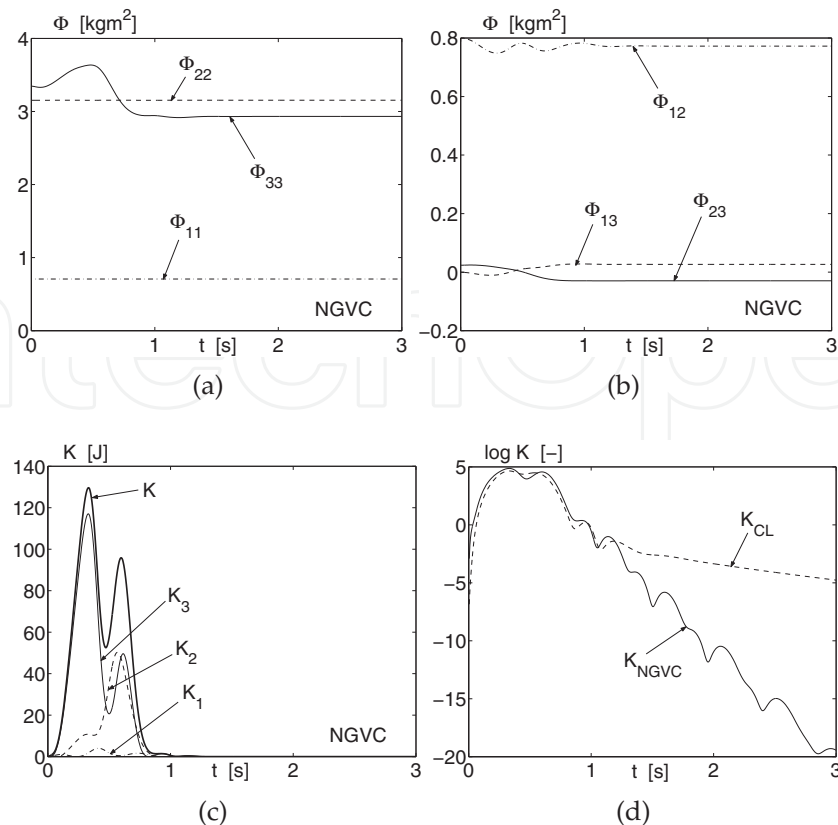

Fig. 8. Simulation results - operational space control (Yasukawa - based on Herman (2009c)): a) diagonal elements of the matrix  $\Phi$ ; b) other elements of the matrix  $\Phi$ ; c) kinetic energy time history corresponding to each quasi-velocity  $\vartheta_k$ ; d) comparison between kinetic energy reduction (on logarithmic scale) for the NGVC controller and the CL controller

that the considered controllers are made the equilibrium point globally asymptotically or exponentially stable in the sense of Lyapunov. Some advantages and disadvantages of the IQV controllers were also given in the work. Moreover, the proposed control schemes are also feasible if the damping forces are taken into account. Simulations results for two different 3 D.O.F. spatial manipulators have shown that the IQV controllers can give faster position and orientation error convergence and/or using smaller velocity gain coefficients than the related classical control algorithms. Faster kinetic energy reduction is also possible if the classical controller is replaced by the IQV one. It is worth noting that the discussed controllers can serve for dynamical coupling detection between the manipulator links via simulation which allows one to avoid some expensive experimental tests.

Future works should concern investigation of the IQV controllers with models of friction, especially with Coulomb friction and dynamic friction models. In order to show real performance and properties of the controllers, experimental validation is expected.

## 6. References

- An, Ch.H.; Atkeson, Ch.G. & Hollerbach, J.M. (1988). *Model-Based Control of a Robot Manipulator*, The MIT Press.
- Berghuis, H. & Nijmeijer, H. (1993). A Passivity Approach to Controller - Observer Design for Robots. *IEEE Transactions on Robotics and Automation*, Vol.9, No. 6: 740-754.

- Herman, P. (2005a). Sliding mode control of manipulators using first-order equations of motion with diagonal mass matrix. *Journal of the Franklin Institute*, Vol.342, No. 4: 353-363.
- Herman, P. (2005b). Normalised-generalised-velocity-component-based controller for a rigid serial manipulator. *IEE Proc. - Control Theory & Applications*, Vol.152, No.5: 581-586.
- Herman, P. (2006). On using generalized velocity components for manipulator dynamics and control. *Mechanics Research Communications*, Vol.33, No. 3: 281-291.
- Herman, P. (2009a). A nonlinear controller for rigid manipulators, PapersOnline: *Methods and Models in Automation and Robotics*, Vol. 14, Part 1, 10.3182/20090819-3-US-00105.
- Herman, P. (2009b). Strict Lyapunov function for sliding mode control of manipulators using quasi-velocities. *Mechanics Research Communications*, Vol.36, No. 2: 169-174.
- Herman, P. (2009c). A quasi-velocity-based nonlinear controller for rigid manipulators. *Mechanics Research Communications*, Vol.36, No. 7: 859-866.
- Hurtado, J.E. (2004). Hamel Coefficients for the Rotational Motion of a Rigid Body. *The Journal of the Astronautical Sciences*, Vol.52, Nos.1 and 2: 129-147.
- Jain, A. & Rodriguez, G. (1995). Diagonalized Lagrangian Robot Dynamics. *IEEE Transactions on Robotics and Automation*, Vol.11, No.4: 571-584.
- Junkins, J.L. & Schaub H. (1997). An Instantaneous Eigenstructure Quasivelocety Formulation for Nonlinear Multibody Dynamics. *The Journal of the Astronautical Sciences*, Vol.45, No.3: 279-295.
- Kane, T.R. & Levinson D.A. (1983). The Use of Kane's Dynamical Equations in Robotics. *The International Journal of Robotics Research*, Vol.2, No.3: 3-21.
- Kelly R. & Moreno J. (2005). Manipulator motion control in operational space using joint velocity inner loops. *Automatica*, Vol.41, No. 8: 1423-1432.
- Khalil, H. (1996). *Nonlinear Systems*, Prentice Hall, New Jersey.
- Kozłowski, K. (1992). *Mathematical Dynamic Robot Models and Identification of Their Parameters*, Poznan University of Technology Press, Poznan, (in Polish).
- Kwatny, H.G. & Blankenship, G.L. (2000). *Nonlinear Control and Analytical Mechanics*, Birkhäuser, Boston.
- Loduha T.A. & Ravani B. (1995). On First-Order Decoupling of Equations of Motion for Constrained Dynamical Systems. *Journal of Applied Mechanics - Transactions of the ASME*, Vol.62, March: 216-222.
- (1996). *MATLAB, Using Matlab*, The MathWorks, Inc.
- Mochiyama, H.; Shimemura, E. & Kobayashi H. (1999). Shape Control of Manipulator with Hyper Degrees of Freedom. *The International Journal of Robotics Research*, Vol.18, No.6: 584-600.
- Moreno, J. & Kelly, R. (2003). Velocity control of robot manipulators: analysis and experiments. *International Journal of Control*, Vol.76, No.14: 1420-1427.
- Moreno, J.; Kelly, R. & Campa, R. (2003). Manipulator velocity control using friction compensation. *IEE Proc. - Control Theory and Applications*, Vol.150, no.2: 119-126.
- Moreno-Valenzuela J. & Kelly R. (2006). A Hierarchical Approach Manipulator Velocity Field Control Considering Dynamic Friction Compensation. *Journal of Dynamic Systems, Measurement, and Control - Transactions of the ASME*, Vol.128, September: 670-674.
- Santibanez, V. & Kelly R. (1997). Strict Lyapunov Functions for Control of Robot Manipulators. *Automatica*, Vol.33, No.4: 675-682.
- Sciavicco L. & Siciliano B. (1996). *Modeling and Control of Robot Manipulators*, The McGraw-Hill Companies, Inc., New York.



- Slotine J.-J., & Li W. (1987). On the Adaptive Control of Robot Manipulators. *The International Journal of Robotics Research*, Vol.6, No.3: 49-59.
- Slotine J.-J. & Li W. (1991). *Applied Nonlinear Control*, Prentice Hall, New Jersey.
- Sovinsky, M.C.; Hurtado, J.E.; Griffith D.T. & Turner, J.D. (2005). The Hamel Representation: Diagonalized Poincaré Form, *Proceedings of IDETC'05 2005 ASME International Design Engineering Technical conference and Computers and Information in Engineering Conference*, DETC2005-85650, Long Beach, California, USA, September 24-28, 2005.
- Spong, M.W. (1992). On the Robust Control of Robot Manipulators. *IEEE Transactions on Automatic Control*, Vol.37, No.11: 1782-1786.

IntechOpen



## **Sliding Mode Control**

Edited by Prof. Andrzej Bartoszewicz

ISBN 978-953-307-162-6

Hard cover, 544 pages

**Publisher** InTech

**Published online** 11, April, 2011

**Published in print edition** April, 2011

The main objective of this monograph is to present a broad range of well worked out, recent application studies as well as theoretical contributions in the field of sliding mode control system analysis and design. The contributions presented here include new theoretical developments as well as successful applications of variable structure controllers primarily in the field of power electronics, electric drives and motion steering systems. They enrich the current state of the art, and motivate and encourage new ideas and solutions in the sliding mode control area.

### **How to reference**

In order to correctly reference this scholarly work, feel free to copy and paste the following:

Przemyslaw Herman and Krzysztof Kozlowski (2011). Non-Adaptive Sliding Mode Controllers in Terms of Inertial Quasi-Velocities, Sliding Mode Control, Prof. Andrzej Bartoszewicz (Ed.), ISBN: 978-953-307-162-6, InTech, Available from: <http://www.intechopen.com/books/sliding-mode-control/non-adaptive-sliding-mode-controllers-in-terms-of-inertial-quasi-velocities>

**INTECH**  
open science | open minds

### **InTech Europe**

University Campus STeP Ri  
Slavka Krautzeka 83/A  
51000 Rijeka, Croatia  
Phone: +385 (51) 770 447  
Fax: +385 (51) 686 166  
[www.intechopen.com](http://www.intechopen.com)

### **InTech China**

Unit 405, Office Block, Hotel Equatorial Shanghai  
No.65, Yan An Road (West), Shanghai, 200040, China  
中国上海市延安西路65号上海国际贵都大饭店办公楼405单元  
Phone: +86-21-62489820  
Fax: +86-21-62489821

© 2011 The Author(s). Licensee IntechOpen. This chapter is distributed under the terms of the [Creative Commons Attribution-NonCommercial-ShareAlike-3.0 License](https://creativecommons.org/licenses/by-nc-sa/3.0/), which permits use, distribution and reproduction for non-commercial purposes, provided the original is properly cited and derivative works building on this content are distributed under the same license.

IntechOpen

IntechOpen