

We are IntechOpen, the world's leading publisher of Open Access books Built by scientists, for scientists

5,200

Open access books available

129,000

International authors and editors

150M

Downloads

Our authors are among the

154

Countries delivered to

TOP 1%

most cited scientists

12.2%

Contributors from top 500 universities



WEB OF SCIENCE™

Selection of our books indexed in the Book Citation Index
in Web of Science™ Core Collection (BKCI)

Interested in publishing with us?
Contact book.department@intechopen.com

Numbers displayed above are based on latest data collected.
For more information visit www.intechopen.com



The Synthetic Control of SMC and PI for Arc Welding/cutting Power Supply

Guo-Rong Zhu¹ and Yong Kang²

¹The Hong Kong Polytechnic University

²Huazhong University of Science and Technology
China

1. Introduction

Nowadays, the manufacture of arc welding/cutting power source is mainly based on analog control in converters (Cho et al., 1996), in which component parameter flutters and performance varies with the changing of the environment and time. Owing to the fact that digital control technology is flexible, exact and reliable, it is the up-to-date method used in soft-switch arc welding/cutting power supply. The main circuit of high power arc welding/cutting power supply often uses Phase-Shift Full-Bridge (PS-FB) topology. As to PS-FB DC/DC converter circuit, there are generally three control methods: PID control, sliding mode control and fuzzy control. PID control is the most commonly used with simple algorithm, great steady-state performance and no steady-state error in the output, however, its dynamic performance is poor. Sliding mode control has excellent dynamic performance while it cannot guarantee no steady-state error in the output due to inertia that actual systems always have (He et al., 2004). Fuzzy control has good robustness, but its algorithm is complicated and its accuracy is low (Arulselvi et al., 2004). According to the basic characteristics of arc welding and cutting, from no-load to load, current is detected and it is expected that building current quickly with appropriate current overshoot to pilot arc easily and no steady-state error, PID control is more suitable for this case; from load to no-load, voltage is detected and it is expected that building voltage quickly with small voltage overshoot and it is not necessary high accuracy of voltage control, sliding mode control is more suitable for this case.

In this paper, the basic electrical characteristics and the needs of arc welding/cutting power supply, such as load current, short current and no-load voltage are analyzed. Considering to the grid voltage fluctuation, economical and personal safety, the arc welding/cutting power supply with synthetic control of Sliding Mode Control (SMC) and PI is researched and designed. Through demonstrating the external characteristic demands of welding/cutting power supply and analyzing the control algorithm, PI control is used on the current loop and SMC is introduced on the voltage loop. This method has not only effectively solved the voltage overshoot, but also realized a faster voltage resume to pilot arc again quickly. The control algorithm of phase shift full bridge indirect SMC based on the average state space model is deduced theoretically, and a direct phase shift PWM wave generation method is applied, which makes the control more practical and simpler. Some experiments on a 20

kW arc welding/cutting power source are conducted by digital control between the synthetic control of SMC and PI and the single PI control on TMS320LF2407. The results prove the effectiveness and robustness of the SMC and PI synthetic control.

2. The circuit topology and external characteristic

2.1 The circuit topology

In this soft-switch arc welding/cutting power supply, the Phase-Shift Full-Bridge ZVS (FB-ZVS-PWM) converter (Ruan et al., 2001) is employed. Although the volt-ampere characters and the ranges of voltage and current of arc welding machines and cutting machines are different, they both share the fundamental output characters of quickly slope voltage and invariable current; therefore, a machine with the multi-functions of arc welding and cutting can be developed. The secondary side of high frequency transformer can be shifted to output full-wave converter in arc welding, through which high current and low voltage can be obtained. It can be switched to output full-bridge converter in cutting, through which high voltage and low current can be obtained. Changing output converter mode means changing the voltage ration of the high frequency transformer, which can meet the two work situations only by shifting a switch (Zhu et al., 2007).

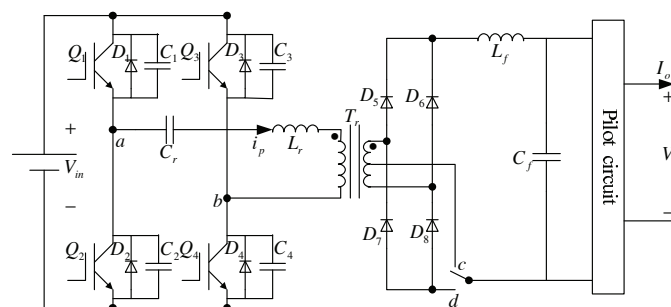

Fig. 1. The topology of the soft-switch arc welding/cutting power supply

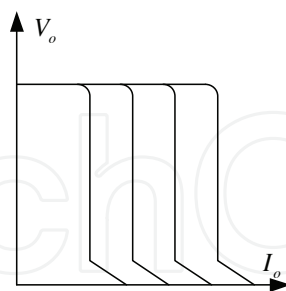

Fig. 2. Arc welding/cutting external characteristics curve

The topology of the soft-switch arc welding/cutting power supply is shown in Fig.1. In Fig.1, Q_1, D_1, C_1 and Q_2, D_2, C_2 are leading leg switches, Q_3, D_3, C_3 and Q_4, D_4, C_4 are lagging leg switches, and ZVS is realized by paralleling capacitors to the switches and resonance inductor. The topology shown in Fig.1 is mainly based on the following considerations: (1)The circuit is simple, which can realize the 4 switches ZVS without any more switches, which are advantage from the phase shift control method, and which changes the output voltage through changing phase shift angle.

(2)PWM (pulse width modulation) control strategy is adopted. Switching frequency is constant, so the designs of high frequency transformer and filtering links of input and output are easy.

In Fig.1, shifting the switch point to the c point means that the secondary side of high frequency transformer constructs output full-wave converter when working in arc welding. Shifting the switch point to the d point means that the secondary side of high frequency transformer constructs output full-bridge converter when working in cutting. A separate pilot arc circuit is in series to the main circuit in cutting, which can be started by the cutting gun. The characteristic of phase-shift full-bridge soft switching power source is that the circuit structure is simple, compared with hard switching power source, only one resonant inductor is added which can make the four switches in the circuit work to realize ZVS.

2.2 The external characteristics of arc welding/cutting power supply

Arc welding/cutting power source has two working modes which alternate when arc welding/cutting power source is under work. One is constant-voltage control in the no-loaded mode while the other is working as constant-current source when loaded. Arc welding/cutting power source with good performance requires that the alteration between the two modes can be as fast as possible. As shown in Fig.2, if the external characteristic curve is steeper, the performance is better (Zheng et al., 2004). There, V_o is the output voltage and I_o is the output current.

3. Sliding mode control for arc welding/cutting power supply

Block diagram of converter system is shown in Fig.3. This paper selects two digital loop alternate control strategy (G.R.Zhu et al., 2007). Fig.3 shows that the digital system includes two control loops, one is current loop, and the other is voltage loop. Current loop samples from output current, and the sampling signal is processed by TMS320LF2407 DSP chip to get inverse feedback signal for the current digital regulator. The voltage loop samples from the output voltage, and the sampling signal is also processed by the DSP chip to get the inverse voltage feedback signal for the voltage digital regulator. The output voltage and current of the proposed converter are sensed by sensors and converted by A/D of DSP as feedback after being filtered by digital low pass filter. According to the basic characteristics of arc welding and cutting, from no-load to load, current is detected and it is expected that building current quickly with appropriate current overshoot to pilot arc easily and no steady-state error on work process, PID control is more suitable for this case; from load to no-load, voltage is detected and it is expected that building voltage quickly with small voltage overshoot, PID control has contradictory between the small overshoot and the fast response time, namely, overshoot will be increased due to fast response, which should be avoided in the voltage loop. Thus, a new control method is needed to solve voltage loop problem. Because of its good dynamic characteristic and small overshoot, sliding mode control can be applied in this field.

3.1 The fundamental principle of sliding mode Control

Sliding mode control is a control method in changing structure control system. Compared with normal control, it has a switching characteristic to change the structure of the system with time. Such characteristic can force system to make a fluctuation with small amplitude and

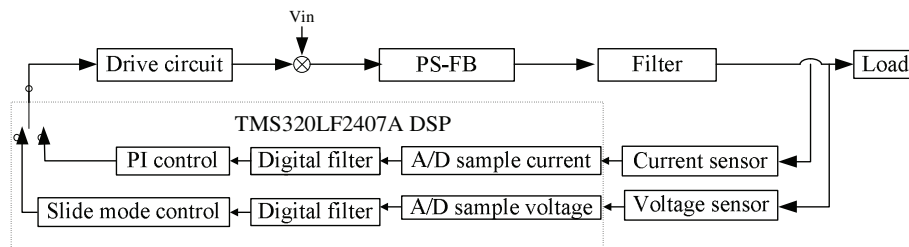

Fig. 3. Block diagram of converter system

high frequency along state track under determinate trait which can also be called as sliding mode movement. System under sliding mode has good robustness because the sliding mode can be designed and it has nothing to do with parameters and disturbances of the system. Theoretically speaking, sliding mode control has better robustness compared with normal continuous system, but it will result in fluctuation of the system due to the dis-continuousness of the switching characteristic. This is one of the main drawbacks of the sliding mode control and can't be avoiding as the switching frequency cannot be infinite. However, such effect can be ignored because high accuracy of voltage control is not required in arc welding/cutting power source.

3.2 The sliding mode digital control of phase shift full bridge

As the structure of phase-shift full-bridge main circuit is different when the switches are at different on-off state, it is suitable to use sliding mode control. Traditional sliding mode control is realized by hysteresis control, owing to the switching frequency is fixed in phase-shift full-bridge circuit, duty cycle is used for indirectly control instead of frequency directly using sliding mode control to control the switch. (Shiau et al., 1997)

When the switches Q_1 and Q_4 (or Q_2 and Q_3) in Fig.1 are switching on at the same time, its equivalent circuit is shown in Fig.4(a).

When the switches Q_1 and Q_4 (or Q_2 and Q_3) in Fig.1 are not switching on at the same time, its equivalent circuit is shown in Fig.4(b).

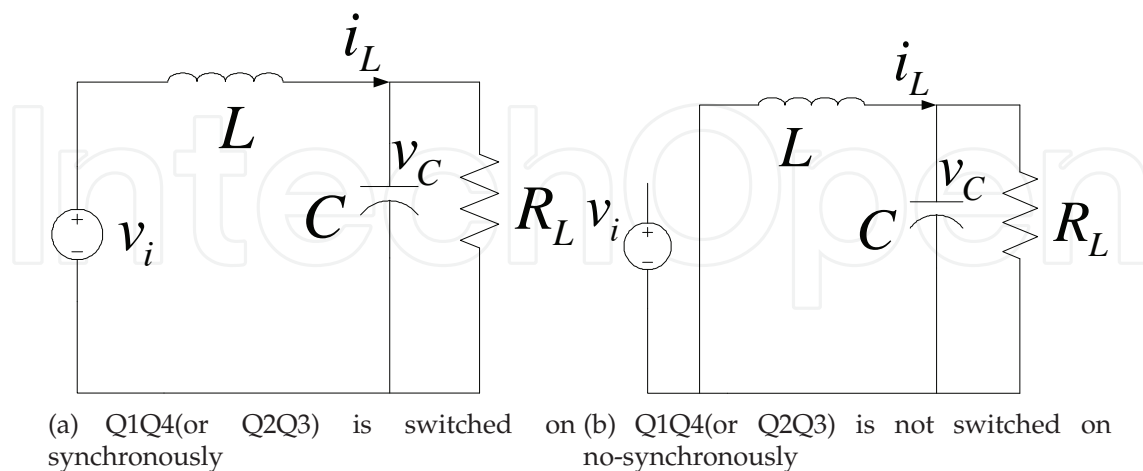

Fig. 4. The equivalent circuit of PS-FB-ZVS

Set inductance current and capacitance voltage as variables, by using state-space average method, the equation of phase-shift full-bridge is:

$$\begin{cases} \dot{i}_L = -\frac{1}{L}v_c + \frac{1}{L}dv_i \\ \dot{v}_c = \frac{1}{C}i_L - \frac{1}{R_L C}v_c \end{cases} \quad (1)$$

where d is duty cycle.

Choose voltage error as the state variable for the system:

$$e = v_c - v_{ref} \quad (2)$$

Then,

$$de/dt = \dot{v}_c = \frac{1}{C}i_L - \frac{1}{R_L C}v_c \quad (3)$$

Besides choose the switch function:

$$S = de/dt + ke \quad (4)$$

Take the Equation 2, Equation 3 into Equation 4, then can get:

$$S = \frac{1}{C}i_L - \frac{1}{R_L C}v_c + k(v_c - v_{ref}) \quad (5)$$

$$\dot{S} = \frac{1}{LC}dv_i + (\frac{k}{C} - \frac{1}{R_L C^2})i_L - (\frac{k}{R_L C} - \frac{1}{R_L^2 C^2} + \frac{1}{LC})v_c \quad (6)$$

Let

$$\dot{S} = 0 \quad (7)$$

then

$$d_{eq} = [(\frac{kL}{R_L} - \frac{L}{R_L^2 C} + 1)v_c - (kL - \frac{L}{R_L C})i_L] / v_i \quad (8)$$

Besides let $d = d_{eq} + d_n$ čnto meet the requirements of sliding mode control $S \times \dot{S} < 0$, then $S \times \frac{1}{LC}d_n v_i < 0$, so:

$$d_n = a - b \operatorname{sgn}(S) \quad (9)$$

where, sgn is the symbol function, a and b are selected by the implement systems. $R_L \rightarrow \infty$ when no-loaded čntwe can get:

$$d_{eq} = (v_c - kLi_L) / v_i \quad (10)$$

The block diagram of phase-shift full bridge SMC is shown in Fig.5.

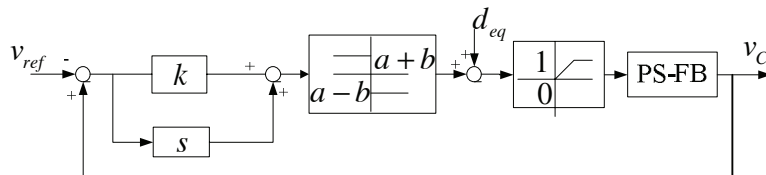

Fig. 5. Phase-shift full-bridge SMC chart

3.3 Digital control system structure and phase shift realization principle

Digital control system of the soft-switch arc welding/cutting power supply is shown in Fig.3. In this study, Digital Signal Processor (DSP) TMS320LF2407 provided by Texas Instruments is selected for implementation because of its function and simple architecture (TI et al., 2000). The features of this DSP are: A/D converter (10-bit), two event managers to generate PWM signals, 4 timer/counter (16-bit). The core of the hardware system is DSP, around which the circuits, which includes sampling circuit, protection circuit, DSP external circuit and drive circuit, are designed in detail. The output voltage and current of the proposed converter are sensed by sensors and converted by A/D of DSP as feedback after being filtered by digital low pass filter.

As to full bridge phase shift circuit, the most important problem is how to create phase shift pulse in the digital control system. A direct phase shift pulse method based on the DSP symmetric PWM waveform generation with full compare units is applied. The method is shown in Fig.6.

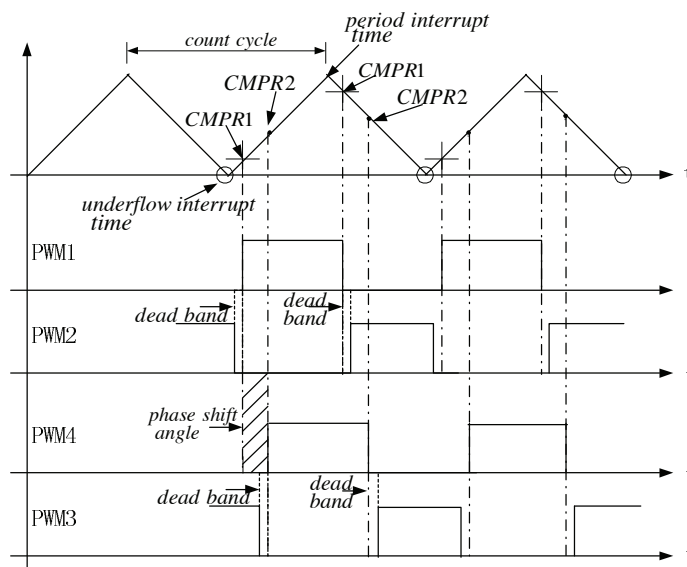

Fig. 6. Direct phase shift pulse methods with DSP full compare units

In Fig.6, the direct phase shift pulse method with DSP full compare units is that the two full compare units of the DSP Event Manager A (EVA) directly produce four PWM pulses. The fundamental theory of phase shift angle is that there is a periodic delay time from the leading leg drive to lagging leg drive. The two up/down switches drive pulses of the leading leg are produced by the full compare unit 1, and the two up/down switches drive pulses of the lagging leg are produced by the full compare unit 2. The up and down switching of each leg drive pulses are reverse and between them exists the dead band. If the given data of the leading leg register CMPR1 is fixed, the given data of phase shift angle register CMPR2 comes from full compare event, which can produce the lagging leg drive pulse. Therefore, this method can realize $0^\circ - 180^\circ$ phase shift. The data of CMPR1 and CMPR2, which is the compare register of the two full compare units, varies in the underflow interrupt and period interrupt with the demand of the system regulator. The falling edge compare data is given in the underflow interrupt, rising edge compare data is given in the period interrupt, and the counter data is the pulse period.

In the program, the control register is set by symmetric PWM waveform generation with full compare units, Timer 1 must be put in the continuous up/down counting mode, and dead band can be set directly through Dead-Band Timer Control Register (DBTCR). In a word, the direct phase shift pulse method does not need more hardware to synthesize pulse (Kim et al., 2001), so it is very simple, flexible, convenient and reliable.

When fault comes out, such as over voltage or over current for the output, over current for the direct current bus, over voltage or under voltage for the input, overheating for the machine and etc, the peripheral hardware generates signal to lock-out the pulse amplifying circuit and the rectifier circuit, meanwhile generates PDPINTA signal to send to DSP within which PDPINTA interrupt is generated to lock-out pulse.

The phase shift PWM waves generated by the EVA module of the DSP and regulator are driven and amplified to control the power semiconductors IGBT of the high-frequency link converter. Moreover, the system can control the arc welding/cutting voltage and current by zero switching (Ben et al., 2005).

4. Experiment result

In this paper, a lab prototype of the 20W arc welding/cutting machine was built, and the specifications and designed components values are summarized in Table 1

Vin(input voltage)	DC 540V±20V
Po (output power)	20kVA
Unload voltage (arc welding)	70V
Output current (arc welding)	40A-500A (adjustable)
Unload voltage (cutting)	200V
Output current (cutting)	40A-100A (adjustable)
Switching frequency	20kHz
Controller	TMS320LF2407
Resonance inductor Lr	16uH
Leading leg parallel capacitor	8nF
Lagging leg parallel capacitor	4.7nF

Table 1. Specifications and compents used in experiment

Different switch functions are selected on different operation condition. $k = 1000$ when cutting, switch function $S = de/dt + 1000e$. It can be slided to sliding mode surface until stable output when the output voltage is 10-240V. So, $\frac{10}{330} \leq d_{eq} \leq \frac{240}{330}$, then $-\frac{1}{33} \leq d_n \leq \frac{9}{33}$, so $d_n = \frac{4}{33} - \frac{5}{33} \text{sgn}(S)$.

Similarly, $k = 600$ when arc welding, switch function $S = de/dt + 600e$. It can be slided to sliding mode surface until stable output when the output voltage is 10-80V, then, $d_n = \frac{5}{16} - \frac{6}{16} \text{sgn}(S)$.

Fig.7(a) shows the output voltage with SMC to control the no-load voltage from load to no-load mode when arc welding, while Fig.7(b) shows the wave with PI control is used from load to no-load mode when arc welding. In Fig.7(a) and Fig.7(b), we can see that sliding mode control can meet the requirement of fast voltage response and small voltage overshoot than PI control. Although PI control can also decrease the voltage overshoot by adjusting proportion factor, response time is affected, especially the regulation time increases from load to no-loaded mode.

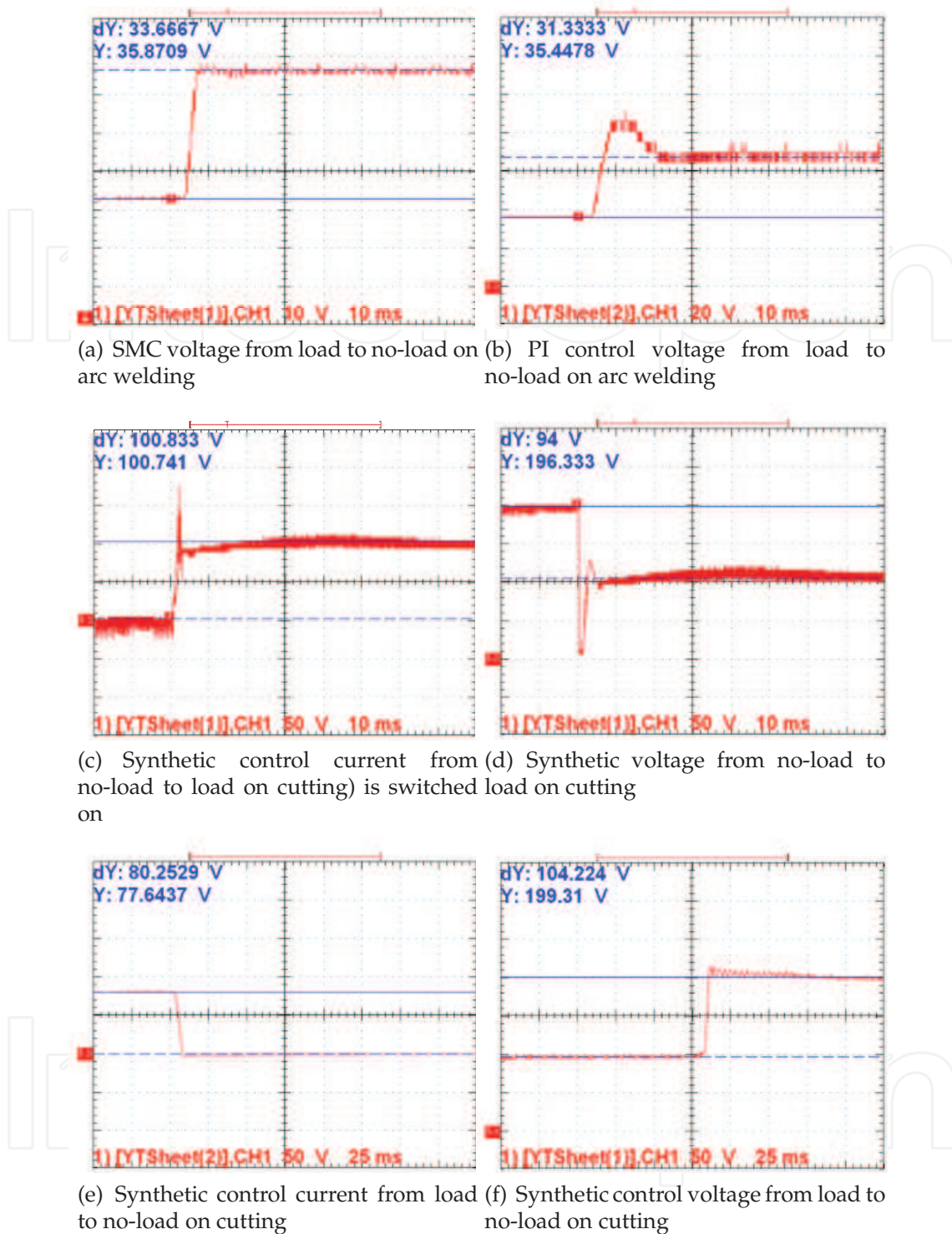

Fig. 7. The experiment waves of output voltage and current when arc welding or cutting

Based on the synthetic control of SMC and PI when the machine is used to cut 25mm thick mild steel work piece, in which input voltage is 523V and output current is 100A, and no-loaded voltage is 200V, the waveforms of the output voltage and output current are shown in Fig.10. The output voltage and current waveforms in cutting process from no-load to load shown in Fig.7(c)-Fig.7(f). In Fig.7(c)(d), at first voltage loop is running when the current is

zero, then current increases after pilot arc, when current is bigger than some giving value, current loop is running. There are some current overshoot with PI control in current loop, which is advantage to pilot success, and no steady-state error of current, which is advantage to steady arc welding/cutting process. In Fig.7(e)(f), the switch from load to no-load is quick and no any overshoot based on SMC control. From Fig.7(a)(f), since the scope of adjustable voltage is different, the k in sliding mode function is different, the speed of building voltage also is different, thus k is the adjustable parameter according to different system in SMC.

5. Conclusion

Applying PI control in current loop, some current overshoot can be favor for pilot success and there are not any current errors in arc welding/cutting process, which is advantage to working stability. Applying Sliding Mode Control in voltage loop for arc welding/cutting power supply can effectively decrease the overshoot of voltage loop without affecting the response time of current loop of arc welding/cutting power supply. Not any overshoot in SMC will decrease the stress of diode, which can decrease the cost of the power supply and reduce the threaten of personal safety. The Sliding Mode Control proposed in this paper has good dynamic performance and easily applied algorithm, and is very suitable for arc welding/cutting power supply which requires good dynamic performance for the control system. This paper provides a new idea to the control of arc welding/cutting power supply.

6. References

- J. G. Cho, J. A. Sabate, G. C. Hua, "Zero-voltage and zero-current switching full bridge PWM converter for high-power applications," in *IEEE Transactions on Power Electronics*, vol. 11, no. 4, pp. 622-628, 1996.
- Y. He and F. L. Luo, "Study of Sliding Mode Control for DC-DC Converter," in *International Conference on Power System Technology*, pp. 1969-1174, 2004.
- S. Arulselvi, A. Biju and G. Uma, "Design and Simulation of Fuzzy Logic Controller for a Constant Frequency Quasi-Resonant DC-DC Converter," in *IEEE ICISIP*, PP. 472-476, 2004.
- X. B. Ruan, Y. G. Yan, "The Soft Switching Technology of PWM DC-DC Full Bridge Converters," in *Beijing: Science Press*, 2001.
- G. R. Zhu, Z. Liu, X. Li, S. X. Duan and Y. Kang, "The multi-functional arc welding cutting inverter based on PS-FB-ZVZCS," in *IEEE Conference in Industrial Electronics and Applications*, pp.1912-1916, 2007.
- Y. T. Zheng, S. S. Huang, "Arc Welding Power Source," in *Beijing: China Machine Press*, 2004.
- G. R. Zhu, Z. Liu, X. Li, S. X. Duan, Y. Kang and J. Chen, "The Digital Multi-functional Arc Welding/Cutting Inverter Based on ZVS," in *International Power Engineering Conference, IPEC2007*.
- L. G. Shiau, J. L. Lin, "Direct and indirect SMC control schemes for DC-DC switching converters," in *Proceedings of the 36th SICE Annual Conference*, pp. 1289-1294, 1997.
- T.I.TI, "TMS320F/C240 DSP Controllers Reference Guide," *Texas Instruments Incorporated*, vol. 6, pp. 2-95, 2000.
- E. S. Kim, T. J. Kim, Y. B. Byun, T. G. Koo, Y. H. Kim, "High power full bridge DC/DC converter using digital-to-phase-shift PWM circuit," in *Power Electronics Specialists Conference*, vol. 1, pp. 17-21, 2001.

H. Q. Ben, S. Y. Yang, S. B. Yuan, J. B. Zhao, "Application research on ZVZCS full-bridge converter technique," in *China Welding Transaction*, vol. 14, no. 2, pp. 113-116, 2005.

IntechOpen

IntechOpen



Sliding Mode Control

Edited by Prof. Andrzej Bartoszewicz

ISBN 978-953-307-162-6

Hard cover, 544 pages

Publisher InTech

Published online 11, April, 2011

Published in print edition April, 2011

The main objective of this monograph is to present a broad range of well worked out, recent application studies as well as theoretical contributions in the field of sliding mode control system analysis and design. The contributions presented here include new theoretical developments as well as successful applications of variable structure controllers primarily in the field of power electronics, electric drives and motion steering systems. They enrich the current state of the art, and motivate and encourage new ideas and solutions in the sliding mode control area.

How to reference

In order to correctly reference this scholarly work, feel free to copy and paste the following:

Guo-Rong Zhu and Yong Kang (2011). The Synthetic Control of SMC and PI for Arc Welding/cutting Power Supply, Sliding Mode Control, Prof. Andrzej Bartoszewicz (Ed.), ISBN: 978-953-307-162-6, InTech, Available from: <http://www.intechopen.com/books/sliding-mode-control/the-synthetic-control-of-smc-and-pi-for-arc-welding-cutting-power-supply>

INTECH
open science | open minds

InTech Europe

University Campus STeP Ri
Slavka Krautzeka 83/A
51000 Rijeka, Croatia
Phone: +385 (51) 770 447
Fax: +385 (51) 686 166
www.intechopen.com

InTech China

Unit 405, Office Block, Hotel Equatorial Shanghai
No.65, Yan An Road (West), Shanghai, 200040, China
中国上海市延安西路65号上海国际贵都大饭店办公楼405单元
Phone: +86-21-62489820
Fax: +86-21-62489821

© 2011 The Author(s). Licensee IntechOpen. This chapter is distributed under the terms of the [Creative Commons Attribution-NonCommercial-ShareAlike-3.0 License](#), which permits use, distribution and reproduction for non-commercial purposes, provided the original is properly cited and derivative works building on this content are distributed under the same license.

IntechOpen

IntechOpen