

# We are IntechOpen, the world's leading publisher of Open Access books Built by scientists, for scientists

4,400

Open access books available

117,000

International authors and editors

130M

Downloads

Our authors are among the

154

Countries delivered to

TOP 1%

most cited scientists

12.2%

Contributors from top 500 universities



WEB OF SCIENCE™

Selection of our books indexed in the Book Citation Index  
in Web of Science™ Core Collection (BKCI)

Interested in publishing with us?  
Contact [book.department@intechopen.com](mailto:book.department@intechopen.com)

Numbers displayed above are based on latest data collected.  
For more information visit [www.intechopen.com](http://www.intechopen.com)



# Robust Controller Design: New Approaches in the Time and the Frequency Domains

Vojtech Veselý, Danica Rosinová and Alena Kozáková  
*Slovak University of Technology  
Slovak Republic*

## 1. Introduction

Robust stability and robust control belong to fundamental problems in control theory and practice; various approaches have been proposed to cope with uncertainties that always appear in real plants as a result of identification / modelling errors, e.g. due to linearization and approximation, etc. A control system is robust if it is insensitive to differences between the actual plant and its model used to design the controller. To deal with an uncertain plant a suitable uncertainty model is to be selected and instead of a single model, behaviour of a whole class of models is to be considered. Robust control theory provides analysis and design approaches based upon an incomplete description of the controlled process applicable in the areas of non-linear and time-varying processes, including multi input – multi output (MIMO) dynamic systems.

MIMO systems usually arise as interconnection of a finite number of subsystems, and in general, multivariable centralized controllers are used to control them. However, practical reasons often make restrictions on controller structure necessary or reasonable. In an extreme case, the controller is split into several local feedbacks and becomes a decentralized controller. Compared to centralized full-controller systems such a control structure brings about certain performance deterioration; however, this drawback is weighted against important benefits, e.g. hardware, operation and design simplicity, and reliability improvement. Robust approach is one of useful ways to address the decentralized control problem (Boyd et al., 1994; Henrion et al., 2002; de Oliveira et al., 1999; Gyurkovics & Takacs, 2000; Ming Ge et al., 2002; Skogestad & Postlethwaite, 2005; Kozáková and Veselý, 2008; Kozáková et al., 2009a).

In this chapter two robust controller design approaches are presented: in the time domain the approach based on Linear (Bilinear) matrix inequality (LMI, BMI), and in the frequency domain the recently developed Equivalent Subsystem Method (ESM) (Kozáková et al., 2009b). As proportional-integral-derivative (PID) controllers are the most widely used in industrial control systems, this chapter focuses on the time- and frequency domain PID controller design techniques resulting from both approaches.

The development of Linear Matrix Inequality (LMI) computational techniques has provided an efficient tool to solve a large set of convex problems in polynomial time (e.g. Boyd et al., 1994). Significant effort has been therefore made to formulate crucial control problems in

algebraic way (e.g. Skelton et al., 1998), so that the numerical LMI solution can be employed. This approach is advantageously used in solving control problems for linear systems with convex (affine or polytopic) uncertainty domain. However, many important problems in linear control design, such as decentralized control, simultaneous static output feedback (SOF) or more generally - structured linear control problems have been proven as NP hard (Blondel & Tsitsiklis, 1997). Though there exist solvers for bilinear matrix inequalities (BMI), suitable to solve e.g. SOF, they are numerically demanding and restricted to problems of small dimensions. Intensive research has been devoted to overcome nonconvexity and transform the nonconvex or NP-hard problem into convex optimisation problem in LMI framework. Various techniques have been developed using inner or outer convex approximations of the respective nonconvex domains. The common tool in both inner and outer approximation is the use of linearization or convexification. In (Han & Skelton, 2003; de Oliveira et al., 1999), the general convexifying algorithm for the nonconvex function together with potential convexifying functions for both continuous and discrete-time case have been proposed. Linearization approach for continuous and discrete-time system design was independently used in (Rosinová & Veselý, 2003; Veselý, 2003).

When designing a (PID) controller, the derivative part of the controller causes difficulties when uncertainties are considered. In multivariable PID control schemes using LMI developed recently (Zheng et al., 2002), the incorporation of the derivative part requires inversion of the respective matrix, which does not allow including uncertainties. Another way to cope with the derivative part is to assume the special case when output and its derivative are state variables, robust PID controller for first and second order SISO systems are proposed for this case in (Ming Ge et al., 2002).

In Section 2, the state space approach to the design of (decentralized or multi-loop) PID robust controllers is proposed for linear uncertain system with guaranteed cost using a new quadratic cost function. The major contribution is in considering the derivative part in robust control framework. The resulting matrix inequality can be solved either using BMI solver, or using linearization approach and following LMI solution.

The frequency domain design techniques have probably been the most popular among the practitioners due to their insightfulness and link to the classical control theory. In combination with the robust approach they provide a powerful engineering tool for control system analysis and synthesis. An important field of their implementation is control of MIMO systems, in particular the decentralized control (DC) due to simplicity of hardware and information processing algorithms. The DC design proceeds in two main steps: 1) selection of a suitable control configuration (pairing inputs with outputs); 2) design of local controllers for individual subsystems. There are two main approaches applicable in Step 2: sequential (dependent) design, and independent design. When using *sequential design* local controllers are designed sequentially as a series controller, hence information about "lower level" controllers is directly used as more loops are closed. Main drawbacks are lack of failure tolerance when lower level controllers fail, strong dependence of performance on the loop closing order, and a trial-and-error design process.

According to the *independent design*, local controllers are designed to provide stability of each individual loop without considering interactions with other subsystems. The effect of interactions is assessed and transformed into bounds for individual designs to guarantee stability and a desired performance of the full system. Main advantages are direct design of local controllers with no need for trial and error; the limitation consists in that information

about controllers in other loops is not exploited, therefore obtained stability and performance conditions are only sufficient and thus potentially conservative.

Section 3 presents a frequency domain robust decentralized controller design technique applicable for uncertain systems described by a set of transfer function matrices. The core of the technique is the Equivalent Subsystems Method - a Nyquist-based DC design method guaranteeing performance of the full system (Kozáková et al., 2009a; 2009b). To guarantee specified performance (including stability), the effect of interactions is assessed using a selected characteristic locus of the matrix of interactions further used to reshape frequency responses of decoupled subsystems thus generating so-called equivalent subsystems. Local controllers of equivalent subsystems independently tuned to guarantee specified performance measure value in each of them constitute the decentralized (diagonal) controller; when applied to real subsystems, the resulting controller guarantees the same performance measure value for the full system. To guarantee robust stability over the specified operating range of the plant, the  $M-\Delta$  stability conditions are used (Skogestad & Postlethwaite, 2005; Kozáková et al., 2009a, 2009b). Two versions of the robust DC design methodology have been developed: a the two-stage version (Kozáková & Veselý, 2009; Kozáková et al. 2009a), where robust stability is achieved by additional redesign of the DC parameters; in the direct version, robust stability conditions are integrated in the design of local controllers for equivalent subsystems. Unlike standard robust approaches, the proposed technique allows considering full nominal model thus reducing conservatism of robust stability conditions. Further conservatism relaxing is achieved if the additive affine type uncertainty description and the related  $M_{af}-Q$  stability conditions are used (Kozáková & Veselý, 2007; 2008).

In the sequel,  $X > 0$  denotes positive definite matrix;  $*$  in matrices denotes the respective transposed term to make the matrix symmetric;  $I$  denotes identity matrix and  $0$  denotes zero matrix of the respective dimensions.

## 2. Robust PID controller design in the time domain

In this section the PID control problem formulation via LMI is presented that is appropriate for polytopic uncertain systems. Robust PID control scheme is then proposed for structured control gain matrix, thus enabling decentralized PID control design.

### 2.1 Problem formulation and preliminaries

Consider the class of linear affine uncertain time-invariant systems described as:

$$\begin{aligned}\delta x(t) &= (A + \delta A)x(t) + (B + \delta B)u(t) \\ y(t) &= Cx(t)\end{aligned}\tag{1}$$

where

$$\begin{aligned}\delta x(t) &= \dot{x}(t) \quad \text{for continuous-time system} \\ \delta x(t) &= x(t+1) \quad \text{for discrete-time system}\end{aligned}$$

$x(t) \in R^n, u(t) \in R^m, y(t) \in R^l$  are state, control and output vectors respectively;  $A, B, C$  are known constant matrices of the respective dimensions corresponding to the nominal system,  $\delta A, \delta B$  are matrices of uncertainties of the respective dimensions. The affine uncertainties are assumed

$$\delta A(t) = \sum_{j=1}^p \gamma_j \tilde{A}_j, \delta B(t) = \sum_{j=1}^p \gamma_j \tilde{B}_j \quad (2)$$

where  $\underline{\gamma}_j \leq \gamma_j \leq \bar{\gamma}_j$  are unknown uncertainty parameters;  $\tilde{A}_j, \tilde{B}_j, j = 1, 2, \dots, p$  are constant matrices of uncertainties of the respective dimensions and structure. The uncertainty domain for a system described in (1), (2) can be equivalently described by a polytopic model given by its vertices

$$\{(A_1, B_1, C), (A_2, B_2, C), \dots, (A_N, B_N, C)\}, N = 2^p \quad (3)$$

The (decentralized) feedback control law is considered in the form

$$u(t) = FCx(t) \quad (4)$$

where  $F$  is an output feedback gain matrix. The uncertain closed-loop polytopic system is then

$$\delta x(t) = A_C(\alpha)x(t) \quad (5)$$

where

$$A_C(\alpha) \in \left\{ \sum_{i=1}^N \alpha_i A_{Ci}, \sum_{i=1}^N \alpha_i = 1, \alpha_i \geq 0 \right\}, \quad (6)$$

$$A_{Ci} = A_i + B_i FC.$$

To assess the performance, a quadratic cost function known from LQ theory is frequently used. In practice, the response rate or overshoot are often limited, therefore we include the additional derivative term for state variable into the cost function to damp the oscillations and limit the response rate.

$$J_c = \int_0^{\infty} [x(t)^T Qx(t) + u(t)^T Ru(t) + \delta x(t)^T S\delta x(t)] dt \text{ for a continuous-time and} \quad (7)$$

$$J_d = \sum_{k=0}^{\infty} [x(k)^T Qx(k) + u(k)^T Ru(k) + \delta x(k)^T S\delta x(k)] \text{ for a discrete-time system} \quad (8)$$

where  $Q, S \in R^{n \times n}, R \in R^{m \times m}$  are symmetric positive definite matrices. The concept of *guaranteed cost control* is used in a standard way: let there exist a feedback gain matrix  $F_0$  and a constant  $J_0$  such that

$$J \leq J_0 \quad (9)$$

holds for the closed loop system (5), (6). Then the respective control (4) is called the *guaranteed cost control* and the value of  $J_0$  is the *guaranteed cost*.

The main aim of Section 2 of this chapter is to solve the next problem.

#### *Problem 2.1*

Find a (decentralized) robust PID control design algorithm that stabilizes the uncertain system (1) with guaranteed cost with respect to the cost function (7) or (8).

We start with basic notions concerning Lyapunov stability and convexifying functions. In the following we use D-stability concept (Henrion et al., 2002) to receive the respective stability conditions in more general form.

*Definition 2.1 (D-stability)*

Consider the D-domain in the complex plain defined as

$$D = \{s \text{ is complex number} : \begin{bmatrix} 1 \\ s \end{bmatrix}^* \begin{bmatrix} r_{11} & r_{12} \\ r_{12}^* & r_{22} \end{bmatrix} \begin{bmatrix} 1 \\ s \end{bmatrix} < 0\}.$$

The considered linear system (1) is D-stable if and only if all its poles lie in the D-domain. (For simplicity, we use in Def. 2.1 scalar values of parameters  $r_{ij}$ , in general the stability domain can be defined using matrix values of parameters  $r_{ij}$  with the respective dimensions.) The standard choice of  $r_{ij}$  is  $r_{11} = 0, r_{12} = 1, r_{22} = 0$  for a continuous-time system;  $r_{11} = -1, r_{12} = 0, r_{22} = 1$  for a discrete-time system, corresponding to open left half plane and unit circle respectively.

The *quadratic D-stability* of uncertain system is equivalent to the existence of one Lyapunov function for the whole uncertainty set.

*Definition 2.2 (Quadratic D-stability)*

The uncertain system (5) is quadratically D-stable if and only if there exists a symmetric positive definite matrix  $P$  such that

$$r_{12}PA_C(\alpha) + r_{12}^*A_C^T(\alpha)P + r_{11}P + r_{22}A_C^T(\alpha)PA_C(\alpha) < 0 \quad (10)$$

To obtain less conservative results than using quadratic stability, a robust stability notion is considered based on the parameter dependent Lyapunov function (PDLF) defined as

$$P(\alpha) = \sum_{i=1}^N \alpha_i P_i \quad \text{where } P_i = P_i^T > 0 \quad (11)$$

*Definition 2.3 (deOliveira et al., 1999)*

System (5) is *robustly D-stable* in the convex uncertainty domain (6) with parameter-dependent Lyapunov function (11) if and only if there exists a matrix  $P(\alpha) = P(\alpha)^T > 0$  such that

$$r_{12}P(\alpha)A_C(\alpha) + r_{12}^*A_C^T(\alpha)P(\alpha) + r_{11}P(\alpha) + r_{22}A_C^T(\alpha)P(\alpha)A_C(\alpha) < 0 \quad (12)$$

for all  $\alpha$  such that  $A_C(\alpha)$  is given by (6).

Now recall the sufficient robust D-stability condition proposed in (Peaucelle et al., 2000), proven as not too conservative (Grman et al., 2005).

*Lemma 2.1*

If there exist matrices  $E \in R^{n \times n}, G \in R^{n \times n}$  and  $N$  symmetric positive definite matrices  $P_i \in R^{n \times n}$  such that for all  $i = 1, \dots, N$ :

$$\begin{bmatrix} r_{11}P_i + A_{Ci}^T E^T + EA_{Ci} & r_{12}P_i - E + A_{Ci}^T G \\ r_{12}^*P_i - E^T + G^T A_{Ci} & r_{22}P_i - (G + G^T) \end{bmatrix} < 0 \quad (13)$$

then uncertain system (5) is robustly D-stable.



Note that matrices  $E$  and  $G$  are not restricted to any special form; they were included to relax the conservatism of the sufficient condition. To transform nonconvex problem of structured control (e.g. output feedback, or decentralized control) into convex form, the convexifying (linearizing) function can be used (Han&Skelton, 2003; deOliveira et al., 2000; Rosinová&Veselý, 2003; Veselý, 2003). The respective potential convexifying function for  $X^{-1}$  and  $XWX$  has been proposed in the linearizing form:

- the linearization of  $X^{-1} \in R^{n \times n}$  about the value  $X_k > 0$  is

$$\Phi(X^{-1}, X_k) = X_k^{-1} - X_k^{-1}(X - X_k)X_k^{-1} \quad (14)$$

- the linearization of  $XWX \in R^{n \times n}$  about  $X_k$  is

$$\Psi(XWX, X_k) = -X_kWX_k + XWX_k + X_kWX \quad (15)$$

Both functions defined in (14) and (15) meet one of the basic requirements on convexifying function: to be equal to the original nonconvex term if and only if  $X_k = X$ . However, the question how to choose the appropriate nice convexifying function remains still open.

## 2.2 Robust optimal controller design

In this section the new design algorithm for optimal control with guaranteed cost is developed using parameter dependent Lyapunov function and convexifying approach employing iterative procedure. The proposed control design approach is based on sufficient stability condition from Lemma 2.1. The next theorem provides the new form of robust stability condition for linear uncertain system with guaranteed cost.

*Theorem 2.1*

Consider uncertain linear system (1), (2) with static output feedback (4) and cost function (7) or (8). The following statements are equivalent:

- Closed loop uncertain system (5) is robustly D-stable with PDLF (11) and guaranteed cost with respect to cost function (7) or (8):  $J \leq J_0 = x^T(0)P(\alpha)x(0)$ .
- There exist matrices  $P(\alpha) > 0$  defined by (11) such that

$$\begin{aligned} & r_{12}P(\alpha)A_C(\alpha) + r_{12}^*A_C^T(\alpha)P(\alpha) + r_{11}P(\alpha) + r_{22}A_C^T(\alpha)P(\alpha)A_C(\alpha) + \\ & + Q + C^T F^T R F C + A_C^T(\alpha)S A_C(\alpha) < 0 \end{aligned} \quad (16)$$

- There exist matrices  $P(\alpha) > 0$  defined by (11) and matrices  $H, G$  and  $F$  of the respective dimensions such that

$$\begin{bmatrix} r_{11}P(\alpha) + A_{Ci}^T(\alpha)H^T + HA_{Ci}(\alpha) + Q + C^T F^T R F C & * \\ r_{12}^*P(\alpha) - H^T + G^T A_{Ci}(\alpha) & r_{22}P(\alpha) - (G + G^T) + S \end{bmatrix} < 0 \quad (17)$$

$A_{Ci} = (A_i + B_i F C)$  denotes the  $i$ -th closed loop system vertex. Matrix  $F$  is the guaranteed cost control gain for the uncertain system (5), (6).

*Proof.* For brevity the detail steps of the proof are omitted where standard tools are applied. (i)  $\Leftrightarrow$  (ii): the proof is analogous to that in (Rosinová, Veselý, Kučera, 2003). The (ii)  $\Rightarrow$  (i) is shown by taking  $V(t) = x(t)P(\alpha)x(t)$  as a candidate Lyapunov function for (5) and writing  $\delta V(t)$ , where

$$\begin{aligned}\delta V(t) &= \dot{V}(t) && \text{for continuous-time system} \\ \delta V(t) &= V(t+1) - V(t) && \text{for discrete-time system}\end{aligned}$$

$$\delta V(t) = r_{12}^* \delta x(t)^T P(\alpha) x(t) + r_{12} x(t)^T P(\alpha) \delta x(t) + r_{11} x(t)^T P(\alpha) x(t) + r_{22} \delta x(t)^T P(\alpha) \delta x(t) \quad (18)$$

Substituting for  $\delta x$  from (5) to (18) and comparing with (16) provides  $D$ -stability of the considered system when the latter inequality holds. The guaranteed cost can be proved by summing or integrating both sides of the following inequality for  $t$  from 0 to  $\infty$ :

$$\delta V(t) < -x(t)^T [Q + C^T F^T R F C + A_C^T(\alpha) S A_C(\alpha)] x(t)$$

The (i)  $\Rightarrow$  (ii) can be proved by contradiction.

(ii)  $\Leftrightarrow$  (iii): The proof follows the same steps to the proof of Lemma 2.1: (iii)  $\Rightarrow$  (ii) is proved in standard way multiplying both sides of (17) by the full rank matrix (equivalent transformation):

$$\begin{bmatrix} I & A_C^T(\alpha) \end{bmatrix} \{l.h.s.(17)\} \begin{bmatrix} I \\ A_C(\alpha) \end{bmatrix} < 0.$$

(ii)  $\Rightarrow$  (iii) follows from applying a Schur complement to (16) rewritten as

$$r_{12} P(\alpha) A_C(\alpha) + r_{12}^* A_C^T(\alpha) P(\alpha) + Q + C^T F^T R F C + r_{11} P(\alpha) + A_C^T(\alpha) [r_{22} P(\alpha) + S] A_C(\alpha) < 0$$

Therefore  $\begin{bmatrix} X_{11} & X_{12} \\ X_{12}^T & X_{22} \end{bmatrix} < 0$  where

$$\begin{aligned}X_{11} &= r_{11} P(\alpha) + r_{12} P(\alpha) A_C(\alpha) + r_{12}^* A_C^T(\alpha) P(\alpha) + Q + C^T F^T R F C \\ X_{12} &= A_C^T(\alpha) [r_{22} P(\alpha) + S] \\ X_{22} &= -[r_{22} P(\alpha) + S]\end{aligned}$$

which for  $H = r_{12} P(\alpha)$ ,  $G = [r_{22} P(\alpha) + S]$  gives (17).

The proposed guaranteed cost control design is based on the robust stability condition (17). Since the matrix inequality (17) is not LMI when both  $P(\alpha)$  and  $F$  are to be found, we use the inner approximation for the continuous time system applying linearization formula (15) together with using the respective quadratic forms to obtain LMI formulation, which is then solved by iterative procedure.

### 2.3 PID robust controller design for continuous-time systems

Control algorithm for PID is considered as

$$u(t) = K_p y(t) + K_I \int_0^t y(t) dt + F_d C_d \dot{x}(t) \quad (19)$$

The proportional and integral term can be included into the state vector in the common way defining the auxiliary state  $z = \int_0^t y(t)$ , i.e.  $\dot{z}(t) = y(t) = Cx(t)$ . Then the closed-loop system for PI part of the controller is



$$\dot{x}_n = \begin{bmatrix} \dot{x} \\ \dot{z} \end{bmatrix} = \begin{bmatrix} A + \delta A & 0 \\ C & 0 \end{bmatrix} \begin{bmatrix} x \\ z \end{bmatrix} + \begin{bmatrix} B + \delta B \\ 0 \end{bmatrix} u(t) \quad \text{and} \quad u(t) = FCx(t) + F_d C_d \dot{x}(t) \quad (20)$$

where  $FCx(t)$  and  $F_d C_d \dot{x}(t)$  correspond respectively to the PI and D term of PID controller. The resulting closed loop system with PID controller (19) is then

$$\dot{x}_n(t) = A_C(\alpha)x_n(t) + B(\alpha)[F_d C_d \quad 0]\dot{x}_n(t) \quad (21)$$

where the PI controller term is included in  $A_C(\alpha)$ . (For brevity we omit the argument  $t$ .) To simplify the denotation, in the following we consider PD controller (which is equivalent to the assumption, that the I term of PID controller has been already included into the system dynamics in the above outlined way) and the closed loop is described by

$$\dot{x}(t) = A_C(\alpha)x(t) + B(\alpha)F_d C_d \dot{x}(t) \quad (22)$$

Let us consider the following performance index

$$J_s = \int_0^{\infty} \begin{bmatrix} x & \dot{x} \end{bmatrix}^T \begin{bmatrix} Q + C^T F^T R F C & 0 \\ 0 & S \end{bmatrix} \begin{bmatrix} x \\ \dot{x} \end{bmatrix} dt \quad (23)$$

which formally corresponds to (7). Then for Lyapunov function (11) we have the necessary and sufficient condition for robust stability with guaranteed cost in the form (16), which for continuous time system can be rewritten as:

$$\begin{bmatrix} x & \dot{x} \end{bmatrix}^T \begin{bmatrix} Q + C^T F^T R F C & P(\alpha) \\ P(\alpha) & S \end{bmatrix} \begin{bmatrix} x \\ \dot{x} \end{bmatrix} < 0 \quad (24)$$

The main result on robust PID control stabilization is summarized in the next theorem.

#### Theorem 2.2

Consider a continuous uncertain linear system (1), (2) with PID controller (19) and cost function (23). The following statements are equivalent:

- i Closed loop system (21) is robustly D-stable with PDLF (11) and guaranteed cost with respect to cost function (23):  $J \leq J_0 = x^T(0)P(\alpha)x(0)$ .
- ii There exist matrices  $P(\alpha) > 0$  defined by (11), and  $H, G, F$  and  $F_d$  of the respective dimensions such that

$$\begin{bmatrix} A_{Ci}^T H^T + H A_{Ci} + Q + C^T F^T R F C & * \\ P_i - M_{di}^T H + G^T A_{Ci} & -M_{di}^T G - G^T M_{di} + S \end{bmatrix} < 0 \quad (25)$$

$A_{Ci} = (A_i + B_i F C)$  denotes the  $i$ -th closed loop system vertex,  $M_{di}$  includes the derivative part of the PID controller:  $M_{di} = I - B_i F_d C_d$ .

*Proof.* Owing to (22) for any matrices  $H$  and  $G$ :

$$\begin{aligned} & (-x^T H - \dot{x}^T G^T)(\dot{x} - A_C(\alpha)x - B(\alpha)F_d C_d \dot{x}) + \\ & + (\dot{x} - A_C(\alpha)x - B(\alpha)F_d C_d \dot{x})^T (H^T x - G \dot{x}) = 0 \end{aligned} \quad (26)$$

Summing up the l.h.s of (26) and (24) and taking into consideration linearity w.r.t.  $\alpha$  we get condition (25).

Theorem 2.2 provides the robust stability condition for the linear uncertain system with PID controller. Notice that the derivative term does not appear in the matrix inversion and allows including the uncertainty in control matrix  $B$  into the stability condition.

Considering PID control design, there are unknown matrices  $H$ ,  $G$ ,  $F$  and  $F_d$  to be solved from (25). (Recall that  $A_{Ci} = (A_i + B_iFC)$ ,  $M_{di} = I - B_iF_dC_d$ .) Then, inequality (25) is bilinear with respect to unknown matrices and can be solved either by BMI solver, or by linearization approach using (15) to cope with the respective unknown matrices products. For the latter case the PID iterative control design algorithm based on LMI (4x4 matrix) has been proposed. The resulting closed loop system with PD controller is

$$\dot{x}(t) = (I - B_iF_dC_d)^{-1} (A_i + B_iFC)x(t), \quad i=1, \dots, N \quad (27)$$

The extension of the proposed algorithm to decentralized control design is straightforward since the respective  $F$  and  $F_d$  matrices are assumed as being of the prescribed structure, therefore it is enough to prescribe the decentralized structure for both matrices.

#### 2.4 PID robust controller design for discrete-time systems

Control algorithm for discrete-time PID (often denoted as PSD controller) is considered as

$$u(k) = k_p e(k) + k_I \sum_{i=0}^k e(k) + k_D [e(k) - e(k-1)] \quad (28)$$

control error  $e(k) = w - y(k)$ ; discrete time being denoted for clarity as  $k$  instead of  $t$ . PSD description in state space:

$$\begin{aligned} z(k+1) &= \begin{bmatrix} 0 & 1 \\ 0 & 1 \end{bmatrix} z(k) + \begin{bmatrix} 0 \\ 1 \end{bmatrix} e(k) = A_R z(k) + B_R e(k) \\ u(k) &= [k_D \quad k_I - k_D] z(k) + (k_p + k_I + k_D) e(k) \end{aligned} \quad (29)$$

Combining (1) for  $t \approx k$  and (29) the augmented closed loop system is received as

$$\begin{bmatrix} x(k+1) \\ z(k+1) \end{bmatrix} = \begin{bmatrix} A + \delta A & 0 \\ -B_R C & A_R \end{bmatrix} \begin{bmatrix} x(k) \\ z(k) \end{bmatrix} + \begin{bmatrix} B + \delta B \\ 0 \end{bmatrix} [-K_2 \quad K_1] \begin{bmatrix} C & 0 \\ 0 & I \end{bmatrix} \begin{bmatrix} x(k) \\ z(k) \end{bmatrix} \quad (30)$$

where  $K_2 = (k_p + k_I + k_D)$ ,  $K_1 = [k_D \quad k_I - k_D]$ .

Note that there is a significant difference between PID (19) and PSD (28) control design problem: for continuous time PID structure results in closed loop system that is not strictly proper which complicates the controller design, while for discrete time PSD structure, the control design is formulated as static output feedback (SOF) problem therefore the respective techniques to SOF design can be applied.

In this section an algorithm for PSD controller design is proposed. Theorem 2.1 provides the robust stability condition for the linear time varying uncertain system, where a constrained control structure can be assumed: considering  $A_{Ci} = (A_i + B_iFC)$  we have SOF problem formulation which is also the case of discrete time PSD control structure for

$F = [-(k_p + k_I + k_D) \quad k_D \quad k_I - k_D]$  (see (30)); (taking block diagonal structure of feedback matrix gain  $F$  provides decentralized controller). Inequality (17) is LMI for stability analysis for unknown  $H$ ,  $G$  and  $P_i$ , however considering control design, having one more unknown matrix  $F$  in  $A_{Ci} = (A_i + B_i FC)$ , the inequality (17) is no more LMI. Then, to cope with the respective unknown matrix products the inner approximation approach can be used, when the resulting LMI is sufficient for the original one to hold.

The next robust output feedback design method is based on (17) using additional constraint on output feedback matrix and the state feedback control design approach proposed respectively in (Crusius and Trofino, 1999; deOliveira et al., 1999). For stabilizing PSD control design (without considering cost function) we have the following algorithm (taking  $H=0$ ,  $Q=0$ ,  $R=0$ ,  $S=0$ ).

*PSD controller design algorithm*

Solve the following LMI for unknown matrices  $F$ ,  $M$ ,  $G$  and  $P_i$  of appropriate dimensions, the  $P_i$  being symmetric, positive definite,  $M$ ,  $G$  being any matrices with corresponding dimensions:

$$\begin{bmatrix} -P_i & A_i G + B_i K C \\ G^T A_i^T + C^T K^T B_i^T & -G - G^T + P_i + S \end{bmatrix} < 0 \quad (31)$$

$$\begin{aligned} P_i > 0, \quad i = 1, \dots, N \\ M C = C G \end{aligned} \quad (32)$$

Compute the corresponding output feedback gain matrix

$$F = K M^{-1} \quad (33)$$

where  $F = [-(k_{p_i} + k_{I_i} + k_{D_i}) \quad k_{D_i} \quad k_{I_i} - k_{D_i}]$

The algorithm above is quite simple and often provides reasonable results.

## 2.5 Examples

In this subsection the major contribution of the proposed approach: design of robust controller with derivative feedback is illustrated on the examples. The results obtained using the proposed new iterative algorithm based on (25) to design the PD controller are provided and discussed. The impact of matrix  $S$  choice is studied as well. We consider affine models of uncertain system (1), (2) with symmetric uncertainty domain:

$$\underline{\varepsilon}_j = -q, \quad \bar{\varepsilon}_j = q$$

### Example 2.1

Consider the uncertain system (1), (2) where

$$A = \begin{bmatrix} -4.365 & -0.6723 & -0.3363 \\ 7.0880 & -6.5570 & -4.6010 \\ -2.4100 & 7.5840 & -14.3100 \end{bmatrix} \quad B = \begin{bmatrix} 2.3740 & 0.7485 \\ 1.3660 & 3.4440 \\ 0.9461 & -9.6190 \end{bmatrix} \quad C = C_d = \begin{bmatrix} 0 & 1 & 0 \\ 0 & 0 & 1 \end{bmatrix}$$

uncertainty parameter  $q=1$ ; uncertainty matrices

$$\bar{A}_1 = \begin{bmatrix} -0.5608 & 0.8553 & 0.5892 \\ 0.6698 & -1.3750 & -0.9909 \\ 3.1917 & 1.7971 & -2.5887 \end{bmatrix} \quad \bar{B}_1 = \begin{bmatrix} 2.3740 & 0.7485 \\ 1.3660 & 3.4440 \\ 0.9461 & -9.6190 \end{bmatrix}$$

$$\bar{A}_2 = \begin{bmatrix} 0.6698 & -1.3750 & -0.9909 \\ -2.8963 & -1.5292 & 10.5160 \\ -3.5777 & 2.8389 & 1.9087 \end{bmatrix} \quad \bar{B}_2 = \begin{bmatrix} 0.1562 & 0.1306 \\ -0.4958 & 4.0379 \\ -0.0306 & 0.8947 \end{bmatrix}$$

The uncertain system can be described by 4 vertices; corresponding maximal eigenvalues in the vertices of open loop system are respectively:  $-4.0896 \pm 2.1956i$ ;  $-3.9243$ ;  $1.5014$ ;  $-4.9595$ . Notice, that the open loop uncertain system is unstable (positive eigenvalue in the third vertex). The stabilizing optimal PD controller has been designed by solving matrix inequality (25). Optimality is considered in the sense of guaranteed cost w.r.t. cost function (23) with matrices  $R = I_{2 \times 2}$ ,  $Q = 0.001 * I_{3 \times 3}$ . The results summarized in Tab.2.1 indicate the differences between results obtained for different choice of cost matrix  $S$  respective to a derivative of  $x$ .

S	Controller matrices F (proportional part) F <sub>d</sub> (derivative part)	Max eigenvalues in vertices
1e-6 *I	$F = \begin{bmatrix} -1.0567 & -0.5643 \\ -2.1825 & -1.4969 \end{bmatrix}$ $F_d = \begin{bmatrix} -0.3126 & -0.2243 \\ -0.0967 & 0.0330 \end{bmatrix}$	-4.8644 <b>-2.4074</b> $-3.8368 \pm 1.1165 i$ -4.7436
0.1 *I	$F = \begin{bmatrix} -1.0724 & -0.5818 \\ -2.1941 & -1.4642 \end{bmatrix}$ $F_d = \begin{bmatrix} -0.3227 & -0.2186 \\ -0.0969 & 0.0340 \end{bmatrix}$	-4.9546 <b>-2.2211</b> $-3.7823 \pm 1.4723 i$ -4.7751

Table 2.1 PD controllers from Example 2.1.

#### Example 2.2

Consider the uncertain system (1), (2) where

$$A = \begin{bmatrix} -2.9800 & 0.9300 & 0 & -0.0340 \\ -0.9900 & -0.2100 & 0.0350 & -0.0011 \\ 0 & 0 & 0 & 1 \\ 0.3900 & -5.5550 & 0 & -1.8900 \end{bmatrix} \quad B = \begin{bmatrix} -0.0320 \\ 0 \\ 0 \\ -1.6000 \end{bmatrix} \quad C = \begin{bmatrix} 0 & 0 & 1 & 0 \\ 0 & 0 & 0 & 1 \end{bmatrix}$$

$$A = \begin{bmatrix} 0 & 1.5 & 0 & 0 \\ 0 & 0 & 0 & 0 \\ 0 & 0 & 0 & 0 \\ 0 & 0 & 0 & 0 \end{bmatrix} \quad B = \begin{bmatrix} 0 \\ 0 \\ 0 \\ 0 \end{bmatrix}.$$

The results are summarized in Tab.2.2 for  $R = 1, Q = 0.0005 * I_{4 \times 4}$  for various values of cost function matrix  $S$ . As indicated in Tab.2.2, increasing values of  $S$  slow down the response as assumed (max. eigenvalue of closed loop system is shifted to zero).

$S$	$q_{\max}$	Max. eigenvalue of closed loop system
$1e-8 * I$	1.1	-0.1890
$0.1 * I$	1.1	-0.1101
$0.2 * I$	1.1	-0.0863
$0.29 * I$	1.02	-0.0590

Table 2.2 Comparison of closed loop eigenvalues (Example 2.2) for various  $S$ .

### 3. Robust PID controller design in the frequency domain

In this section an original frequency domain robust control design methodology is presented applicable for uncertain systems described by a set of transfer function matrices. A two-stage as well as a direct design procedures were developed, both being based on the Equivalent Subsystems Method - a Nyquist-based decentralized controller design method for stability and guaranteed performance (Kozáková et al., 2009a;2009b), and stability conditions for the  $M-\Delta$  structure (Skogestad & Postlethwaite, 2005; Kozáková et al., 2009a, 2009b). Using the additive affine type uncertainty and related  $M_{af}-Q$  structure stability conditions, it is possible to relax conservatism of the  $M-\Delta$  stability conditions (Kozáková & Veselý, 2007).

#### 3.1 Preliminaries and problem formulation

Consider a MIMO system described by a transfer function matrix  $G(s) \in R^{m \times m}$ , and a controller  $R(s) \in R^{m \times m}$  in the standard feedback configuration (Fig. 1);  $w, u, y, e, d$  are respectively vectors of reference, control, output, control error and disturbance of compatible dimensions. Necessary and sufficient conditions for internal stability of the closed-loop in Fig. 1 are given by the Generalized Nyquist Stability Theorem applied to the closed-loop characteristic polynomial

$$\det F(s) = \det[I + Q(s)] \quad (34)$$

where  $Q(s) = G(s)R(s) \in R^{m \times m}$  is the open-loop transfer function matrix.

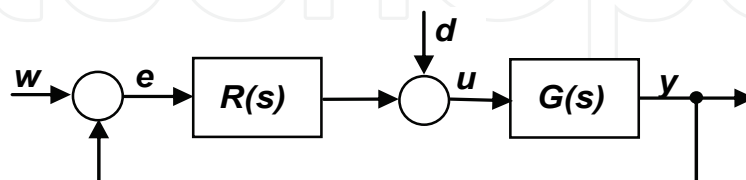

Fig. 1. Standard feedback configuration

The following standard notation is used:  $D$  - the standard Nyquist  $D$ -contour in the complex plane; Nyquist plot of  $g(s)$  - the image of the Nyquist contour under  $g(s)$ ;  $N[k, g(s)]$  - the number of anticlockwise encirclements of the point  $(k, j0)$  by the Nyquist plot of  $g(s)$ . Characteristic functions of  $Q(s)$  are the set of  $m$  algebraic functions  $q_i(s), i = 1, \dots, m$  given as

$$\det[q_i(s)I_m - Q(s)] = 0 \quad i = 1, \dots, m \quad (35)$$

Characteristic loci (CL) are the set of loci in the complex plane traced out by the characteristic functions of  $Q(s)$ ,  $\forall s \in D$ . The closed-loop characteristic polynomial (34) expressed in terms of characteristic functions of  $Q(s)$  reads as follows

$$\det F(s) = \det[I + Q(s)] = \prod_{i=1}^m [1 + q_i(s)] \quad (36)$$

**Theorem 3.1 (Generalized Nyquist Stability Theorem)**

The closed-loop system in Fig. 1 is stable if and only if

$$\begin{aligned} \text{a.} \quad & \det F(s) \neq 0 \quad \forall s \in D \\ \text{b.} \quad & N[0, \det F(s)] = \sum_{i=1}^m N\{0, [1 + q_i(s)]\} = n_q \end{aligned} \quad (37)$$

where  $F(s) = (I + Q(s))$  and  $n_q$  is the number of unstable poles of  $Q(s)$ .

Let the uncertain plant be given as a set  $\Pi$  of  $N$  transfer function matrices

$$\Pi = \{G^k(s)\}, k = 1, 2, \dots, N \text{ where } G^k(s) = \{G_{ij}^k(s)\}_{m \times m} \quad (38)$$

The simplest uncertainty model is the unstructured uncertainty, i.e. a full complex perturbation matrix with the same dimensions as the plant. The set of unstructured perturbations  $D_U$  is defined as follows

$$D_U := \{E(j\omega) : \sigma_{\max}[E(j\omega)] \leq \ell(\omega), \ell(\omega) = \max_k \sigma_{\max}[E(j\omega)]\} \quad (39)$$

where  $\ell(\omega)$  is a scalar weight function on the norm-bounded perturbation  $\Delta(s) \in R^{m \times m}$ ,  $\sigma_{\max}[\Delta(j\omega)] \leq 1$  over given frequency range,  $\sigma_{\max}(\cdot)$  is the maximum singular value of  $(\cdot)$ , i.e.

$$E(j\omega) = \ell(\omega)\Delta(j\omega) \quad (40)$$

For unstructured uncertainty, the set  $\Pi$  can be generated by either additive ( $E_a$ ), multiplicative input ( $E_i$ ) or output ( $E_o$ ) uncertainties, or their inverse counterparts ( $E_{ia}$ ,  $E_{ii}$ ,  $E_{io}$ ), the latter used for uncertainty associated with plant poles located in the closed right half-plane (Skogestad & Postlethwaite, 2005).

Denote  $G(s)$  any member of a set of possible plants  $\Pi_k$ ,  $k = a, i, o, ia, ii, io$ ;  $G_0(s)$  the nominal model used to design the controller, and  $\ell_k(\omega)$  the scalar weight on a normalized perturbation. Individual uncertainty forms generate the following related sets  $\Pi_k$ :

*Additive uncertainty:*

$$\begin{aligned} \Pi_a &:= \{G(s) : G(s) = G_0(s) + E_a(s), E_a(j\omega) \leq \ell_a(\omega)\Delta(j\omega)\} \\ \ell_a(\omega) &= \max_k \sigma_{\max}[G^k(j\omega) - G_0(j\omega)], k = 1, 2, \dots, N \end{aligned} \quad (41)$$



*Multiplicative input uncertainty:*

$$\begin{aligned} \Pi_i &:= \{G(s) : G(s) = G_0(s)[I + E_i(s)], E_i(j\omega) \leq \ell_i(j\omega)\Delta(j\omega)\} \\ \ell_i(\omega) &= \max_k \sigma_{\max}\{G_0^{-1}(j\omega)[G^k(j\omega) - G_0(j\omega)]\}, k = 1, 2, \dots, N \end{aligned} \quad (42)$$

*Multiplicative output uncertainty:*

$$\begin{aligned} \Pi_o &:= \{G(s) : G(s) = [I + E_o(s)]G_0(s), E_o(j\omega) \leq \ell_o(j\omega)\Delta(j\omega)\} \\ \ell_o(\omega) &= \max_k \sigma_{\max}\{[G^k(j\omega) - G_0(j\omega)]G_0^{-1}(j\omega)\}, k = 1, 2, \dots, N \end{aligned} \quad (43)$$

*Inverse additive uncertainty*

$$\begin{aligned} \Pi_{ia} &:= \{G(s) : G(s) = G_0(s)[I - E_{ia}(s)G_0(j\omega)]^{-1}, E_{ia}(j\omega) \leq \ell_{ia}(\omega)\Delta(j\omega)\} \\ \ell_{ia}(\omega) &= \max_k \sigma_{\max}\{[G_0(j\omega)]^{-1} - [G^k(j\omega)]^{-1}\}, k = 1, 2, \dots, N \end{aligned} \quad (44)$$

*Inverse multiplicative input uncertainty*

$$\begin{aligned} \Pi_{ii} &:= \{G(s) : G(s) = G_0(s)[I - E_{ii}(s)]^{-1}, E_{ii}(j\omega) \leq \ell_{ii}(\omega)\Delta(j\omega)\} \\ \ell_{ii}(\omega) &= \max_k \sigma_{\max}\{I - [G^k(j\omega)]^{-1}[G_0(j\omega)]\}, k = 1, 2, \dots, N \end{aligned} \quad (45)$$

*Inverse multiplicative output uncertainty:*

$$\begin{aligned} \Pi_{io} &:= \{G(s) : G(s) = [I - E_{io}(s)]^{-1}G_0(s), E_{io}(j\omega) \leq \ell_{io}(\omega)\Delta(j\omega)\} \\ \ell_{io}(\omega) &= \max_k \sigma_{\max}\{I - [G_0(j\omega)][G^k(j\omega)]^{-1}\}, k = 1, 2, \dots, N \end{aligned} \quad (46)$$

Standard feedback configuration with uncertain plant modelled using any above unstructured uncertainty form can be recast into the  $M-\Delta$  structure (for additive perturbation Fig. 2) where  $M(s)$  is the nominal model and  $\Delta(s) \in \mathbb{R}^{m \times m}$  is the norm-bounded complex perturbation.

If the nominal closed-loop system is stable then  $M(s)$  is stable and  $\Delta(s)$  is a perturbation which can destabilize the system. The following theorem establishes conditions on  $M(s)$  so that it cannot be destabilized by  $\Delta(s)$  (Skogestad & Postlethwaite, 2005).

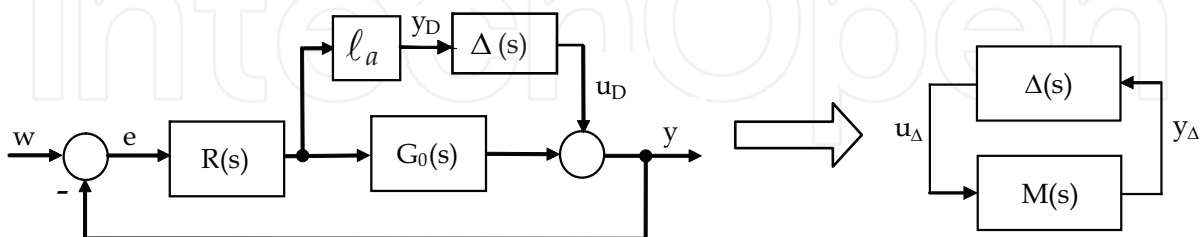

Fig. 2. Standard feedback configuration with unstructured additive uncertainty (left) recast into the  $M-\Delta$  structure (right)

*Theorem 3.2 (Robust stability for unstructured perturbations)*

Assume that the nominal system  $M(s)$  is stable (nominal stability) and the perturbation  $\Delta(s)$  is stable. Then the  $M-\Delta$  system in Fig. 2 is stable for all perturbations  $\Delta(s) : \sigma_{\max}(\Delta) \leq 1$  if and only if

$$\sigma_{\max}[M(j\omega)] < 1, \quad \forall \omega \quad (47)$$

For individual uncertainty forms  $M(s) = \ell_k M_k(s)$ ,  $k = a, i, o, ia, ii, io$ ; the corresponding matrices  $M_k(s)$  are given below (disregarding the negative signs which do not affect resulting robustness condition); commonly, the nominal model  $G_0(s)$  is obtained as a model of mean parameter values.

$$M(s) = \ell_a(s)R(s)[I + G_0(s)R(s)]^{-1} = \ell_a(s)M_a(s) \text{ additive uncertainty} \quad (48)$$

$$M(s) = \ell_i(s)R(s)[I + G_0(s)R(s)]^{-1}G_0(s) = \ell_i(s)M_i(s) \text{ multiplicative input uncertainty} \quad (49)$$

$$M(s) = \ell_o(s)G_0(s)R(s)[I + G_0(s)R(s)]^{-1} = \ell_o(s)M_o(s) \text{ multiplicative output uncertainty} \quad (50)$$

$$M(s) = \ell_{ia}(s)[I + G_0(s)R(s)]^{-1}G_0(s) = \ell_{ia}(s)M_{ia}(s) \text{ inverse additive uncertainty} \quad (51)$$

$$M(s) = \ell_{ii}(s)[I + R(s)G_0(s)]^{-1} = \ell_{ii}(s)M_{ii}(s) \text{ inverse multiplicative input uncertainty} \quad (52)$$

$$M(s) = \ell_{io}(s)[I + G_0(s)R(s)]^{-1} = \ell_{io}(s)M_{io}(s) \text{ inverse multiplicative output uncertainty} \quad (53)$$

Conservatism of the robust stability conditions can be reduced by structuring the unstructured additive perturbation by introducing the *additive affine-type uncertainty*  $E_{af}(s)$  that brings about new way of nominal system computation and robust stability conditions modifiable for the decentralized controller design as (Kozáková & Veselý, 2007; 2008).

$$E_{af}(s) = \sum_{i=1}^p G_i(s)q_i \quad (54)$$

where  $G_i(s) \in R^{m \times m}$ ,  $i=0,1, \dots, p$  are stable matrices,  $p$  is the number of uncertainties defining  $2^p$  polytope vertices that correspond to individual perturbed models;  $q_i$  are polytope parameters. The set  $\Pi_{af}$  generated by the additive affine-type uncertainty ( $E_{af}$ ) is

$$\Pi_{af} := \{G(s) : G(s) = G_0(s) + E_{af}, E_{af} = \sum_{i=1}^p G_i(s)q_i, q_i \in \langle q_{i\min}, q_{i\max} \rangle, q_{i\min} + q_{i\max} = 0\} \quad (55)$$

where  $G_0(s)$  is the „afinne“ nominal model. Put into vector-matrix form, individual perturbed plants (elements of the set  $\Pi_{af}$ ) can be expressed as follows

$$G(s) = G_0(s) + [I_{q_1} \dots I_{q_p}] \begin{bmatrix} G_1(s) \\ \vdots \\ G_p(s) \end{bmatrix} = G_0(s) + QG_u(s) \quad (56)$$

where  $Q = [I_{q_1} \dots I_{q_p}]^T \in R^{m \times (m \times p)}$ ,  $I_{q_i} = q_i I_{m \times m}$ ,  $G_u(s) = [G_1 \dots G_p]^T \in R^{(m \times p) \times m}$ .

Standard feedback configuration with uncertain plant modelled using the additive affine type uncertainty is shown in Fig. 3 (on the left); by analogy with previous cases, it can be recast into the  $M_{af} - Q$  structure in Fig. 3 (on the right) where

$$M_{af} = G_u R (I + G_0 R)^{-1} = G_u (I + R G_0)^{-1} R \quad (57)$$

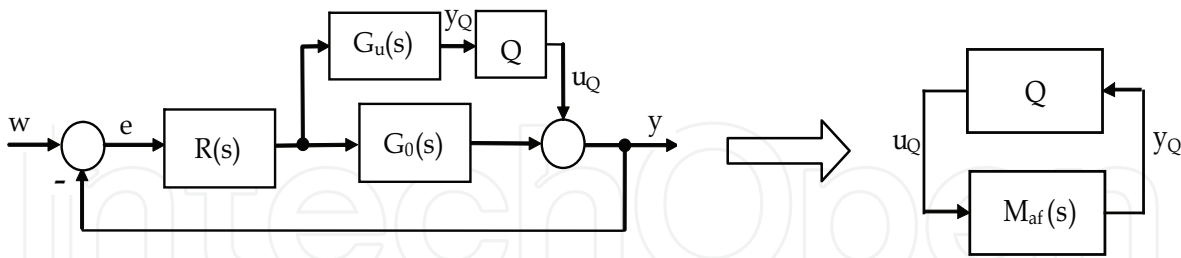

Fig. 3. Standard feedback configuration with unstructured affine-type additive uncertainty (left), recast into the  $M_{af}$ - $Q$  structure (right)

Similarly as for the  $M$ - $\Delta$  system, stability condition of the  $M_{af}$ - $Q$  system is obtained as

$$\sigma_{\max}(M_{af}Q) < 1 \quad (58)$$

Using singular value properties, the small gain theorem, and the assumptions that  $q_0 = |q_{i\min}| = |q_{i\max}|$  and the nominal model  $M_{af}(s)$  is stable, (58) can further be modified to yield the robust stability condition

$$\sigma_{\max}(M_{af})q_0\sqrt{p} < 1 \quad (59)$$

The main aim of Section 3 of this chapter is to solve the next problem.

### Problem 3.1

Consider an uncertain system with  $m$  subsystems given as a set of  $N$  transfer function matrices obtained in  $N$  working points of plant operation, described by a nominal model  $G_0(s)$  and any of the unstructured perturbations (41) – (46) or (55).

Let the nominal model  $G_0(s)$  can be split into the diagonal part representing mathematical models of decoupled subsystems, and the off-diagonal part representing interactions between subsystems

$$G_0(s) = G_d(s) + G_m(s) \quad (60)$$

where

$$G_d(s) = \text{diag}\{G_i(s)\}_{m \times m}, \det G_d(s) \neq 0 \quad \forall s \quad G_m(s) = G_0(s) - G_d(s) \quad (61)$$

A decentralized controller

$$R(s) = \text{diag}\{R_i(s)\}_{m \times m}, \det R(s) \neq 0 \quad \forall s \in D \quad (62)$$

is to be designed with  $R_i(s)$  being transfer function of the  $i$ -th local controller. The designed controller has to guarantee stability over the whole operating range of the plant specified by either (41) – (46) or (55) (robust stability) and a specified performance of the nominal model (nominal performance). To solve the above problem, a frequency domain robust decentralized controller design technique has been developed (Kozáková & Veselý, 2009; Kozáková et al., 2009b); the core of it is the Equivalent Subsystems Method (ESM).

**3.2 Decentralized controller design for performance: equivalent subsystems method**

The Equivalent Subsystems Method (ESM) an original Nyquist-based DC design method for stability and guaranteed performance of the full system. According to it, local controller designs are performed independently for so-called equivalent subsystems that are actually Nyquist plots of decoupled subsystems shaped by a selected characteristic locus of the interactions matrix. Local controllers of equivalent subsystems independently tuned for stability and specified feasible performance constitute the decentralized controller guaranteeing specified performance of the full system. Unlike standard robust approaches, the proposed technique considers full mean parameter value nominal model, thus reducing conservatism of resulting robust stability conditions. In the context of robust decentralized controller design, the Equivalent Subsystems Method (Kozáková et. al., 2009b) is applied to design a decentralized controller for the nominal model  $G_0(s)$  as depicted in Fig. 4.

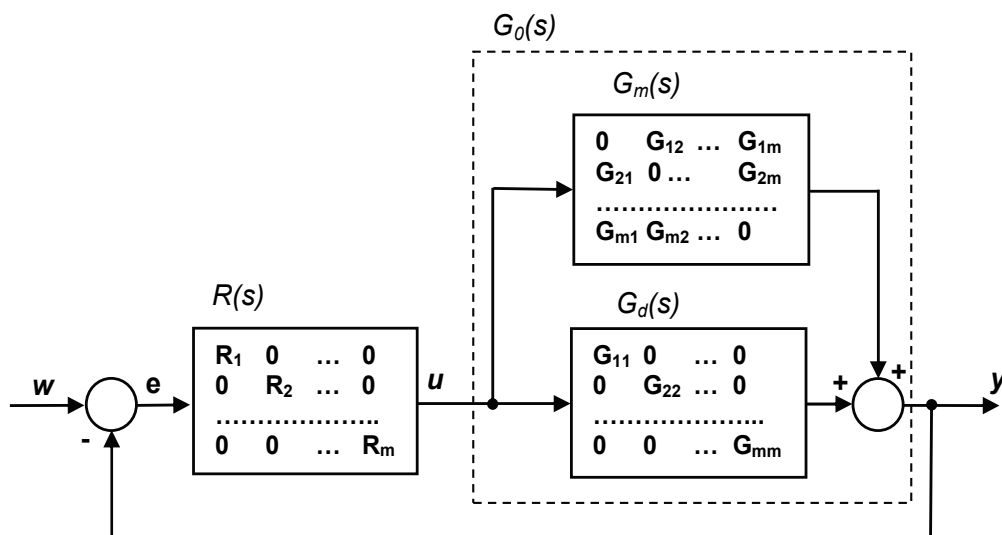

Fig. 4. Standard feedback loop under decentralized controller

The key idea behind the method is factorisation of the closed-loop characteristic polynomial  $\det F(s)$  in terms of the split nominal system (60) under the decentralized controller (62) (existence of  $R^{-1}(s)$  is implied by the assumption (62) that  $\det R(s) \neq 0$ )

$$\det F(s) = \det \{ I + [G_d(s) + G_m(s)]R(s) \} = \det [R^{-1}(s) + G_d(s) + G_m(s)] \det R(s) \tag{63}$$

Denote

$$F_1(s) = R^{-1}(s) + G_d(s) + G_m(s) = P(s) + G_m(s) \tag{64}$$

where

$$P(s) = R^{-1}(s) + G_d(s) \tag{65}$$

is a diagonal matrix  $P(s) = \text{diag}\{p_i(s)\}_{m \times m}$ . Considering (63) and (64), the stability condition (37b) in Theorem 3.1 modifies as follows

$$N\{0, \det[P(s) + G_m(s)]\} + N\{0, \det R(s)\} = n_q \tag{66}$$

and a simple manipulation of (65) yields

$$I + R(s)[G_d(s) - P(s)] = I + R(s)G^{eq}(s) = 0 \quad (67)$$

where

$$G^{eq}(s) = \text{diag}\{G_i^{eq}(s)\}_{m \times m} = \text{diag}\{G_i(s) - p_i(s)\}_{m \times m} \quad i = 1, \dots, m \quad (68)$$

is a diagonal matrix of equivalent subsystems  $G_i^{eq}(s)$ ; on subsystems level, (67) yields  $m$  equivalent characteristic polynomials

$$CLCP_i^{eq}(s) = 1 + R_i(s)G_i^{eq}(s) \quad i = 1, 2, \dots, m \quad (69)$$

Hence, by specifying  $P(s)$  it is possible to affect performance of individual subsystems (including stability) through  $R^{-1}(s)$ . In the context of the independent design philosophy, design parameters  $p_i(s)$ ,  $i = 1, 2, \dots, m$  represent constraints for individual designs. General stability conditions for this case are given in *Corollary 3.1*.

*Corollary 3.1* (Kozáková & Veselý, 2009)

The closed-loop in Fig. 4 comprising the system (60) and the decentralized controller (62) is stable if and only if

1. there exists a diagonal matrix  $P(s) = \text{diag}\{p_i(s)\}_{i=1, \dots, m}$  such that all equivalent subsystems (68) can be stabilized by their related local controllers  $R_i(s)$ , i.e. all equivalent characteristic polynomials  $CLCP_i^{eq}(s) = 1 + R_i(s)G_i^{eq}(s)$ ,  $i = 1, 2, \dots, m$  have roots with  $\text{Re}\{s\} < 0$ ;
2. the following two conditions are met  $\forall s \in D$ :

- a.  $\det[P(s) + G_m(s)] \neq 0$
- b.  $N[0, \det F(s)] = n_q$

(70)

where  $\det F(s) = \det(I + G(s)R(s))$  and  $n_q$  is the number of open loop poles with  $\text{Re}\{s\} > 0$ . In general,  $p_i(s)$  are to be transfer functions, fulfilling conditions of *Corollary 3.1*, and the stability condition resulting from the small gain theory; according to it if both  $P^{-1}(s)$  and  $G_m(s)$  are stable, the necessary and sufficient closed-loop stability condition is

$$\|P(s)^{-1}G_m(s)\| < 1 \quad \text{or} \quad \sigma_{\min}[P(s)] > \sigma_{\max}[G_m(s)] \quad (71)$$

To provide closed-loop stability of the full system under a decentralized controller,  $p_i(s)$ ,  $i = 1, 2, \dots, m$  are to be chosen so as to appropriately cope with the interactions  $G_m(s)$ .

A special choice of  $P(s)$  is addressed in (Kozáková et al. 2009a,b): if considering characteristic functions  $g_i(s)$  of  $G_m(s)$  defined according to (35) for  $i = 1, \dots, m$ , and choosing  $P(s)$  to be diagonal with identical entries equal to any selected characteristic function  $g_k(s)$  of  $[-G_m(s)]$ , where  $k \in \{1, \dots, m\}$  is fixed, i.e.

$$P(s) = -g_k(s)I, \quad k \in \{1, \dots, m\} \text{ is fixed} \quad (72)$$

then substituting (72) in (70a) and violating the well-posedness condition yields

$$\det[P(s) + G_m(s)] = \prod_{i=1}^m [-g_k(s) + g_i(s)] = 0 \quad \forall s \in D \quad (73)$$

In such a case the full closed-loop system is at the limit of instability with equivalent subsystems generated by the selected  $g_k(s)$  according to

$$G_{ik}^{eq}(s) = G_i(s) + g_k(s) \quad i = 1, 2, \dots, m, \quad \forall s \in D \quad (74)$$

Similarly, if choosing  $P(s - \alpha) = -g_k(s - \alpha)I$ ,  $0 \leq \alpha \leq \alpha_m$  where  $\alpha_m$  denotes the maximum feasible degree of stability for the given plant under the decentralized controller  $R(s)$ , then

$$\det F_1(s - \alpha) = \prod_{i=1}^m [-g_k(s - \alpha) + g_i(s - \alpha)] = 0 \quad \forall s \in D \quad (75)$$

Hence, the closed-loop system is stable and has just poles with  $\text{Re}\{s\} \leq -\alpha$ , i.e. its degree of stability is  $\alpha$ . Pertinent equivalent subsystems are generated according to

$$G_{ik}^{eq}(s - \alpha) = G_i(s - \alpha) + g_k(s - \alpha) \quad i = 1, 2, \dots, m \quad (76)$$

To guarantee stability, the following additional condition has to be satisfied simultaneously

$$\det F_{1k} = \prod_{i=1}^m [-g_k(s - \alpha) + g_i(s)] = \prod_{i=1}^m r_{ik}(s) \neq 0 \quad \forall s \in D \quad (77)$$

Simply put, by suitably choosing  $\alpha: 0 \leq \alpha \leq \alpha_m$  to generate  $P(s - \alpha)$  it is possible to guarantee performance under the decentralized controller in terms of the degree of stability  $\alpha$ . Lemma 3.1 provides necessary and sufficient stability conditions for the closed-loop in Fig. 4 and conditions for guaranteed performance in terms of the degree of stability.

*Definition 3.1* (Proper characteristic locus)

The characteristic locus  $g_k(s - \alpha)$  of  $G_m(s - \alpha)$ , where fixed  $k \in \{1, \dots, m\}$  and  $\alpha > 0$ , is called *proper characteristic locus* if it satisfies conditions (73), (75) and (77). The set of all proper characteristic loci of a plant is denoted  $P_S$ .

*Lemma 3.1*

The closed-loop in Fig. 4 comprising the system (60) and the decentralized controller (62) is stable if and only if the following conditions are satisfied  $\forall s \in D$ ,  $\alpha \geq 0$  and fixed  $k \in \{1, \dots, m\}$ :

1.  $g_k(s - \alpha) \in P_S$
2. all equivalent characteristic polynomials (69) have roots with  $\text{Re}s \leq -\alpha$ ;
3.  $N[0, \det F(s - \alpha)] = n_{q\alpha}$

where  $F(s - \alpha) = I + G(s - \alpha)R(s - \alpha)$ ;  $n_{q\alpha}$  is the number of open loop poles with  $\text{Re}\{s\} > -\alpha$ .

Lemma 3.1 shows that local controllers independently tuned for stability and a specified (feasible) degree of stability of equivalent subsystems constitute the decentralized controller guaranteeing the same degree of stability for the full system. The design technique resulting from Corollary 3.1 enables to design local controllers of equivalent subsystems using any SISO frequency-domain design method, e.g. the Neymark D-partition method (Kozáková et al. 2009b), standard Bode diagram design etc. If considering other performance measures in the ESM, the design proceeds according to Corollary 3.1 with  $P(s)$  and  $G_{ik}^{eq}(s) = G_i(s) + g_k(s)$ ,  $i = 1, 2, \dots, m$  generated according to (72) and (74), respectively.



According to the latest results, guaranteed performance in terms of maximum overshoot is achieved by applying Bode diagram design for specified phase margin in equivalent subsystems. This approach is addressed in the next subsection.

### 3.3 Robust decentralized controller design

The presented frequency domain robust decentralized controller design technique is applicable for uncertain systems described as a set of transfer function matrices. The basic steps are:

1. *Modelling the uncertain system*

This step includes choice of the nominal model and modelling uncertainty using any unstructured uncertainty (41)-(46) or (55). The nominal model can be calculated either as the mean value parameter model (Skogestad & Postlethwaite, 2005), or the "affine" model, obtained within the procedure for calculating the affine-type additive uncertainty (Kozáková & Veselý, 2007; 2008). Unlike the standard robust approach to decentralized control design which considers diagonal model as the nominal one (interactions are included in the uncertainty), the ESM method applied in the design for nominal performance allows to consider the *full* nominal model.

2. *Guaranteeing nominal stability and performance*

The ESM method is used to design a decentralized controller (62) guaranteeing stability and specified performance of the nominal model (nominal stability, nominal performance).

3. *Guaranteeing robust stability*

In addition to nominal performance, the decentralized controller has to guarantee closed-loop stability over the whole operating range of the plant specified by the chosen uncertainty description (robust stability). Robust stability is examined by means of the  $M-\Delta$  stability condition (47) or the  $M_{af}-Q$  stability condition (59) in case of the affine type additive uncertainty (55).

*Corollary 3.2 (Robust stability conditions under DC)*

The closed-loop in Fig. 3 comprising the uncertain system given as a set of transfer function matrices and described by any type of unstructured uncertainty (41) - (46) or (55) with nominal model fulfilling (60), and the decentralized controller (62) is stable over the pertinent uncertainty region if any of the following conditions hold

1. for any (41)-(46), conditions of *Corollary 3.1* and (47) are simultaneously satisfied where  $M(s) = \ell_k M_k(s)$ ,  $k = a, i, o, ia, ii, io$  and  $M_k$  given by (48)-(53) respectively.
2. for (55), conditions of *Corollary 3.1* and (59) are simultaneously satisfied.

Based on *Corollary 3.2*, two approaches to the robust decentralized control design have been developed: the two-stage and the direct approaches.

1. *The two stage robust decentralized controller design approach based on the  $M-\Delta$  structure stability conditions* (Kozáková & Veselý, 2008;, Kozáková & Veselý, 2009; Kozáková et al. 2009a).

In the first stage, the decentralized controller for the nominal system is designed using ESM, afterwards, fulfilment of the  $M-\Delta$  or  $M_{af}-Q$  stability conditions (47) or (59), respectively is examined; if satisfied, the design procedure stops, otherwise the second stage follows: either controller parameters are additionally modified to satisfy robust stability conditions in the tightest possible way (Kozáková et al. 2009a), or the redesign is carried out with modified performance requirements (Kozáková & Veselý, 2009).

## 2. Direct decentralized controller design for robust stability and nominal performance

By direct integration of the robust stability condition (47) or (59) in the ESM, local controllers of equivalent subsystems are designed with regard to robust stability. Performance specification for the full system in terms of the maximum peak of the complementary sensitivity  $M_T$  corresponding to maximum overshoot in individual equivalent subsystems is translated into lower bounds for their phase margins according to (78) (Skogestad & Postlethwaite, 2005)

$$PM \geq 2 \arcsin\left(\frac{1}{2M_T}\right) \geq \frac{1}{M_T} [\text{rad}] \quad (78)$$

where PM is the phase margin,  $M_T$  is the maximum peak of the complementary sensitivity

$$T(s) = G(s)R(s)[I + G(s)R(s)]^{-1} \quad (79)$$

As for MIMO systems

$$M_T = \sigma_{\max}(T) \quad (80)$$

the upper bound for  $M_T$  can be obtained using the singular value properties in manipulations of the  $M-\Delta$  condition (47) considering (48)-(53), or the  $M_{af}-Q$  condition (58) considering (57) and (59). The following upper bounds  $\sigma_{\max}[T_0(j\omega)]$  for the nominal complementary sensitivity  $T_0(s) = G_0(s)R(s)[I + G_0(s)R(s)]^{-1}$  have been derived:

$$\sigma_{\max}[T_0(j\omega)] < \frac{\sigma_{\min}[G_0(j\omega)]}{|\ell_a(\omega)|} = L_A(\omega) \quad \forall \omega \text{ additive uncertainty} \quad (81)$$

$$\sigma_{\max}[T_0(j\omega)] < \frac{1}{|\ell_k(\omega)|} = L_K(\omega), \quad k = i, o, \quad \forall \omega \text{ multiplicative input/output uncertainty} \quad (82)$$

$$\sigma_{\max}[T_0(j\omega)] < \frac{1}{q_0 \sqrt{p}} \frac{\sigma_{\min}[G_0(j\omega)]}{\sigma_{\max}[G_u(j\omega)]} = L_{AF}(\omega) \quad \forall \omega \text{ additive affine-type uncertainty} \quad (83)$$

Using (80) and (78) the upper bounds for the complementary sensitivity of the nominal system (81)-(83) can be directly implemented in the ESM due to the fact that performance achieved in equivalent subsystems is simultaneously guaranteed for the full system. The main benefit of this approach is the possibility to specify maximum overshoot in the full system guaranteeing robust stability in terms of  $\sigma_{\max}(T_0)$ , translate it into minimum phase margin of equivalent subsystems and design local controllers independently for individual single input - single output equivalent subsystems.

The design procedure is illustrated in the next subsection.

### 3.4 Example

Consider a laboratory plant consisting of two interconnected DC motors, where each armature voltage ( $U_1, U_2$ ) affects rotor speeds of both motors ( $\omega_1, \omega_2$ ). The plant was identified in three operating points, and is given as a set  $\Pi = \{G_1(s), G_2(s), G_3(s)\}$  where

$$G_1(s) = \begin{bmatrix} \frac{-0.402s + 2.690}{s^2 + 2.870s + 1.840} & \frac{0.006s - 1.680}{s^2 + 11.570s + 3.780} \\ \frac{0.003s - 0.720}{s^2 + 9.850s + 1.764} & \frac{-0.170s + 1.630}{s^2 + 1.545s + 0.985} \end{bmatrix}$$

$$G_2(s) = \begin{bmatrix} \frac{-0.342s + 2.290}{s^2 + 2.070s + 1.840} & \frac{0.005s - 1.510}{s^2 + 10.570s + 3.780} \\ \frac{0.003s - 0.580}{s^2 + 8.850s + 1.764} & \frac{-0.160s + 1.530}{s^2 + 1.045s + 0.985} \end{bmatrix}$$

$$G_3(s) = \begin{bmatrix} \frac{-0.423s + 2.830}{s^2 + 4.870s + 1.840} & \frac{0.006s - 1.930}{s^2 + 13.570s + 3.780} \\ \frac{0.004s - 0.790}{s^2 + 10.850s + 1.764} & \frac{-0.200s + 1.950}{s^2 + 1.945s + 0.985} \end{bmatrix}$$

In calculating the affine nominal model  $G_0(s)$ , all possible allocations of  $G_1(s)$ ,  $G_2(s)$ ,  $G_3(s)$  into the  $2^2 = 4$  polytope vertices were examined (24 combinations) yielding 24 affine nominal model candidates and related transfer functions matrices  $G_4(s)$  needed to complete the description of the uncertainty region. The selected affine nominal model  $G_0(s)$  is the one guaranteeing the smallest additive uncertainty calculated according to (41):

$$G_0(s) = \begin{bmatrix} \frac{-0.413s + 2.759}{s^2 + 3.870s + 1.840} & \frac{-0.006s - 1.807}{s^2 + 12.570s + 3.780} \\ \frac{0.004s - 0.757}{s^2 + 10.350s + 1.764} & \frac{-0.187s + 1.791}{s^2 + 1.745s + 0.985} \end{bmatrix}$$

The upper bound  $L_{AF}(\omega)$  for  $T_0(s)$  calculated according to (82) is plotted in Fig. 5. Its worst (minimum value)  $M_T = \min_{\omega} L_{AF}(\omega) = 1.556$  corresponds to  $PM \geq 37.48^\circ$  according to (78).

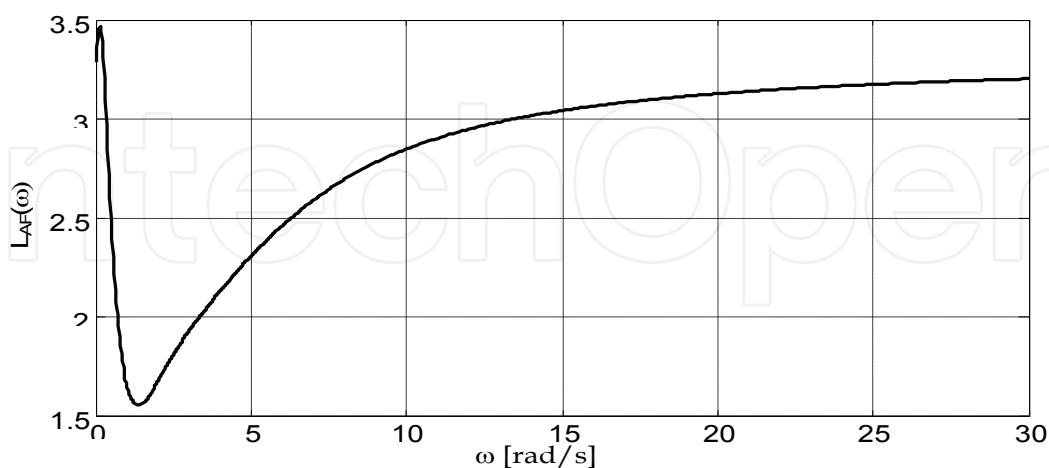

Fig. 5. Plot of  $L_{AF}(\omega)$  calculated according to (82)

The Bode diagram design of local controllers for guaranteed PM was carried out for equivalent subsystems generated according to (74) using characteristic locus  $g_1(s)$  of the matrix of interactions  $G_m(s)$ , i.e.  $G_{i1}^{eq}(s) = G_i(s) + g_2(s)$   $i = 1, 2$ . Bode diagrams of equivalent

subsystems  $G_{11}^{eq}(s), G_{21}^{eq}(s)$  are in Fig. 6. Applying the PI controller design from Bode diagram for required phase margin  $PM = 39^\circ$  has yielded the following local controllers

$$R_1(s) = \frac{3.367 s + 1.27}{s} \quad R_2(s) = \frac{1.803s + 0.491}{s}$$

Bode diagrams of compensated equivalent subsystems in Fig. 8 prove the achieved phase margin. Robust stability was verified using the original  $M_{af}-Q$  condition (59) with  $p=2$  and  $q_0=1$ ; as depicted in Fig. 8, the closed loop under the designed controller is robustly stable.

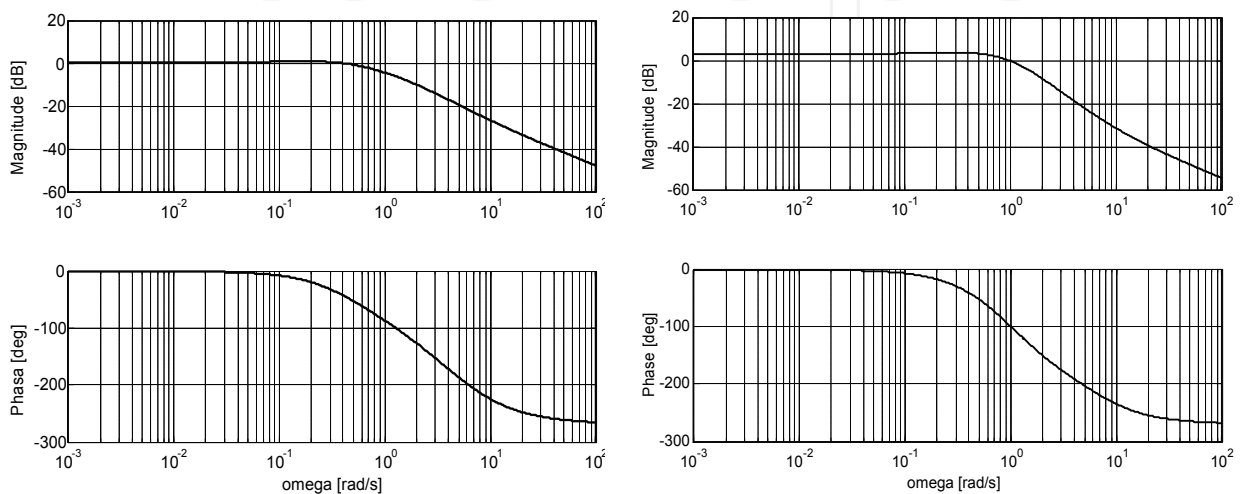

Fig. 6. Bode diagrams of equivalent subsystems  $G_{11}^{eq}(s)$  (left),  $G_{21}^{eq}(s)$  (right)

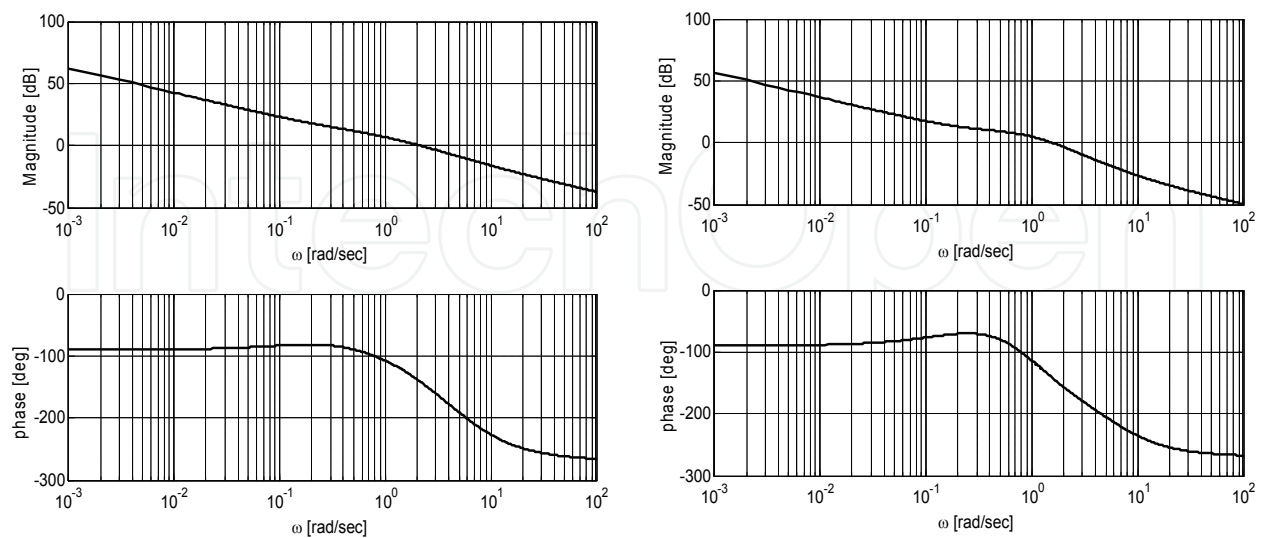

Fig. 7. Bode diagrams of equivalent subsystems  $G_{11}^{eq}(s)$  (left),  $G_{21}^{eq}(s)$  (right) under designed local controllers  $R_1(s), R_2(s)$ , respectively.

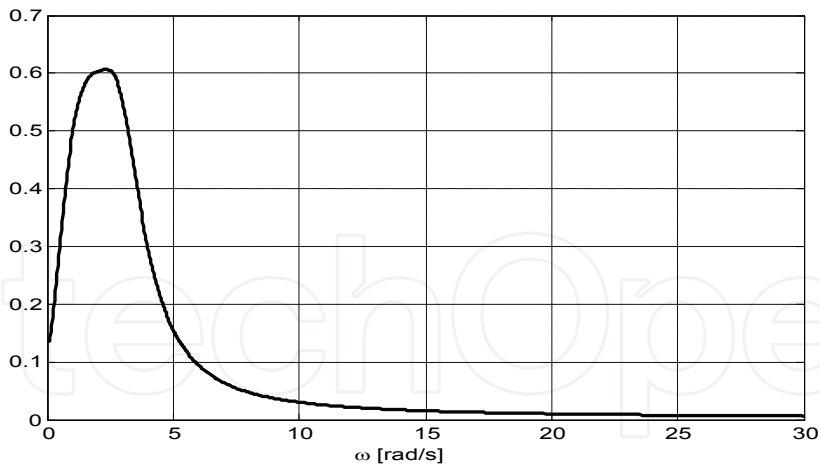

Fig. 8. Verification of robust stability using condition (59) in the form  $\sigma_{\max}(M_{af}) < \frac{1}{\sqrt{2}}$

#### 4. Conclusion

The chapter reviews recent results on robust controller design for linear uncertain systems applicable also for decentralized control design.

In the first part of the chapter the new robust PID controller design method based on LMI is proposed for uncertain linear system. The important feature of this PID design approach is that the derivative term appears in such form that enables to consider the model uncertainties. The guaranteed cost control is proposed with a new quadratic cost function including the derivative term for state vector as a tool to influence the overshoot and response rate.

In the second part of the chapter a novel frequency-domain approach to the decentralized controller design for guaranteed performance is proposed. Its principle consists in including plant interactions in individual subsystems through their characteristic functions, thus yielding a diagonal system of equivalent subsystems. Local controllers of equivalent subsystems independently tuned for specified performance constitute the decentralized controller guaranteeing the same performance for the full system. The proposed approach allows direct integration of robust stability condition in the design of local controllers of equivalent subsystems.

Theoretical results are supported with results obtained by solving some examples.

#### 5. Acknowledgment

This research work has been supported by the Scientific Grant Agency of the Ministry of Education of the Slovak Republic, Grant No. 1/0544/09.

#### 6. References

- Blondel, V. & Tsitsiklis, J.N. (1997). NP-hardness of some linear control design problems. *SIAM J. Control Optim.*, Vol. 35, 2118-2127.
- Boyd, S.; El Ghaoui, L.; Feron, E. & Balakrishnan, V. (1994). *Linear matrix inequalities in system and control theory*, SIAM Studies in Applied Mathematics, Philadelphia.

- Crusius, C.A.R. & Trofino, A. (1999). LMI Conditions for Output Feedback Control Problems. *IEEE Trans. Aut. Control*, Vol. 44, 1053-1057.
- de Oliveira, M.C.; Bernussou, J. & Geromel, J.C. (1999). A new discrete-time robust stability condition. *Systems and Control Letters*, Vol. 37, 261-265.
- de Oliveira, M.C.; Camino, J.F. & Skelton, R.E. (2000). A convexifying algorithm for the design of structured linear controllers, *Proc. 39<sup>nd</sup> IEEE CDC*, pp. 2781-2786, Sydney, Australia, 2000.
- Ming Ge; Min-Sen Chiu & Qing-Guo Wang (2002). Robust PID controller design via LMI approach. *Journal of Process Control*, Vol.12, 3-13.
- Grman, L. ; Rosinová, D. ; Kozáková, A. & Veselý, V. (2005). Robust stability conditions for polytopic systems. *International Journal of Systems Science*, Vol. 36, No. 15, 961-973, ISSN 1464-5319 (electronic) 0020-7721 (paper)
- Gyurkovics, E. & Takacs, T. (2000). Stabilisation of discrete-time interconnected systems under control constraints. *IEE Proceedings - Control Theory and Applications*, Vol. 147, No. 2, 137-144
- Han, J. & Skelton, R.E. (2003). An LMI optimization approach for structured linear controllers, *Proc. 42<sup>nd</sup> IEEE CDC*, 5143-5148, Hawaii, USA, 2003
- Henrion, D.; Arzelier, D. & Peaucelle, D. (2002). Positive polynomial matrices and improved LMI robustness conditions. *15<sup>th</sup> IFAC World Congress*, CD-ROM, Barcelona, Spain, 2002
- Kozáková, A. & Veselý, V. (2007). Robust decentralized controller design for systems with additive affine-type uncertainty. *Int. J. of Innovative Computing, Information and Control (IJICIC)*, Vol. 3, No. 5 (2007), 1109-1120, ISSN 1349-4198.
- Kozáková, A. & Veselý, V. (2008). Robust MIMO PID controller design using additive affine-type uncertainty. *Journal of Electrical Engineering*, Vol. 59, No.5 (2008), 241-247, ISSN 1335 - 3632
- Kozáková, A., Veselý, V. (2009). Design of robust decentralized controllers using the M- $\Delta$  structure robust stability conditions. *Int. Journal of Systems Science*, Vol. 40, No.5 (2009), 497-505, ISSN 1464-5319 (electronic) 0020-7721 (paper).
- Kozáková, A.; Veselý, V. & Osuský, J. (2009a). A new Nyquist-based technique for tuning robust decentralized controllers, *Kybernetika*, Vol. 45, No.1 (2009), 63-83, ISSN 0023-5954.
- Kozáková, A.; Veselý, V. Osuský, J. (2009b). Decentralized Controllers Design for Performance: Equivalent Subsystems Method, *Proceedings of the European Control Conference, ECC'09*, 2295-2300, ISBN 978-963-311-369-1, Budapest, Hungary August 2009, EUCA Budapest.
- Peaucelle, D.; Arzelier, D.; Bachelier, O. & Bernussou, J. (2000). A new robust D-stability condition for real convex polytopic uncertainty. *Systems and Control Letters*, Vol. 40, 21-30
- Rosinová, D.; Veselý, V. & Kučera, V. (2003). A necessary and sufficient condition for static output feedback stabilizability of linear discrete-time systems. *Kybernetika*, Vol. 39, 447-459
- Rosinová, D. & Veselý, V. (2003). Robust output feedback design of discrete-time systems - linear matrix inequality methods. *Proceedings 2<sup>th</sup> IFAC Conf. CSD'03* (CD-ROM), Bratislava, Slovakia, 2003



- Skelton, R.E.; Iwasaki, T. & Grigoriadis, K. (1998). *A Unified Algebraic Approach to Linear Control Design*, Taylor and Francis, Ltd, London, UK
- Skogestad, S. & Postlethwaite, I. (2005). *Multivariable feedback control: analysis and design*, John Wiley & Sons Ltd., ISBN -13978-0-470-01167-6 (H/B), The Atrium, Southern Gate. Chichester, West Sussex, UK
- Veselý, V. (2003). Robust output feedback synthesis: LMI Approach, *Proceedings 2<sup>th</sup> IFAC Conference CSD'03* (CD-ROM), Bratislava, Slovakia, 2003
- Zheng Feng; Qing-Guo Wang & Tong Heng Lee (2002). On the design of multivariable PID controllers via LMI approach. *Automatica*, Vol. 38, 517-526

IntechOpen

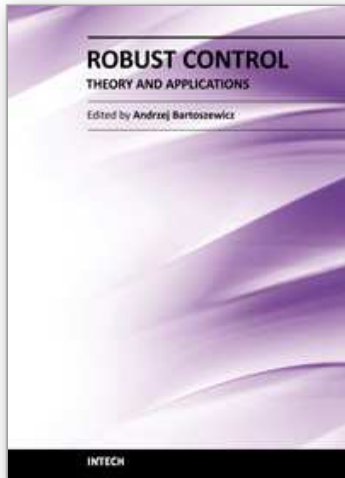

## **Robust Control, Theory and Applications**

Edited by Prof. Andrzej Bartoszewicz

ISBN 978-953-307-229-6

Hard cover, 678 pages

**Publisher** InTech

**Published online** 11, April, 2011

**Published in print edition** April, 2011

The main objective of this monograph is to present a broad range of well worked out, recent theoretical and application studies in the field of robust control system analysis and design. The contributions presented here include but are not limited to robust PID, H-infinity, sliding mode, fault tolerant, fuzzy and QFT based control systems. They advance the current progress in the field, and motivate and encourage new ideas and solutions in the robust control area.

### **How to reference**

In order to correctly reference this scholarly work, feel free to copy and paste the following:

Vojtech Veselý, Danica Rosinová and Alena Kozáková (2011). Robust Controller Design: New Approaches in the Time and the Frequency Domains, Robust Control, Theory and Applications, Prof. Andrzej Bartoszewicz (Ed.), ISBN: 978-953-307-229-6, InTech, Available from: <http://www.intechopen.com/books/robust-control-theory-and-applications/robust-controller-design-new-approaches-in-the-time-and-the-frequency-domains>

**INTECH**  
open science | open minds

### **InTech Europe**

University Campus STeP Ri  
Slavka Krautzeka 83/A  
51000 Rijeka, Croatia  
Phone: +385 (51) 770 447  
Fax: +385 (51) 686 166  
[www.intechopen.com](http://www.intechopen.com)

### **InTech China**

Unit 405, Office Block, Hotel Equatorial Shanghai  
No.65, Yan An Road (West), Shanghai, 200040, China  
中国上海市延安西路65号上海国际贵都大饭店办公楼405单元  
Phone: +86-21-62489820  
Fax: +86-21-62489821

© 2011 The Author(s). Licensee IntechOpen. This chapter is distributed under the terms of the [Creative Commons Attribution-NonCommercial-ShareAlike-3.0 License](#), which permits use, distribution and reproduction for non-commercial purposes, provided the original is properly cited and derivative works building on this content are distributed under the same license.

IntechOpen

IntechOpen