

# We are IntechOpen, the world's leading publisher of Open Access books Built by scientists, for scientists

4,400

Open access books available

117,000

International authors and editors

130M

Downloads

Our authors are among the

154

Countries delivered to

TOP 1%

most cited scientists

12.2%

Contributors from top 500 universities



WEB OF SCIENCE™

Selection of our books indexed in the Book Citation Index  
in Web of Science™ Core Collection (BKCI)

Interested in publishing with us?  
Contact [book.department@intechopen.com](mailto:book.department@intechopen.com)

Numbers displayed above are based on latest data collected.  
For more information visit [www.intechopen.com](http://www.intechopen.com)



# The Challenge of the Skin-Electrode Contact in Textile-enabled Electrical Bioimpedance Measurements for Personalized Healthcare Monitoring Applications

Fernando Seoane<sup>1,2</sup>, Juan Carlos Marquez<sup>1,2</sup>, Javier Ferreira<sup>1,3,4</sup>,  
Ruben Buendia<sup>1,5</sup> and Kaj Lindecrantz<sup>6</sup>

<sup>1</sup>*School of Engineering, University of Borås,*

<sup>2</sup>*Department of Signal & Systems, Chalmers University of Technology, Gothenburg,*

<sup>3</sup>*Swedish School of Textiles, University of Borås,*

<sup>4</sup>*Department of Telematics Architectures and Engineering at the Polytechnic University of Madrid,*

<sup>5</sup>*Department of Theory of the Signal and Communication., University of Alcalá, Madrid,*

<sup>6</sup>*School of Technology and Health, Royal Institute of Technology, Huddinge,*

<sup>1,2,3,6</sup>*Sweden*

<sup>4,5</sup>*Spain*

## 1. Introduction

Textile technology has gone through a remarkable development in the field of Smart Textiles and more specifically in the area of conductive fabrics and yarns. Important research efforts have been done worldwide and especially in Europe, where the EU-commission has supported several research projects in the near past *e.g.* BIOTEX IST-2004-016789, CONTEXT IST- 2004-027291 and MyHeart IST-2002-507816. As a result of such worldwide R&D efforts, textile sensors and electrodes are currently available commercially. Nowadays there are even consumer products with textile sensing technology for heart rate monitoring integrated in the apparel *e.g.* Adistar Fusion T-shirt from Adidas or the Numetrex's Cardio shirt.

Since one of the main areas of focus where R&D efforts have been concentrated is Personalized Healthcare Monitoring (PHM) and the fact that most of the efforts developing textile sensors have been focused on developing electrodes for biopotential signals recording, it is natural that the main targeted application has been the acquisition of electrical biopotentials and especially monitoring the ElectroCardioGraphic activity, but also other types of textile sensors have been investigated *e.g.* textile stretching sensor (Mattmann *et al.*, 2008). Nowadays textile-enable stretch sensors are available commercially like the one manufactured by Merlin Systems. While the application of this type of sensor aims at other applications than biopotential recordings, an important area of application of stretch sensors

still is PHM and fitness. This type of sensors can be used for respiration monitoring or plethysmography applications.

## 2. Electrical bioimpedance

Electrical Bioimpedance (EBI) is a well spread and established technology that has been used as a non-invasive monitoring and health assessment technique for more than 50 years. Since the key-sensing element in EBI measurement technology is an electrode, EBI technology is a strong candidate to benefit from the current progress in the development of textile electrodes and conductive yarns.

Currently EBI technology allows non-invasive monitoring of the respiration cycle by measuring impedance changes across the thorax, cardiac cycle dynamics by measuring changes in the impedance caused by circulating blood across main arteries as well as assessment of body composition and body fluid distribution by measuring EBI at several frequencies. All these current uses of EBI measurements open for several potential textile-enabled applications within PHM, like Heart Failure management home-bounded patients aimed by the EU-FP7 MyHeart Project (Habetha, 2006).

Even though EBI technology is a clear beneficiary of textile-based electrode technology and despite the fact that EBI-enabled wearable physiological measurements is not a new concept, NASA already in 1969 implemented it during the Apollo XI mission, the potential provided by textile electrodes is not fully exploited in EBI technology.

In recent years several investigations (Beckmann *et al.*, 2010; Hännikäinen *et al.*, 2007; Marquez *et al.*, 2009; Medrano *et al.*, 2007) focused on the development of EBI-enabled physiological variables measurement systems with textile electrodes have produced very encouraging results suggesting the feasibility to implement EBI textile-enable applications. The only negative issue with the obtained results is that reliable measurements of EBI have been obtained only when wetting the textile electrodes.

## 3. Skin-electrode interface and measurements of EBI

The contact between the skin and the electronic instrumentation in a non-invasive measurement system is achieved by electrodes. The system resulting from connecting the measurement leads, the electrodes and the skin creates an electrical interface that might influence the measurement process. A schematic of the equivalent circuit is depicted in Figure 1.

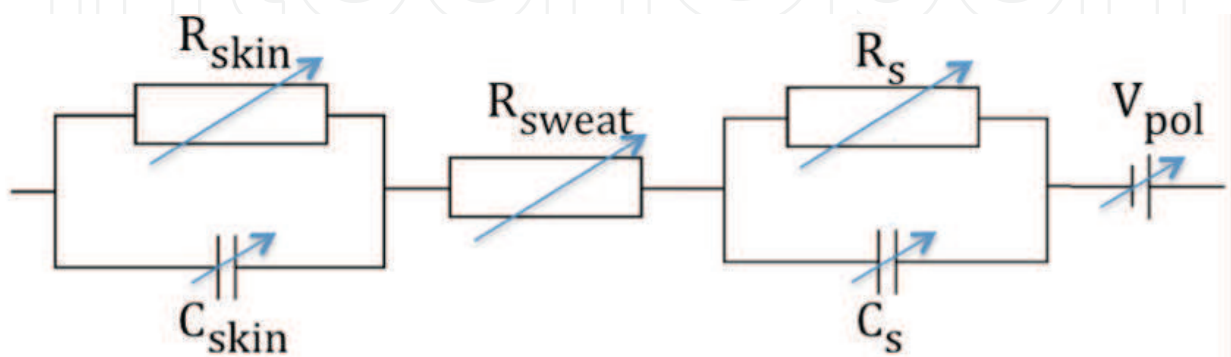

Fig. 1. Electrical Equivalent of the Skin-Electrode Interface

The model of the electrical interface contains a voltage source in series with several impedance elements. The so-called motion artifact in biopotential recordings is represented by changes in the voltage source. In most cases there are several hardware and software solutions available to compensate for it (Witte *et al.*, 1987).

An important difference between biopotential and EBI measurements systems is that the latter, in addition to a voltage measurement, need an injected electrical current through the skin into the body. The need to inject current into the body requires a good electrical contact between the measurement system, the electrode and the skin. It is desirable that the impedance of the electrical interface and the electrode polarization impedance,  $Z_{ep}$ , represented in Figure 1 are small enough to be negligible. If a 2-electrode method is used to measure the EBI,  $Z_{ep}$  will be added to the measurement and the obtained measurement will contain not only the EBI but also the interface impedance. When measuring with a 4-electrode method, it is possible to get an EBI measurement without the contribution of  $Z_{ep}$  or the interface impedance.

The existence of the impedance in series with the measurement load and the stray capacitance creates a frequency dependent current divider, see Figure 2. If the value of the impedance created by the skin-electrode interface present in the current leads is large, the electrical current will avoid flowing through the electrode and the skin, leaking away from the body. Thus the EBI measurement will not be performed at all or in the best case the obtained measurement data will be corrupted with capacitive leakage. See Figure 3. The Figure shows an impedance plot, capacitive reactance vs resistance, with the experimental data plotted with dots, the Cole model estimated from the corrupted data plotted with a fine line and the Cole model estimated from the artifact-free measurement plotted with a coarse line.

#### 4. Textile electrode in EBI measurements

Although as in any other electrode, both the contact area and the material of the electrode are very important factors behind setting the values of the elements constituting the skin-electrode interface. In regular Ag/AgCl electrodes, the electrolytic gel acts “wetting” the interface and facilitating the charge transfer between the electrodes to the skin. The lack of an electrolytic agent in dry textile fabrics increases remarkably the resistance,  $R_s$ , depicted in Figure 1.

The value of  $R_s$  decreases by wetting the electrodes with water, conductive gel or body sweat, the latter is often available during exercise. Another alternative is to manufacture textile electrodes with a special conductive-textile yarn or the appropriate textile structure aiming to maximize the contact surface.

In any case, until a good and stable skin-electrode interface has been created, EBI measurements are unreliable. Spectroscopy applications and time-base analysis applications, where accuracy is a mandatory requirement for implementation, are absolutely compromised. The unpredictability of the impedance of the Skin-electrode interface creates an uncertainty that impedes the deployment of any EBI-based healthcare monitoring at the moment. Fitness and well-being applications might be more robust to a poor skin-contact electrode due to the sweating factor, but at the moment no EBI-textile monitoring system has been made commercially available yet.

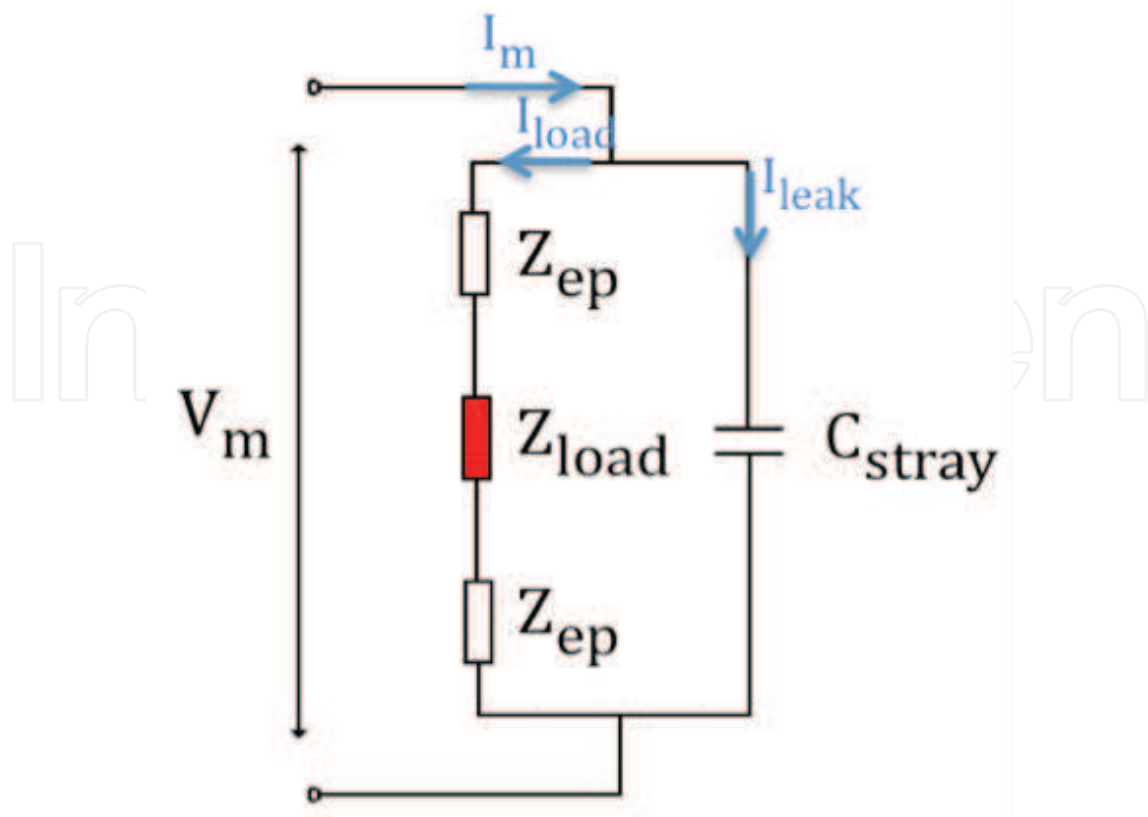

Fig. 2. Electrical equivalent of an EBI measurement setup with a parasitic capacitance in parallel with the impedance load.

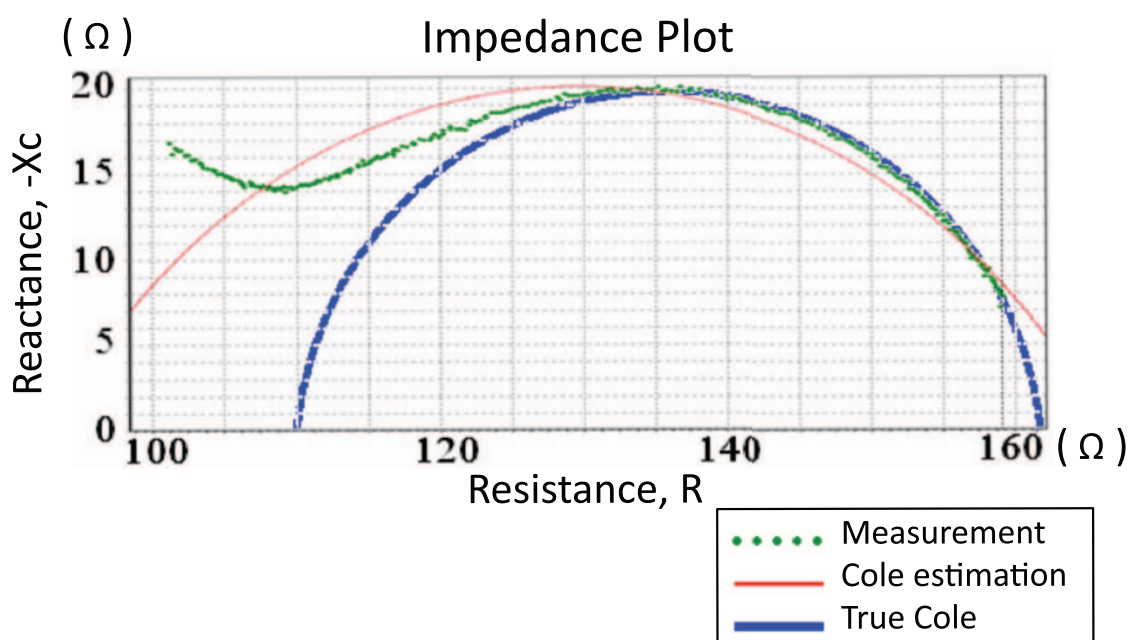

Fig. 3. Typical impedance plot of a measurement showing data deviation caused by a capacitive leakage.

## 5. Conclusion

The natural dryness of the textile material used nowadays as electrodes may not be an impediment for acquiring biopotentials, but it definitely influences in the skin-electrode contact. A dry interface increases the impedance in series with the current injection leads impedance thus preventing the electrical current used to perform the EBI measurement from entering the body. Such impeding electrode-skin interface contributes to generate measurement artifacts producing unreliable EBI data, which consequently delays any deployment of textile-enabled EBI applications. The availability of a 'wet' textile electrode that could facilitate the ionic transfer of charges across the Skin-Electrode interface would definitely facilitate the proliferation of textile-based EBI applications.

Meanwhile such a material is made available the most likely alternative to produce textile electrodes that create a large contact surface with the skin decreasing the value of the skin-electrode as much as possible to facilitate the charge transfer from the measurement system to the measurement load i.e. the body through the skin.

EBI technology can be used to assess on hydration status, monitor the cardiac function, detect fluid accumulation on the limbs and lungs for early edema monitoring, detect ischemic tissue for detection of rejection in organ transplantation and also for monitoring lung function as well as respiration rate.

The successful integration of textile-based sensors in EBI measurements systems would enable the implementation of e-health application for Personal Healthcare Monitoring that would truly cause a shift on how clinical practices are delivery nowadays.

## 6. References

- Beckmann, L., Neuhaus, C., Medrano, G., Jungbecker, N., Walter, M., Gries, T., et al. (2010). Characterization of textile electrodes and conductors using standardized measurement setups. *Physiol Meas*, 31(2), 233-247.
- Habetha, J. (2006). The MyHeart project--fighting cardiovascular diseases by prevention and early diagnosis. *Conf Proc IEEE Eng Med Biol Soc, Suppl*, 6746-6749.
- Hännikäinen, J., Vuorela, T., & Vanhala, J. (2007). Physiological measurements in smart clothing: a case study of total body water estimation with bioimpedance. *Transactions of the Institute of Measurement and Control*(29), 337-354.
- Marquez, J. C., Seoane, F., Valimaki, E., & Lindecrantz, K. (2009). Textile electrodes in electrical bioimpedance measurements - a comparison with conventional Ag/AgCl electrodes. *Conf Proc IEEE Eng Med Biol Soc*, 1, 4816-4819.
- Mattmann, C., Clemens, F., & Tröster, G. (2008). Sensor for Measuring Strain in Textile. *Sensors*, 8(6), 3719-3732.
- Medrano, G., Beckmann, L., Zimmermann, N., Grundmann, T., Gries, T., & Leonhardt, S. (2007). *Bioimpedance Spectroscopy with textile Electrodes for a continuous Monitoring Application*. Paper presented at the 4th International Workshop on Wearable and Implantable Body Sensor Networks (BSN 2007).

Witte, H., Glaser, S., & Rother, M. (1987). New spectral detection and elimination test algorithms of ECG and EOG artefacts in neonatal EEG recordings. *Medical and Biological Engineering and Computing*, 25(2), 127-130.

IntechOpen

IntechOpen



## **Biomedical Engineering, Trends in Materials Science**

Edited by Mr Anthony Laskovski

ISBN 978-953-307-513-6

Hard cover, 564 pages

**Publisher** InTech

**Published online** 08, January, 2011

**Published in print edition** January, 2011

Rapid technological developments in the last century have brought the field of biomedical engineering into a totally new realm. Breakthroughs in materials science, imaging, electronics and, more recently, the information age have improved our understanding of the human body. As a result, the field of biomedical engineering is thriving, with innovations that aim to improve the quality and reduce the cost of medical care. This book is the second in a series of three that will present recent trends in biomedical engineering, with a particular focus on materials science in biomedical engineering, including developments in alloys, nanomaterials and polymer technologies.

### **How to reference**

In order to correctly reference this scholarly work, feel free to copy and paste the following:

Fernando Seoane, Juan Carlos Marquez, Javier Ferreira, Ruben Buendia and Kaj Lindecrantz (2011). The Challenge of the Skin-Electrode Contact in Textile-enabled Electrical Bioimpedance, Measurements for Personalized Healthcare Monitoring Applications, Biomedical Engineering, Trends in Materials Science, Mr Anthony Laskovski (Ed.), ISBN: 978-953-307-513-6, InTech, Available from:  
<http://www.intechopen.com/books/biomedical-engineering-trends-in-materials-science/the-challenge-of-the-skin-electrode-contact-in-textile-enabled-electrical-bioimpedance-measurements->

**INTECH**  
open science | open minds

#### **InTech Europe**

University Campus STeP Ri  
Slavka Krautzeka 83/A  
51000 Rijeka, Croatia  
Phone: +385 (51) 770 447  
Fax: +385 (51) 686 166  
[www.intechopen.com](http://www.intechopen.com)

#### **InTech China**

Unit 405, Office Block, Hotel Equatorial Shanghai  
No.65, Yan An Road (West), Shanghai, 200040, China  
中国上海市延安西路65号上海国际贵都大饭店办公楼405单元  
Phone: +86-21-62489820  
Fax: +86-21-62489821



© 2011 The Author(s). Licensee IntechOpen. This chapter is distributed under the terms of the [Creative Commons Attribution-NonCommercial-ShareAlike-3.0 License](#), which permits use, distribution and reproduction for non-commercial purposes, provided the original is properly cited and derivative works building on this content are distributed under the same license.

IntechOpen

IntechOpen