

# We are IntechOpen, the world's leading publisher of Open Access books Built by scientists, for scientists

5,200

Open access books available

129,000

International authors and editors

150M

Downloads

Our authors are among the

154

Countries delivered to

TOP 1%

most cited scientists

12.2%

Contributors from top 500 universities



WEB OF SCIENCE™

Selection of our books indexed in the Book Citation Index  
in Web of Science™ Core Collection (BKCI)

Interested in publishing with us?  
Contact [book.department@intechopen.com](mailto:book.department@intechopen.com)

Numbers displayed above are based on latest data collected.  
For more information visit [www.intechopen.com](http://www.intechopen.com)



# Diversity Techniques for Robustness and Power Awareness in Wireless Sensor Systems for Railroad Transport Applications

Mathias Grudén, Magnus Jobs and Anders Rydberg  
*Uppsala University  
Sweden*

## 1. Introduction

During the last decades business and industry has been constantly optimizing time in production and transportation. This implies that the margins when doing business are decreasing and when margins are decreasing more information is necessary so that the right decisions can be made on time. This is especially important for the transport sector; in all production there is a need to know when the freight with the components is arriving so that the work can be planned. But as the system grows more sensitive to delays it also implies that delays are getting very expensive. The transport of goods on e.g. trains has therefore to be monitored carefully in order to retrieve information on delays. These delays can be either due to normal circumstances occurring in transports such as scheduling of time tables or due to mechanical faults. Ball bearings used in the trains are vulnerable to damage which also stands for a large fraction of the mechanical faults that contribute to transport delays by causing costly emergent stops.

Recently the Swedish Transport Administration evaluated a system for monitoring the temperature of the ball bearings (Gruden M., et al, 2009). The evaluation was performed within the Uppsala VINN Excellence Center for Wireless Sensor Networks (WISENET). The evaluation was performed during 2008 by mounting wireless temperature sensors on the ball bearings and with a wireless gateway onboard the train. The positions of the sensors can be seen in Fig. 1.1. This system was monitoring the ball bearing of the wheels and air temperature. The measured temperature of the ball bearing was continuously presented on a webpage. By monitoring the temperature it is possible to see trends of heating and predict if the train wagon needs maintenance or not. This type of monitoring system can greatly increase the reliability of the overall system.

One problem noticed with this system onboard the train was the wireless robustness. Due to the metal parts the wireless connection was partially intermittent. One technique which can be used to improve the robustness of a system is the use of multiple antennas at the receiver or transmitter. As the received signal might suffer severe variation from fading phenomena, techniques must be implemented to mitigate these effects. The choice of techniques can generally be classified into two parts, hardware and software. Software solutions to the fading phenomena usually involve various coding techniques to improve the reliability but

this causes slower data rates. Hardware solutions can be found using diversity techniques where two or more antennas are used and then combining the signal using certain schemes can yield significantly increased performance.



Fig 1.1 The position of the wireless sensor.

In this book chapter we will first present the issues of having wireless sensor nodes in train environments. We will also present wave propagation theory to explain why there is a need to introduce diversity techniques to improve the signal quality. In section 2 various well known diversity techniques and implementations will be briefly presented. Due to their intelligence and possibility of decision making, hence high energy consumption and complexity, these types are not suitable for wireless sensor nodes. In section 3 a new diversity combination technique is presented together with some real world measurements that give insight into what kind of performance gain can be expected using the diversity. The new technique presented were developed at Uppsala University, Sweden, as part of the WISENET project on improved wireless communication and wireless sensors in physical and electromagnetic hostile environments. Due to the lower power consumption and simplicity of design this solution is optimized to be use in wireless sensor nodes. First results on this research were presented at EuCAP in 2010 (M. Jobs, et al, 2010). As the need for various wireless devices is increasing exponentially the WISENET group has committed considerable resources to produce new hard- and software technologies to help improve both the robustness and power consumption in wireless devices. Several other, often commercial, forms of wireless devices are gaining ground such as various entertainment systems and sporting gear.

### 1.1 Wave Propagation Theory

In wave propagation there are many different phenomena that will affect the signal. In this section we describe the models used to characterize the radio channel.

### 1.1.1 Path Loss

The well-known Friis transmission formula (Balanis, C.A. 2005) shows a dependence on the frequency, distance between transmitter and receiver, and the antenna gains. The wording “Path Loss” might be slightly misleading as the phenomenon is based around the fact that, assuming an omnidirectional propagation, the energy is spread out over an increasingly larger volume as the distance from the transmitter grows. This causes the received power in a fixed area to decrease exponentially,

$$P_r = \frac{P_t G_t G_r \lambda^2}{(4\pi d)^2} \quad (1)$$

Path loss models are described in the references (Hata, M., 2980) , (EURO-COST 231, 1991), (Kita, N., et al, 2009) and (ITU-R, 2009). The need of expanded models of the Friis transmission equation are motivated by the fact that the basic equation (1) is intended for an ideal environment (with spherical wave propagation and no reflections) which may not be suitable for a real world environments with phenomena such as e.g. losses and various forms of fading. These expanded models are statistical models which determine the attenuation in different environments, mostly in cities and suburban areas. Equation (1) is a special case with losses in an environment without obstacles and multipath propagation. By reformulate equation (1) slightly into

$$P_r = \frac{P_t G_t G_r \lambda^2}{\left(4\pi \frac{d}{d_0}\right)^n} \quad (2)$$

Where  $d_0$  is a distance where reference signal is measured and  $n$  is the path loss exponent. It is then possible to reformulate equation (2) into an equation with levels in dB

$$L_p = P_t - P_r = 10n \log_{10} \left( \frac{d}{d_0} \right) + K \quad [dB], \quad (3)$$

where  $n$  is the path loss exponent,  $K$  is an offset value, and  $d_0$  is a reference distance. In Eq. (1) the path loss exponent is equal to 2 but this is only valid for free-space losses. The earlier and more well known models (Hata, M., 2980), (EURO-COST 231, 1991) have similar variables determined by experiments. By inspecting the formula it is seen that the equation is linear. The variable  $K$  is the offset of the function and is determined by measure the signal level at a reference distance of  $d_0$ . The variable  $n$  is the path loss exponent and is determined by the slope over distance in the measured sequence. This is simply a coefficient of the losses over the distance. Larger coefficient implies greater losses and vice versa. These two variables are determined later in this chapter, and  $d_0$  is preset to 3 m in this case. The variables are determined at two frequencies, 434 MHz and 2450 MHz. The value of  $K$  can not be neglected thus a statistical analyze will be performed which implies that there might be some offset in the linear path loss function.

### 1.1.2 Multipath Propagation and Fading

Multipath propagation is expected in train environments, because of the large amount of metal surfaces. Measurement determines the path losses and the fading environment. This helps when designing the system of wireless sensor nodes. It gives information about where to place the nodes and if there will be problems with the signal quality due to fading. As the electromagnetic waves transmitted will propagate into virtually all directions this will cause some signals to reach the receivers directly while other impinges on various metal surfaces in the environment. These waves will be reflected by the metal surfaces and hit the receiver slightly delayed in time, causing a fast fading superposition of the waves reaching the receiver. This will create a total received signal that might experience severe distortion in amplitude and phase. This fast fading resulting from the multipath propagation can be modeled by the  $m$ -parameter in the Nakagami distribution (A.Goldsmith, 2005)

$$p(r|m, \bar{x}) = \frac{m^m}{\bar{x}^m \Gamma(m)} r^{2m-1} e^{-\frac{m}{\bar{x}} r^2} \quad (4)$$

The lowest possible value of  $m$  is  $m=0.5$ . Rayleigh distribution corresponds to  $m=1$ , which is a severe multipath environment. A large value of  $m$  indicates less fading, which means stronger line of sight. In this paper the measurements are assumed to be Nakagami distributed and  $m$  is determined by fitting the measured data to the theoretical distribution.

## 1.2 Setup

### 1.2.1 Environment

The measurements are carried out at a railway yard in Borlänge, Sweden. The railway yard is located next to a maintenance hall which is a large brick building with some parts made of metal such as ports and small buildings next to the main building. The ground next to the maintenance hall is asphalt and the rail is built on gravel. East of the railway there is a bank which is a few meters high and mostly covered by small trees and bushes, see Fig. 1.2. The setup of wagons in the 434 MHz and 2450 MHz measurements are different because the measurements were performed at different days and the wagons were moved due to ordinary maintenance work at the site. However, the setup in the two cases was made as similar as possible.

#### 1.2.2. 434 MHz Measurements

In the 434 MHz measurements all wagons near the measurement path except one wagon on a track next to the train are open wagons made for transporting timber. These wagons are located from the mark of "Test Site 1" in Fig. 1.2 and south-west bound. The wagon on the track next to the train is a metal tank and is located next to the marking of "Test Site 1".

#### 1.2.3 2450 MHz Measurements

The 2450 MHz measurements are carried out at "Test Site 2" in Fig. 1.2. There are several different types of wagons at this position. The wagon where the transmitting antenna is

positioned is an open wagon made for transporting metal. The wagons next to the transmitting antenna are located northeasterly and are covered wagons, with both soft cover and cover of metal. Fig.1.3 shows a more detailed view of the positions of the transmitting and receiving antennas at this frequency.

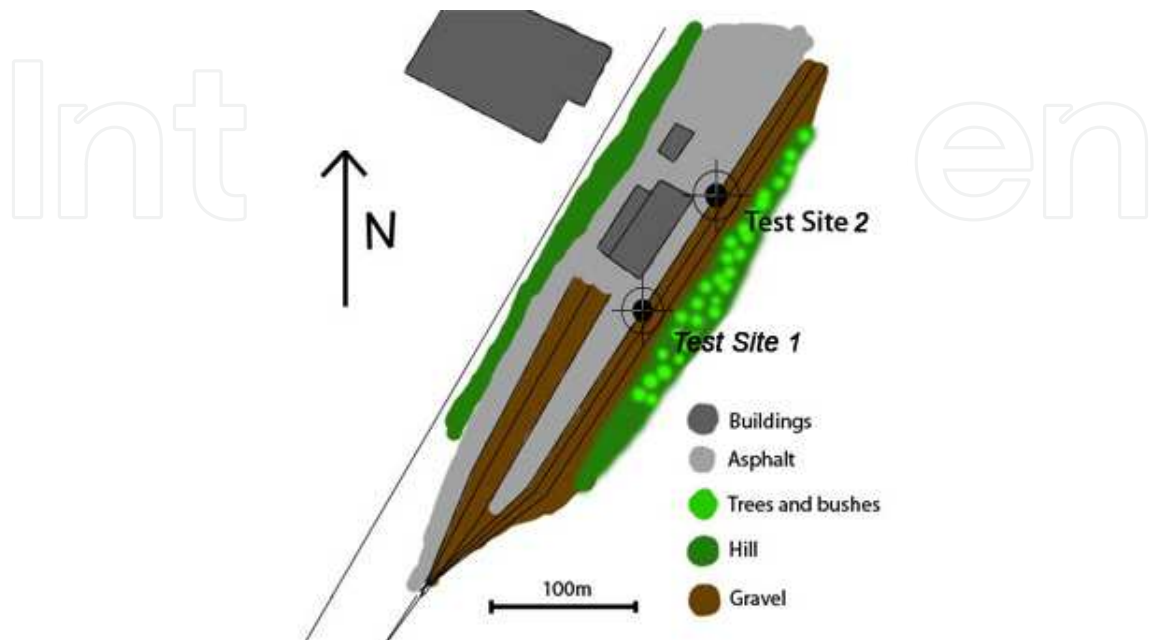

Fig. 1.2 Map of the area where the measurements are carried out.

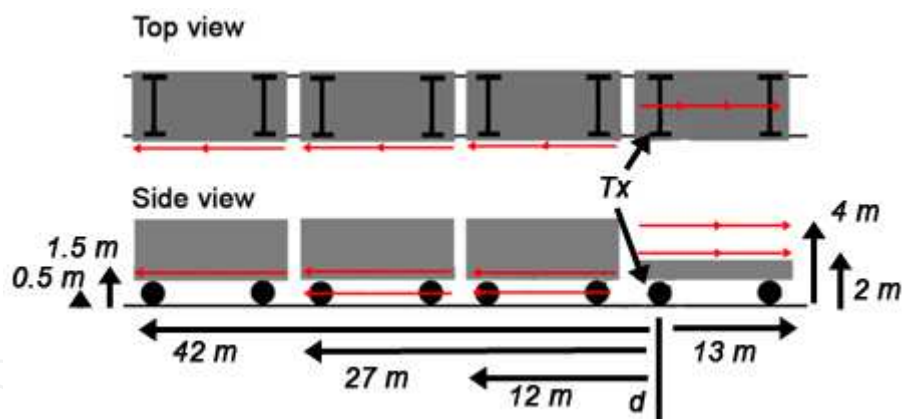

Fig. 1.3. Paths where measurements are performed.

### 1.2.4 Equipment

In the case of 434 MHz, a signal generator connected to an antenna on the transmit side and an antenna connected to a spectrum analyzer on the receive side, are used. In the case of 2450 MHz, the signal generator is connected to a 30 W amplifier to increase signal strength. The power level of the signal generator is set to 0 dBm for both cases, but as mentioned, amplified at 2450 MHz. The increased power level will not affect the results since the path loss results are relative. The amplifier was only used in order to increase the dynamic range in the measurement. The antennas used are matched dipoles. The equipment is portable to enable easy change of antenna locations.

### 1.2.5 Measurement Procedure

In all measurements the transmit antenna is fixed and the receiving antenna is moved along a path while recording the signal level. Each measurement consists of a few seconds of stationary measurements in the beginning. After that, a walk of a certain distance and in the end of the walk the receiving antenna is placed in a static position again for a few seconds, hence it is easy to see where the measurement starts and ends. The total length of a measurement is 20 seconds. The starting distance and distance of movement is recorded. The value of  $d$  is noted at the start and the end. During the movement of the antenna it is assumed that the velocity is constant. Although measurements are recorded as amplitude versus time, in the post-processing the data is converted to amplitude versus distance, thereby making it possible to determine the path loss as a function of distance. A reference measurement is performed at  $d_0$  (3 m from transmitter in this case), and this value is subtracted from all measured samples.

The data acquired by the above procedure is analyzed using a linear regression on the same form as Eq. (2). From this linear regression the values of  $n$  and  $K$  are found. The offset value is determined by subtracting the reference value from the value of the linear regression at  $d_0$ .

### 1.3 Measurement Results

Measurements are performed along different paths and at different locations, cf. Fig. 1.3. Both measurement paths are close to the wagon, one of them along the side of the wagon and one on top of the wagon (if it is an open wagon). The results of all measurements are analyzed and compared depending on location, e.g. all measurements beside the wagon are combined, and so forth. Two typical measurement is seen in Fig. 1.4, one at a frequency of 2450 MHz and one at 434 MHz. It clearly seen in the figure that the fading is more severe at higher frequencies.

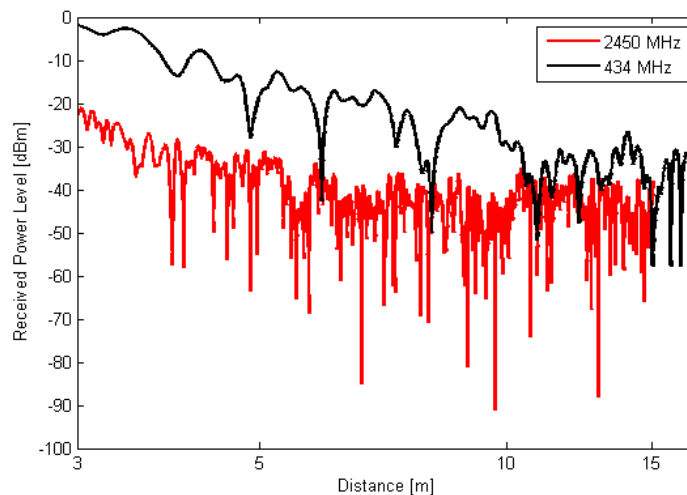

Fig. 1.4. Typical measurement at 434 MHz and 2450 MHz.

The resulting values of  $n$  and  $K$  in the case of measurements beside the wagon are seen in Table 1, and  $m$  is seen in Table 2.

Freq. [MHz]	No. Measurements	$n$		$K$ [dB]	
		Mean	Range	Mean	Range
434	39	3.67	1.56 to 4.72	-6	-15 to 0
2450	26	2.22	1.37 to 3.03	-5	-25 to 5

Table 1. Path loss exponent and offset beside the wagon.

Freq. [MHz]	$m$	
	Mean	Range
434	2.6	1.3 to 7.3
2450	1.3	1.2 to 1.5

Table 2. Fading parameter along the side of the wagon.

Along the second path where measurements are performed on top of an open wagon, the results are slightly different. The results for this path are seen in Table 3 and Table 4.

Freq. [MHz]	$n$		$K$ [dB]	
	Mean	Range	Mean	Range
434	2.27	1.06 to 3.82	-13	-20 to -7
2450	0.32	-0.33 to 1.85	-2	-10 to 5

Table 3. Path loss exponent and offset on top of the wagon.

Freq. [MHz]	$m$	
	Mean	Range
434	2.1	1.4 to 3.5
2450	1.5	1.2 to 2.1

Table 4. Fading parameter on top of the wagon.

The smaller path loss exponent at the higher frequency is due to the metal details on the train wagon. They are at a size of a wave length or larger at 2450 MHz but most of the details are smaller compared to the wave length at 434 MHz. The sizes of the details make them to passive radiators at 2450 MHz but not at 434 MHz. This helps the communication link so it is having lower path exponent loss at a higher frequency, see Fig. 1.4.

#### 1.4 Comparison with Simulations

Simulations are performed at 434 MHz using CST Microwave Studio. A properly simulated and verified model provides a powerful tool fast evaluation of proposed systems and antenna concepts. As such it is important to compare measured and simulated data to create reliable model which should be as well validated as possible. The simulation model is a simplified wagon with two bogies with two wheels on each bogie, as seen in Fig. 1.5. Next to the wagon is another truncated wagon that only contains one bogie. The transmitting antenna is placed near this bogie and is vertically oriented. The average power is monitored



and data is acquired along the same paths as the measurements. An example of the results is shown in Fig. 1.5.

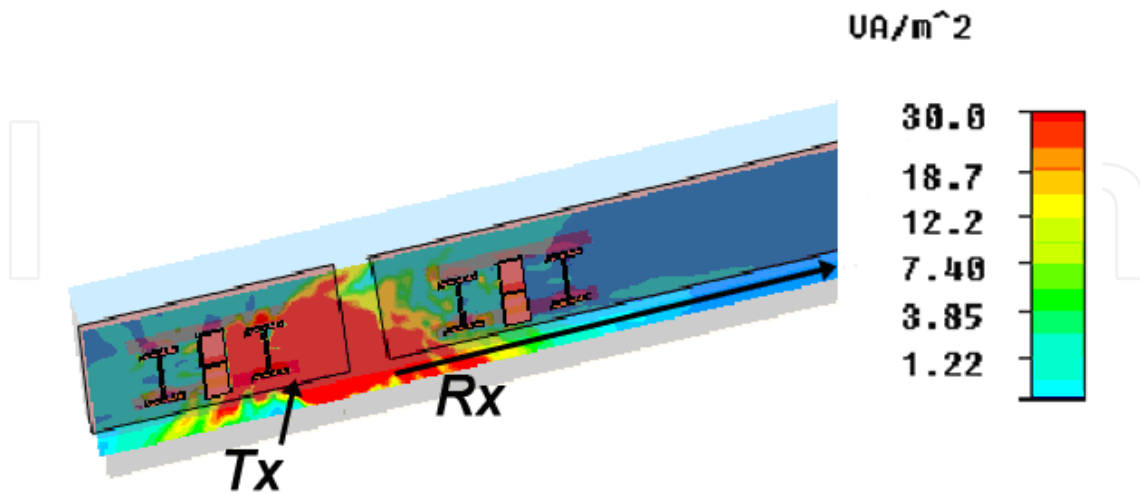

Fig. 1.5. A simulation result showing the field strength. Visualizing plane is approximately at a height of 0.5 m above ground level.

As seen in Fig. 1.6 the simulated level is higher than the measured values, and the simulated values show no fast fading. This is due to the fact that the simulated and presented values are total absolute values of the amplitudes measured on all three polarizations. The simulated path loss exponent is roughly equal to the measured one. One could expect the simulated effects of slow fading, i.e. shadowing or losses in environment to be better correlated to the measured ones. Fast fading on the other hand is highly dependent on the environment, like number and location of reflectors etc., and as such unless a very well defined environment is used for measurements very good correlation will be harder to achieve. The model is as good and detailed as it can be with the current computer technology.

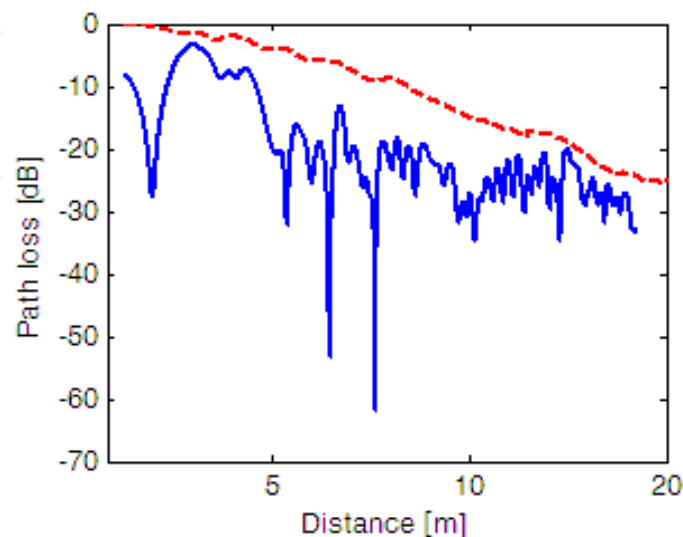

Fig. 1.6. Comparison between simulated (red dashed line) and measurement (blue line) data.

### 1.5 Motivation to Introduce Diversity

The fast fading seen in Fig 1.4 is one of the most important issues to deal with when improving the wireless communication. By using only one antenna transmitted data can be lost due to severe fading dips. Imagine having two antennas with spatial diversity, and one of the antennas is placed in one of the fading dips. The other antenna will most probably be located outside this fading dip and the signal level can be up to 50-70 dB higher for the antenna outside the fading dip. This prevents packet loss and limits the need to retransmit packages, this lowers the overall power consumption.

## 2. Common Diversity Techniques

The general explanation of a diversity system is a wireless system that uses several independent channels to communicate in order to increase the reliability of the system. Choosing to use diversity could be considered making a tradeoff by increasing the overall power-consumption in order to get more reliable communication. A diversity system has to be implemented with two parts. One part consists of a diversity antenna, the second part is the combiner which consists of electronic components and includes an intelligent control system. It also exist diversity by using frequency or time coding. But these will not be analysed in this chapter. There are many different types of solutions for both the design of the antennas and for the combiner. How they work individually are described in section 2.1 and 2.2. It will be clear that these techniques are not always suitable for wireless sensor nodes due to the required power to feed the controlling circuitry. The solution later presented in this chapter is only a solution for the combining technique not the antennas. The new technique is less intelligent than the common ones but more suitable for wireless sensor nodes.

### 2.1 Combining Techniques

One part of the diversity systems has to consist of electronic circuitry. This part has to include some sort of intelligence to enable signal improvement. The general idea about how the combination technique is implemented is seen in figure 2.1. As can be seen that some type of feedback network is used to allow adaptive control of the incoming signals which will increase the overall signal reliability.

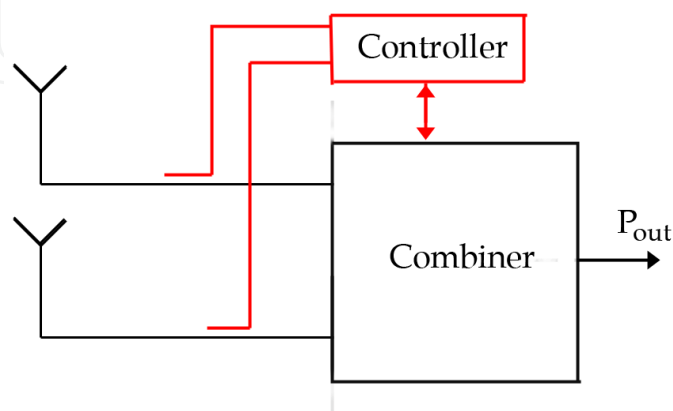

Fig. 2.1. The general idea of combining techniques.

In general the standard form of combining circuits include some network of controllable phase shifters and amplifiers with a combining circuit which will superposition the incoming signals. The difference between the types of combining techniques is mainly dependent on how the controlling algorithms are set-up to handle phase shifting and amplification of incoming signals before they are combined together to create one unique signal. The drawback with these systems is their energy consumption and the complexity.

### 2.1.1 Selection Combining

The selection combining is the most simple combination technique that can be implemented in a circuit. When having two branches the controller is detecting the received signal level in each branch. The decision is made to choose the branch with the highest signal level at the moment. A sketch of the technique is seen in figure 2.2.

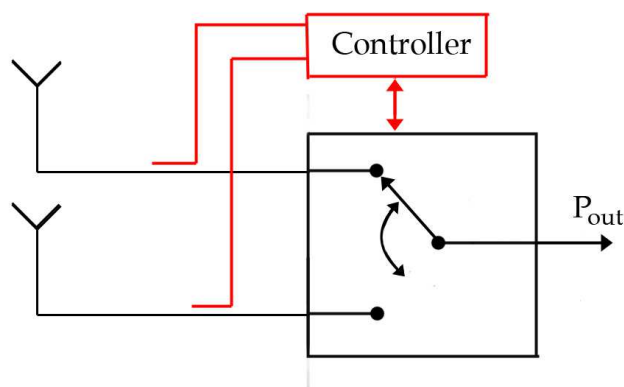

Fig. 2.2 Selection combining.

### 2.1.2 Equal Gain Combining

Equal gain combining is one of the more advanced techniques. This technique is based on one phase shifter per diversity branch and one combiner/summation. The controller circuit is controlling the relative phase shift of the branches and is shifting the phase so when the signals are combined they are in phase and do not have destructive interference.

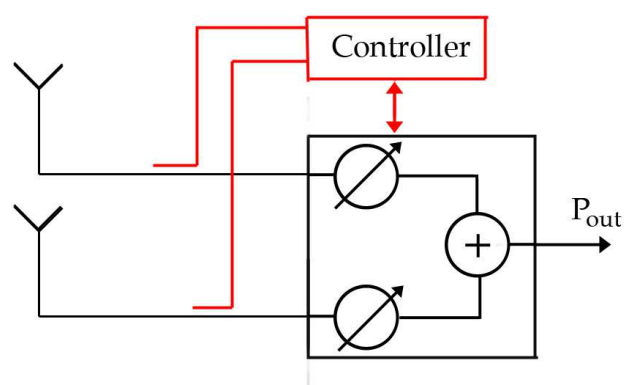

Fig. 2.3. Sketch of equal gain combining.

### 2.1.3 Maximum Ratio Combining

The maximum ratio combining is probably the most advanced sort of diversity circuits. The controlling circuit is as usual determining the amplitude and phase of the branches. In this stage the circuit is controlling both an amplifier and a phase shifter on each branch. The signals are adaptively amplified and phase shifted before they are constructively combined.

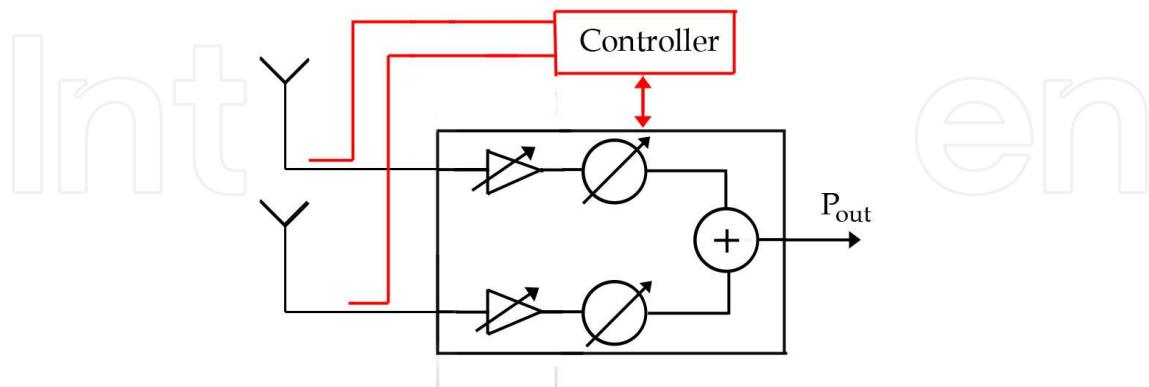

Fig. 2.4 Sketch of maximum ratio combining.

## 2.2 Antenna Diversity Techniques

As mentioned previously the diversity receiver/transmitter consists of two different parts, the combination techniques and the antenna design. To achieve a good reception and a fully working circuit there is a need for a good antenna design. When considering an antenna design some parameters are more important when the antenna shall be used for a diversity implementation. In this section three of the key parameters for a good diversity antenna are listed, correlation, polarization and spatial diversity. The correlation is probably the most important parameter of these three, it describes the performance of the antennas by comparing how well a signal received at one the antennas couples to the other. Ideally each antenna should be considered a independent channel in which we would have no correlation between them.

### 2.2.1 Correlation

The level of correlation between antenna elements is the most important parameter when designing a diversity system. This part is, however, not independent of the other two design parameters polarization and spatial properties for the antenna system.

When talking about correlation we simplify the discussion to a system with only two branches since the available space for on the sensor node is very limited. Limited area to use for antennas also implies that the spacing between the antenna elements can not be adjusted which would help minimise the correlation. In the case of two antennas that are correlated the signal level at the output port of one antenna can be determined based on the signal on the other antenna. For the uncorrelated case this is not possible. For two antenna elements on a sensor node falls in between the two cases due to the close distance between the elements. However even though there exists a strong correlation between the antenna elements due to the close spacing in-between the improvement in a multipath environment it is shown that e.g. in the case of polarisation diversity the wireless link budget can be improved by several tens of dB by changing the polarisation in case of fading dip (Buke,A., et al, 1999). Even small improvements in the link budget can be important in creating a

robust communication in the sensor network. The correlations between the output signals from two antennas are described in (Simon, M.K., 2002) the time domain by the eq. (5).

$$\rho = \frac{E[(X_1(t) - \mu_x)(X_2(t) - \mu_y)]}{\sigma_{X_1} \sigma_{X_2}} \quad (5)$$

The correlation is calculated by using statistics of measured sequences.

### 2.2.2 Polarization Diversity

When designing the antennas to be used for diversity there are some ways to decrease the correlation. One of the simplest ways is to design the antennas with polarization diversity. If we use two antennas, this means that the two antennas have perpendicular polarization. For the simplest case, with two dipoles, this means that the antennas shall be perpendicular as well, as seen in Figure 2.5.

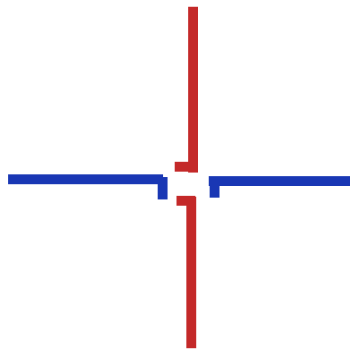

Fig. 2.5. An example of polarization diversity with two dipoles (red and blue).

### 2.2.3 Spatial Diversity

Spatial diversity is similar to polarization diversity but there is no need to have the antennas in the same position. In this case the antennas have exactly the same radiation pattern, but the distance,  $d$ , between the antennas will cause the incoming EM-waves to have different amplitude levels at the same moment in time. This can be seen in figure 2.6.

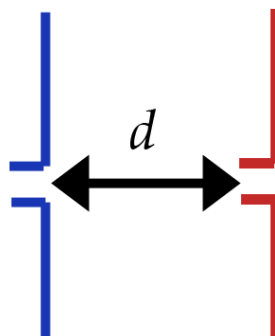

Fig. 2.6. Example of spatial diversity for two dipole antennas.

If the distance  $d$  is zero the output signal from the antennas are totally correlated. In this case they are totally correlated and no diversity can be achieved. The correlation decreases with distance and is usually low enough at a distance of  $d=\lambda/2$ . Depending of the design of the antenna both larger and smaller distances between the antennas can fulfil the demanded correlation (Valenzuela-Valdes, J.F., et al, 2009).

### 3. Opportunistic Combining

In previous sections it was determined that diversity had to be designed with some sort of adaptivity to the present environment. It also implies that the diversity system has to be designed along with the receiver itself. The disadvantage of the more well-known types of diversity presented in the previous section is that it demands intelligence to make decisions about how to combine signal or choose the antenna branch with the best signal level. To have an intelligent circuit it demands a micro controller, which drastically increases the energy consumption. Recently a technique has been presented (Jobs, M., et al, 2010) that shows an alternative solution to the standard feedback-based solutions. This new type of combination does not need any sort of intelligence and can be realized with ordinary lumped components, see fig. 3.1. By its simplicity it does not have to be designed to work for one single radio system it can also be added on already existing radio circuits.

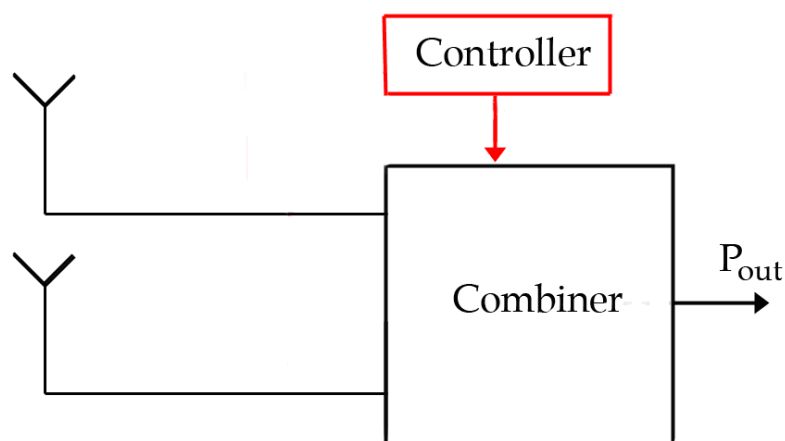

Fig. 3.1 The idea of opportunistic combining.

#### 3.1 Basic Concept

To be able to strip down the system and save energy by not having to analyze data and take any decisions the system needs to be opportunistic. This means that the system behaves in the sense that it tries to take advantage of existing signals to improve the signal quality but do not use adaptive feedback to control the receiving circuit. By using a combiner circuit that cycles through a number of predetermined configurations it is possible to use an averaging or peak detector to create a stronger received signal when considering the time average.

In this case the electronics have a limited number of combinations it will cycle through. As seen in the previous types of combination techniques it is possible to use selection or phase

shifting of the signal before adding them together to achieve a good output signal. The proposed technique here is to use a 2 or more uncorrelated received signals from antennas and during each received (transmitted) symbol change the phase shift between the receiver (transmitter) branches so that the total symbol will be a combination of phase shifted signals, as described below:

$$S_{received} = \frac{1}{NrCombinations} \sum_{k=0}^{NrCombinations} \left( \sum_{l=0}^{NrAntennas} A_l e^{jw\phi_{l,k}} \right) \quad (6)$$

The equation above describes the received signal in an averaging detector connected to an opportunistic diversity switch. During each transmitted symbol all combination of phases are used. This unique sum of signals is created once or more during each received symbol. This could be visualized as sweeping the antenna pattern during each symbol and as such creating angular diversity in the received signal. In a multiscattering environment each direction will receive a unique sum of planar waves which are superimposed and creates a fading signal. By using a directive antenna which changes the position of its main lobe different sums of planar waves will be received and each sum will have a unique signal strength.

In the implementation of such a switch, presented below, 2 antennas were used each with a binary phase shifter. This created a total of 4 different signals during each symbol received. However, using even a limited number of phase shifts significant increase in receive strength can be obtained as long as each phase-shift combination is chosen such as the change in antenna pattern is as large as possible. Depending on the type of antenna array used the phase-shifting circuit is designed for optimal performance of the opportunistic combining.

### 3.2 Electronics & Performance

The overall goal using an opportunistic combiner is to keep both power consumption and component cost to a minimum. Seen from a pure performance perspective the opportunistic combiner will never be as efficient as, for example, a selection combiner or maximum gain combiner. One of the advantages of the opportunistic combiner, as mentioned previously, is that it keeps power consumption to a minimum. When coupling this to the fact that it can be built using only a small number of components it is possible to implement the advantages of diversity in applications that are both cost sensitive and power constrained. However, the diversity switching system needs to be carefully designed to minimize the insertion loss of the system and improve efficiency.

The phase shifter itself can be implemented using a number of techniques, as the only goal of the phase shifter is to be able to switch between several predefined phase shifts while keeping power consumption low. The two major groups of switching techniques used is normally either PIN-diode (diode consisting of three layers which is P-doped, intrinsic and N-doped creating a current-controlled RF-resistor) based switches or transistor based. Transistor based switches is a good choice due to the fact that each phase shift needs to exist during the time between each shift and a transistor based solutions can provide just that. PIN-diode based switches are very simple to implement but suffer from the fact that they need a continuous current to function. Due to the fact that the resistance is linear as a

function of current the performance is directly linked to power consumption. As such, if a low loss application is desired the power requirements for such a solution will increase.

In the hardware used for the opportunistic combiner proof-of-concept PIN-diodes were used only due to the fact that power consumption was a secondary in this particular implementation. In the circuit seen in Fig. 3.2 two binary phase shifters consisting of two PIN-diodes each coupled to a pi-network provided a phase shift of 90 degrees. This allowed for a total phase shift between the receiving branches of 0°, 90°, 180° and 270°.

In order to complete the system some form of switching circuit needs to be implemented that switches between the different phase shifts. As the system does not need to implement any form of intelligent behaviour, any form of simple multivibrator circuit can be used to keep the phase shifters in continuous rotation. However, care might have to be taken to assure that the frequency of the clock-circuit can be tuned in such a way that it can support all the various baud rates intended in the target application. If the application is such that only a single baud rate is supported this restriction can be alleviated and reduce the complexity of the system even further. The required clock rate from the multivibrator can be described as follows:

$$f_{upper} \geq f_{switch} \geq f_{symbol} \quad (7)$$

$$f_{switch} = n \cdot C \cdot f_{symbol}, \quad \text{when } n = 1, 2, 3, \dots \quad (8)$$

The variable  $C$  is the number of relative phases, in this case  $C=4$ , and  $n$  is the number of repetitions of the phases during each symbol. The highest frequency of switching is  $f_{upper}$ . If this frequency is too high the system will start deteriorating due to spectrum broadening. However, using only the lower limit of one rotation per received signal should still give good results, also using only one rotation the interference due to switching noise can be minimized. In Fig. 3.3 the received signal during switching is illustrated. In the figure four different phase shifts are cycled through and it can be seen how one of the received signals enters a fading null while the other four phase shift combinations are keeping a relatively constant level.

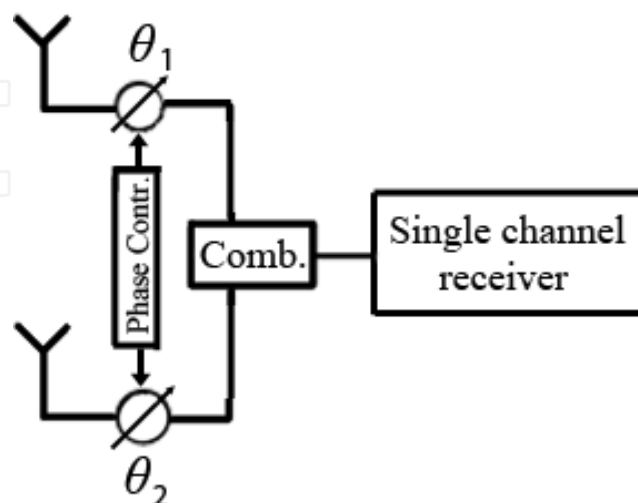

Fig 3.2. Block diagram of the opportunistic diversity combiner, which is connected to the receiver.



Opportunistic combiner should provide a simple mean to implement diversity in a system but it does have some important restrictions. One of the major restrictions is that phase-noise is injected into the system. This causes phase-based modulation techniques to experience severe distortion in the system. As a result it is predicted that phase-modulated systems such as Quadrature Phase Shift Keying (QPSK) and Quadrature Amplitude Modulation (QAM) will be unable to implement opportunistic diversity switch in its simplistic form. Any form of modulation where phase information is discarded such as Amplitude Shift Keying(ASK) and Frequency Shift Keying (FSK) will, however, be good candidates for implementation of opportunistic combining.

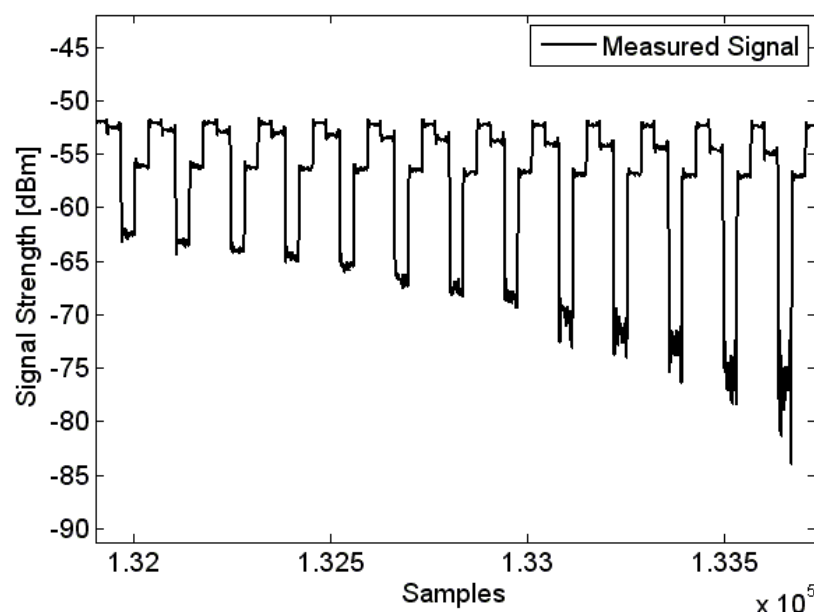

Fig. 3.3. Received signal from diversity combiner in office environment. One of the phase combinations is seen entering a fading dip.

The ultimate diversity gain obtained from a system implementing a opportunistic diversity switch is dependant on the type of detector used in the transceiver system. An opportunistic combiner relies on the detector in the receiver architecture to perform either an averaging or peak detection on the incoming signal. This means that care should be taken when evaluating the performance of a system. If the receiver uses a peak detector the theoretical optimum performance should be obtained as it means that the maximum level of the phase shifter output will be captured and used. If, however, an averaging detector is used the system will not be optimum but should still provide very good protection against deep fading nulls. It is expected that most system considered for implementation of a opportunistic diversity combiner will have some form of averaging combiner.

In Fig. 3.4 seen below all the previously defined parameters has been implemented in a "Proof Of Concept" system. This system was used to evaluate the performance of a opportunistic combiner in a amplitude modulated (ASK) system. The purpose of this rather crude prototype system was to measure the diversity gain obtained in a system based on opportunistic combining. The switching circuit in this case was a small microcontroller rather than a multivibrator in order to give a fully customizable switching signal for the

phase shifters for evaluation purposes. The power consumption of the PIN-diodes was controlled externally and during testing it was set to a rather high 10 mA per switch. This is obviously much too high to be considered for a wireless application but with modern Integrated Circuit (IC) RF-switches, pushing power consumption down in the micro-watt ranges, a low power implementation of the system described is not unrealistic.

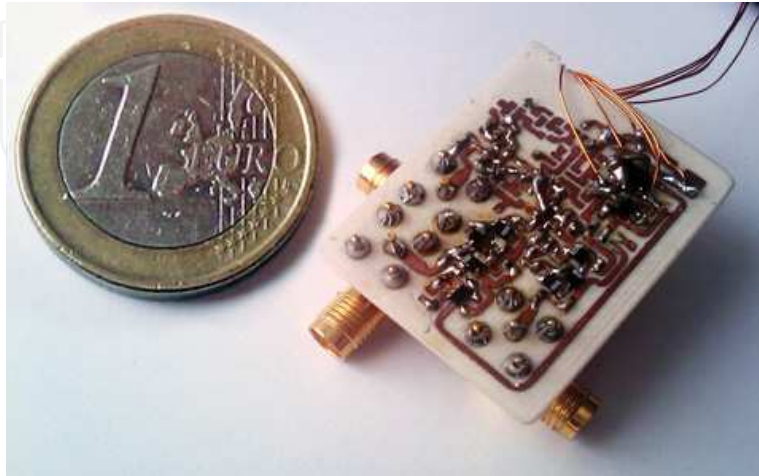

Fig. 3.4. Photo of the add-on diversity combiner, with SMA connectors for the two diversity antennas and the receiver.

A prototype of the opportunistic combiner was developed and tested in both a fully reflective environment (Reverberation Chamber) and a standard office-type environment. This allowed for evaluation both during theoretically optimum circumstances as well as a “real life” application. Using a pair of uncorrelated diversity antennas based on spatial diversity the signal strength seen in Fig. 3.5 and Fig. 3.6 were obtained. It can be seen that the combiner increases the average signal strength and mitigates the deep fading nulls which will otherwise cause packet loss or extend the transmitting range. This would allow the target application to either reduce the number of retransmissions necessary or decrease the amount of error-correcting code previously needed to obtain an adequate transmission. The reduced requirements on retransmissions and error-correcting coding can now be used to either provide a more robust communication or allow for an increase in data rate. In each case the implementation of an opportunistic combiner in the system can clearly be seen to have a significant impact on the robustness and overall power consumption of the system.

In general the environment in which a wireless system will be implemented and the requirement of robustness will determine if a diversity based solution is preferred. Rural environments will in general only suffer from slow fading and propagation losses and in such a system diversity switching might not be a good solution as it will require some increase in power consumption and overall cost of the system. However, if the system is to be implemented in an urban and multiscattering environment then the extra cost of adding a diversity switch to the wireless system could prove to both increase the lifespan through energy conservation and reliability of the system by not having to retransmit data.

The results from the evaluation of the diversity combiner prototype showed a significant increase in received signal strength during fading nulls. Using 90 percent signal reliability the diversity gain of such a system was measured in an ideal environment to be 5.5 dB for an averaging detector and 10.3 dB for a peak detector. In the office environment the

combiner gave a 1 dB gain using an averaging detector and 5.4 dB using a peak detector. This means the system will experience a significant increase in reliability.

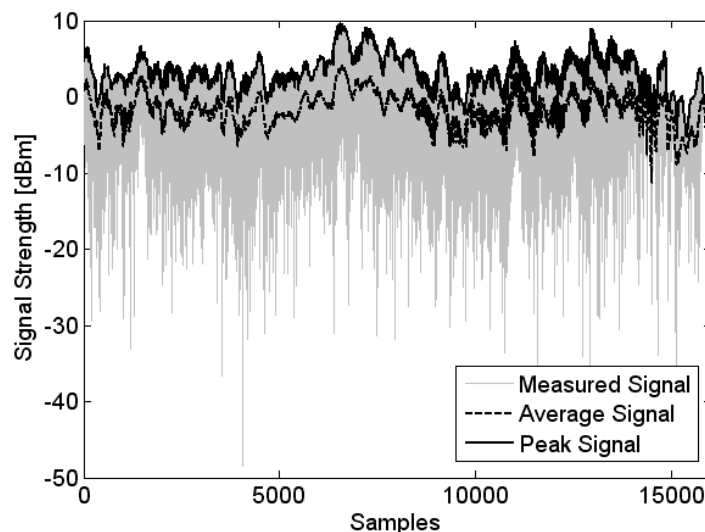

Fig. 3.5. Measured signal in reverberation chamber received from diversity combiner with peak and average signals marked.

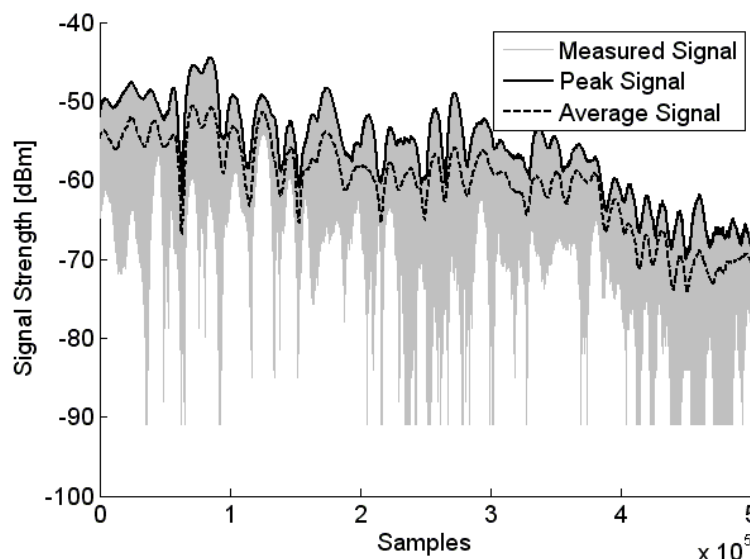

Fig. 3.6. Measured signal in office environment received from diversity combiner with peak and average signals marked.

### 3.3 Modulation Types

As mentioned in section 3.2 the proposed switching technique is primarily intended to be implemented in an ASK or FSK based sensor system. Both of these modulation types has the information stored in either the amplitude (ASK) or the frequency (FSK) and as such is unaffected by changes in phase of the received and/or transmitted signal. However, as the phase-shifters only shifts through a number of known positions it is should be possible to

add a compensation circuit in order to remedy this to some extent. No research has at the time of writing this chapter been presented on this.

#### **4. Implementing diversity in design**

The choice to implement some form of diversity should be considered at an early stage of the design of the sensor node. Even though certain diversity techniques such as the opportunistic combiner presented previously is possible to add as an external component this should be avoided if possible. If a wireless node is designed to be low cost, low power and robust this requires that the component count is kept at a minimum as well as board space. Also, if the node houses some form of intelligent processing, i.e. a microcontroller, the need for a multivibrator for the diversity switch can be omitted in favour of direct control by the microprocessor. This further reduces the amount of components.

As mentioned previously in section 3.2 if the design is realized using lumped components instead of an Application Specific Integrated Circuit (ASIC), the phase shifters should be implemented using transistors or an dedicated IC rather than diodes. As most commercial applications are manufactured using lumped components and ICs this would be the most common situation.

#### **5. Conclusion**

As we have seen in this chapter there are several important aspects to consider when looking at the reliability and signal robustness of a wireless sensor system in a multiscattering environment. Phenomenon such as propagation losses and fading needs to be modelled correctly in order to give an acceptable representation of the proposed environment. Once a good representation for this has been found various techniques can be implemented that increases the reliability of the system.

By implementing diversity in the system, i.e. using more than one transmitting or receiving antenna, the signal reliability can be increased significantly. However, this comes at the cost of increased complexity and power consumption of system which should be reduced particularly in a sensor node and systems. The use of an opportunistic diversity combiner has been proposed as a way to increase the reliability in system using simpler modulation schemes and fits well where a sensor node is using ASK or FSK based modulation. Such a technology can implement diversity in the system while keeping the amount of additional hardware and power consumption at a minimal level.

Finally some measurements using a prototype system has been presented in which one can clearly see the improved performance when using a opportunistic combiner as opposed to no diversity combining. This combiner was implemented using a minimal amount of external components and as such similar implementations should be considered useful for various embedded wireless devices.

#### **6. Acknowledgements**

The authors would like to thank Dr. Paul Hallbjörner at SP Technical Research Institute of Sweden, for all his help and encouragement. The authors would also like to thank Dr. Erik

Björnemo at Uppsala University, department of Signals and Systems, for all good discussions and constructive criticism.

## 7. References

- Allnatt, J.W.; Jones, E.D.J.; Law, H.B. (1957); "Frequency diversity in the reception of selectively fading binary frequency-modulated signals", Proceedings of the IEE - Part B: Radio and Electronic Engineering, Volume: 104, Issue: 14.
- Balanis, C. A.,(2005) *Antenna Theory - Analysis and Design*, 3rd Ed., New Jersey, USA, John Wiley & Sons, Inc., 2005.
- Buke, A., Hajian M., Ligthart L.P., Gardener P.,(1999) "Indoor channel measurements using polarisation diversity", Vehicular Technology Conference 1999, pp. 2282 - 2287 vol. 4, Sept. 19-22, 1999
- Chin-Lung Y.; Chappell, W.J. (2007); "Angular diversity – prominent for compact devices of wireless sensor network in indoor environments", Antennas and Propagation Society International Symposium, 2007 IEEE
- EURO-COST 231, (1991) European Cooperative in the Field of Science and Technical Research "Urban Transmission Loss Models for Mobile Radion in the 900 and 1800 MHz Bands," rev. 2, The Hauge.
- Goldsmith, A.(2005), *Wireless Communication*, Cambride, University Press, 2005.
- Gruden, M.; Westman, A.; Platbardis, J.; Hallbjorner, P.; Rydberg, A. (2009); "Reliability experiments for wireless sensor networks in train environment", Wireless Technology Conference, 2009. EuWIT 2009, Rome, Italy.
- Hata M., (1980)"Empirical Formula for Propagation Loss in Land Mobile Radio Services", IEEE Transactions on Vehicular Technology, Vol. VT-29, No. 3, August 1980, pp. 317-325.
- Jobs, M.; Gruden, M.; Hallbjörner, P.; Rydberg, A., (2010); "Antenna Diversity with Opportunistic Combining for ASK Systems with Single Channel Receivers", European Conference on Antennas and Propagation 2010, EuCAP2010, Barcelona, Spain.
- Jobs M.; Bestoon J.; Rydberg A.;(2009) "A Wireless Body Area Network (WBAN) Based Tracking and Monitoring Application System" The IET Conference on Body-centric wireless communications, Savoy Place, London, UK.
- Kita N., Ito T., Yokoyama S., Tseng M. C., Sagawa Y., Ogasawara M., and Nakatsugawa M., (2009), "Experimental Study of Propagation Characteristics for Wireless Communications in High-Speed Train Cars," 3rd European Conference on Antennas and Propagation (EuCAP2009), pp. 897-901.
- Miki, N.; Atarashi, H.; Sawahashi, M. (2004); "Effect of time diversity in hybrid ARQ considering space and path diversity for VSF-OFCDM downlink broadband wireless access", Personal, Indoor and Mobile Radio Communications, PIMRC 2004. 15th IEEE International Symposium on ,Volume: 1.
- Recommendation of ITU-R, (2007) "Propagation data and prediction methods for the planning of indoor radiocommunication systems and radio local area networks in the frequency range 900 MHz to 100 GHz," P.1238-5

- Simon, M.K., and Alouini, M.-S.;(2002), "A Unified Performance Analysis of Digital Communication with Dual Selective Combining Diversity over Correlated Rayleigh and Nakagami-m fading channels", *Communications, IEEE Transactions on*, Volume 47, Issue 1, Pages 33-43.
- Valenzuela-Valdes, J.F.; Garcia-Fernandez, M.A.; Martinez-Gonzalez, A.M.; Sanchez-Hernandez, D.A., (2009); "Evaluation of True Polarization Diversity for MIMO Systems", *Antennas and Propagation, IEEE Transactions on* Volume: 57 , Issue: 9, Page(s): 2746 - 2755.

IntechOpen

IntechOpen

IntechOpen

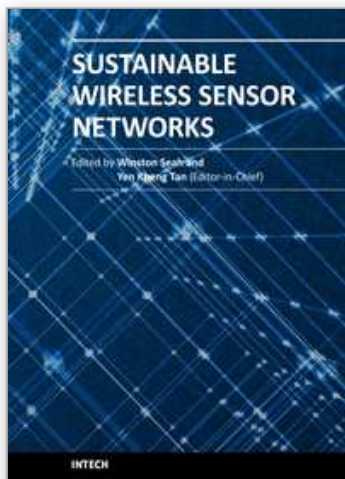

## **Sustainable Wireless Sensor Networks**

Edited by Yen Kheng Tan

ISBN 978-953-307-297-5

Hard cover, 574 pages

**Publisher** InTech

**Published online** 14, December, 2010

**Published in print edition** December, 2010

Wireless Sensor Networks came into prominence around the start of this millennium motivated by the omnipresent scenario of small-sized sensors with limited power deployed in large numbers over an area to monitor different phenomenon. The sole motivation of a large portion of research efforts has been to maximize the lifetime of the network, where network lifetime is typically measured from the instant of deployment to the point when one of the nodes has expended its limited power source and becomes in-operational – commonly referred as first node failure. Over the years, research has increasingly adopted ideas from wireless communications as well as embedded systems development in order to move this technology closer to realistic deployment scenarios. In such a rich research area as wireless sensor networks, it is difficult if not impossible to provide a comprehensive coverage of all relevant aspects. In this book, we hope to give the reader with a snapshot of some aspects of wireless sensor networks research that provides both a high level overview as well as detailed discussion on specific areas.

### **How to reference**

In order to correctly reference this scholarly work, feel free to copy and paste the following:

Mathias Grudén, Magnus Jobs and Anders Rydberg (2010). Diversity Techniques for Robustness and Power Awareness in Wireless Sensor Systems for Railroad Transport Applications, Sustainable Wireless Sensor Networks, Yen Kheng Tan (Ed.), ISBN: 978-953-307-297-5, InTech, Available from:

<http://www.intechopen.com/books/sustainable-wireless-sensor-networks/-diversity-techniques-for-robustness-and-power-awareness-in-wireless-sensor-systems-for-railroad-tra>

**INTECH**  
open science | open minds

### **InTech Europe**

University Campus STeP Ri  
Slavka Krautzeka 83/A  
51000 Rijeka, Croatia  
Phone: +385 (51) 770 447  
Fax: +385 (51) 686 166  
[www.intechopen.com](http://www.intechopen.com)

### **InTech China**

Unit 405, Office Block, Hotel Equatorial Shanghai  
No.65, Yan An Road (West), Shanghai, 200040, China  
中国上海市延安西路65号上海国际贵都大饭店办公楼405单元  
Phone: +86-21-62489820  
Fax: +86-21-62489821



© 2010 The Author(s). Licensee IntechOpen. This chapter is distributed under the terms of the [Creative Commons Attribution-NonCommercial-ShareAlike-3.0 License](#), which permits use, distribution and reproduction for non-commercial purposes, provided the original is properly cited and derivative works building on this content are distributed under the same license.

IntechOpen

IntechOpen